



- **Week #1**
- **(January 4 - 8)**
- **[Current Generation Networks: From 2G to 2.5G](#)**
- **Week #2**
- **(January 11-15)**
- **Value added Services in Current Generation Networks**
- **Week #3**
- **(January 18-22)**
- **Next Generation Network Vision**
- **Session Signaling and Signaling Protocol Specific Architecture**
- **Week #4**
- **(January 25 – 39)**
- **Web Services**
- **Project specification available**
- **Week #5**
- **(February 2 - 6)**
- **Tools for Value Added Services Engineering (SDS and Web Logic)**
- **Week #6**
- **(February 9 - 13) Quiz1**



Chapter II

Current Generation Networks: Value Added Services



Outline

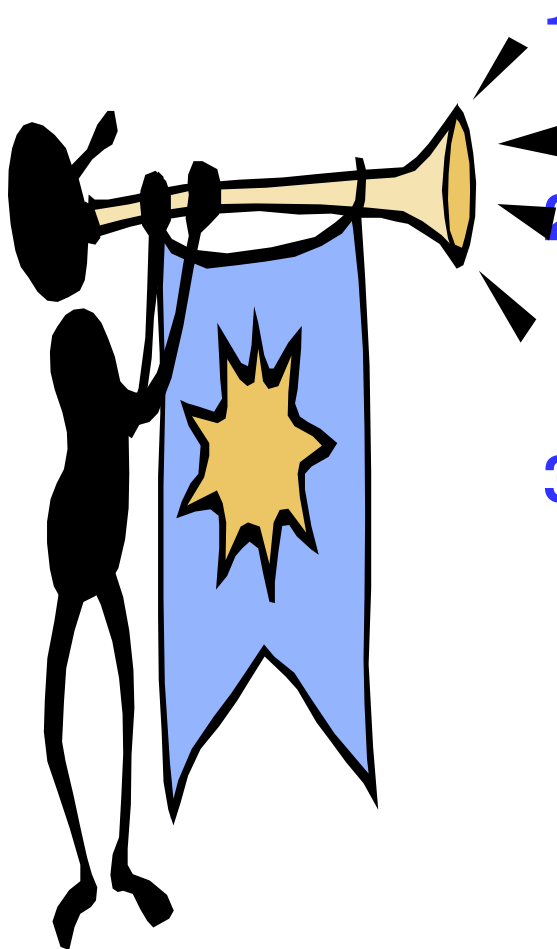

1. Fundamentals of service engineering
2. Telephony (or session oriented) services engineering
3. Non telephony (or non session oriented) services engineering



Fundamentals

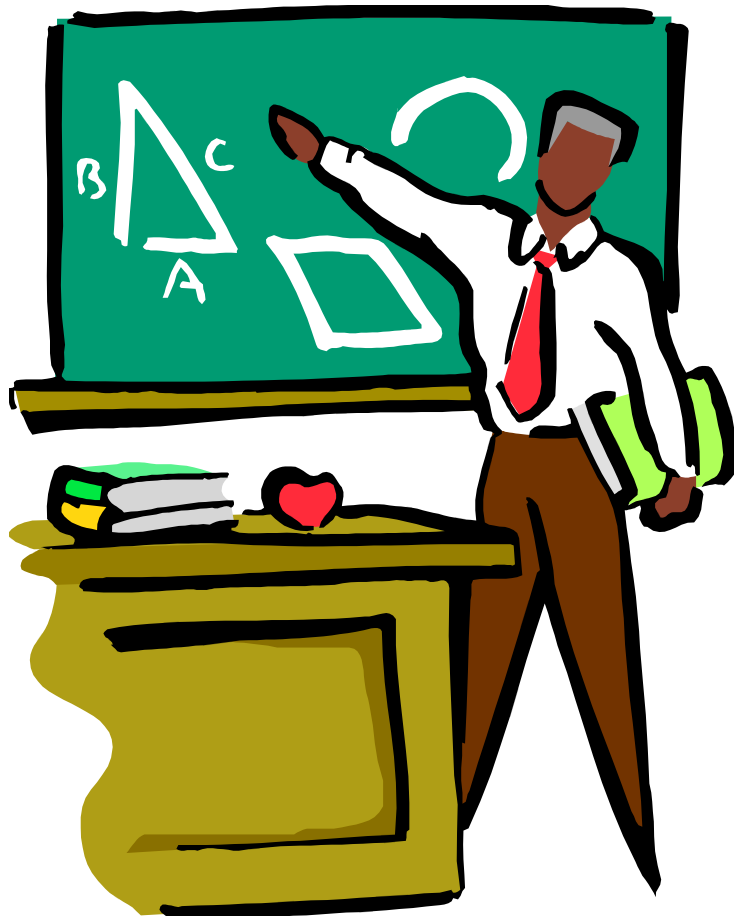

1. Services
2. Business model
3. Service engineering



Services

Basic service offered by circuit switched telephony:

Two party voice call

Value added services (or services for short)

Anything that goes beyond two party voice call



Services

- Telephony (or session oriented) services
 - interact with call control
 - Happen before, during or after a call
 - Some examples
 - Call transfer
 - Call diversion
 - Call hold
 - Call park and pick up
 - Call waiting
 - Message waiting indication
 - Name identification
 - Call completion
 - Call offer
 - Call intrusion



The examples

Call transfer

Allow a user A in communication with user B to establish a new call between user B and user C

- First case: User A has a call established with user C before the transfer
- Second case: User A does not establish any call with user C before the transfer

Call diversion

Divert the call (before answering it) if some conditions are met

- Unconditional
- Busy
- No reply



The examples

Call hold

Allow a user A to put user B on “hold” after the call has been established

- User B can hear music / advertisement in the meantime

Also allow user A to retrieve a call previously put on hold

Call park and pick up

Generalization of call hold / retrieve

- Parking places (I.e identifier for each parked call)
- Retrieval using identifiers



The examples

Call waiting

Allow a busy user to be notified of an incoming call and to decide how to proceed (Classical example; Internet call waiting)

- Accept (I.e give up on previous call)
- Reject
- Divert

Message waiting indication

Self explanatory

- User can call a message center



The examples

Name indication

Self explanatory ...

Call completion

Camp on

- Allow caller to establish a call with a busy callee as soon as callee is free and without having to re-dial callee's number.



The examples

Call offer ...

Strong form of call completion

Allow caller to offer a call to a busy callee and wait till busy callee accepts the call ...

Call intrusion

Allow user A to establish a call with a busy user B by breaking into the call between B and C

- Result: 3 party call



Services

- Non Telephony (or non session oriented) services
 - Do not interact at all with call control
 - Some examples
 - » Messaging (SMS)
 - » Internet access from a mobile phone



Services

- Hybrid services
 - Combination of telephony and non telephony services
 - Some examples
 - » Email notification of unsuccessful calls



Business model (Proposed by TINA consortium)

Roles

- **Consumer**
 - End-user: Actual user of the service
 - Subscriber: Entity having the business agreement for service usage
- **Retailer (or service provider)**
 - One stop shop
 - Entity which provides the services and which has the business agreement with the subscriber
 - Can provide own services or services subcontracted from third parties
- **Third party service provider**
 - Has business agreement with retailer and no direct business agreement with subscribers
- **Communication/connectivity provider:** “Pipe” provider
- **Broker:** Ensure fair information distribution to all parties

Business model (Proposed by TINA consortium)

Business roles / interfaces

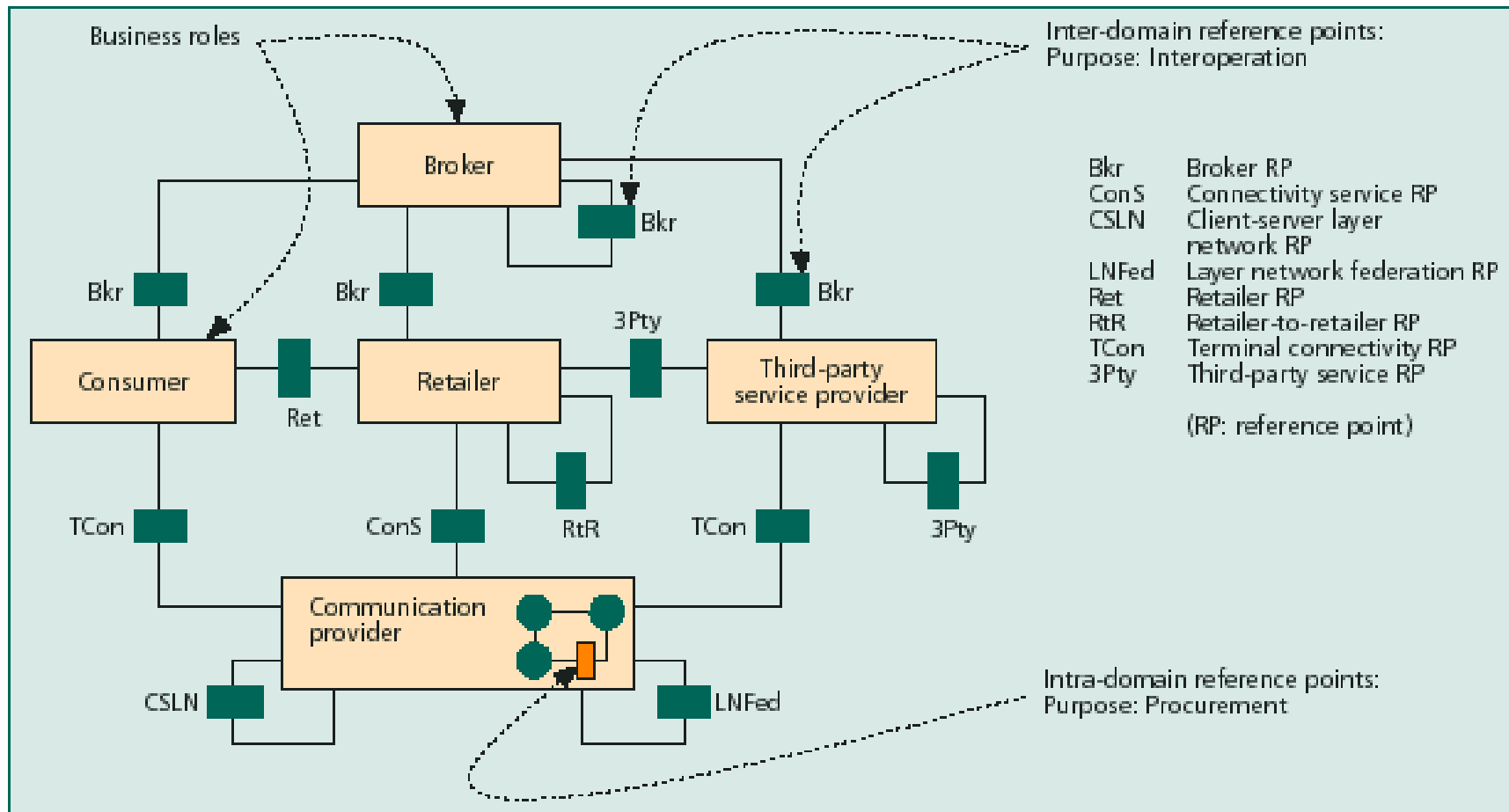

Note: Taken from IEEE Communications Surveys & Tutorials (Reference [x])



Service engineering (or service life cycle)

Four phases

- **Creation (also known as construction)**
 - Specification, design/coding, and testing
- **Deployment**
 - Service logic (or executable) resides on specific node(s) and needs to be deployed there
- **Usage**
 - Subscription/billing, triggering, features interactions
- **Withdrawal**
 - Removal from network



Service Engineering

Why is it an important discipline?

- **Business standpoint**
 - High quality two party voice call is now a commodity
 - Value added services are needed to attract subscribers and generate revenues.
- **Engineering standpoint**
 - It is less than trivial
 - Example: Service creation
 - Secure and selective access to network resources is required
 - Related issues: Level of abstraction, security framework, service creation tools ...etc.



Telephony services engineering

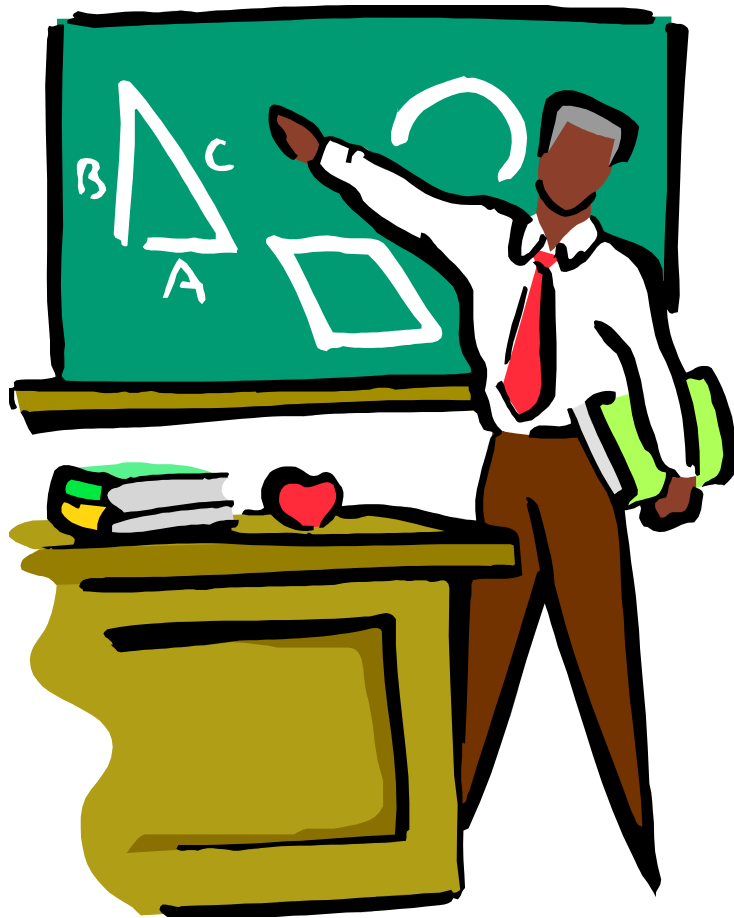

1. Supplementary service approach
2. Intelligent Network (IN)



Supplementary services approach

Fundamental principles

- Agreement and standardisation of the semantics of each and every supplementary service (i.e. what the service does from the end-user perspective)
- Agreement and standardization of how to enhance the signalling messages for implementing each and every supplementary service
- Enhancement of the software in each and every exchange for the realization of each and every supplementary service



An example of supplementary service engineering

Call diversion on busy

- User A calls user B
- User B is busy
- The call is diverted to user C who replies
- Signalling messages enhanced for its realization in the example
 - ACM (Address completion message)
 - Indication that B is busy
 - Number to which the call should be re-directed.



An example of supplementary service engineering

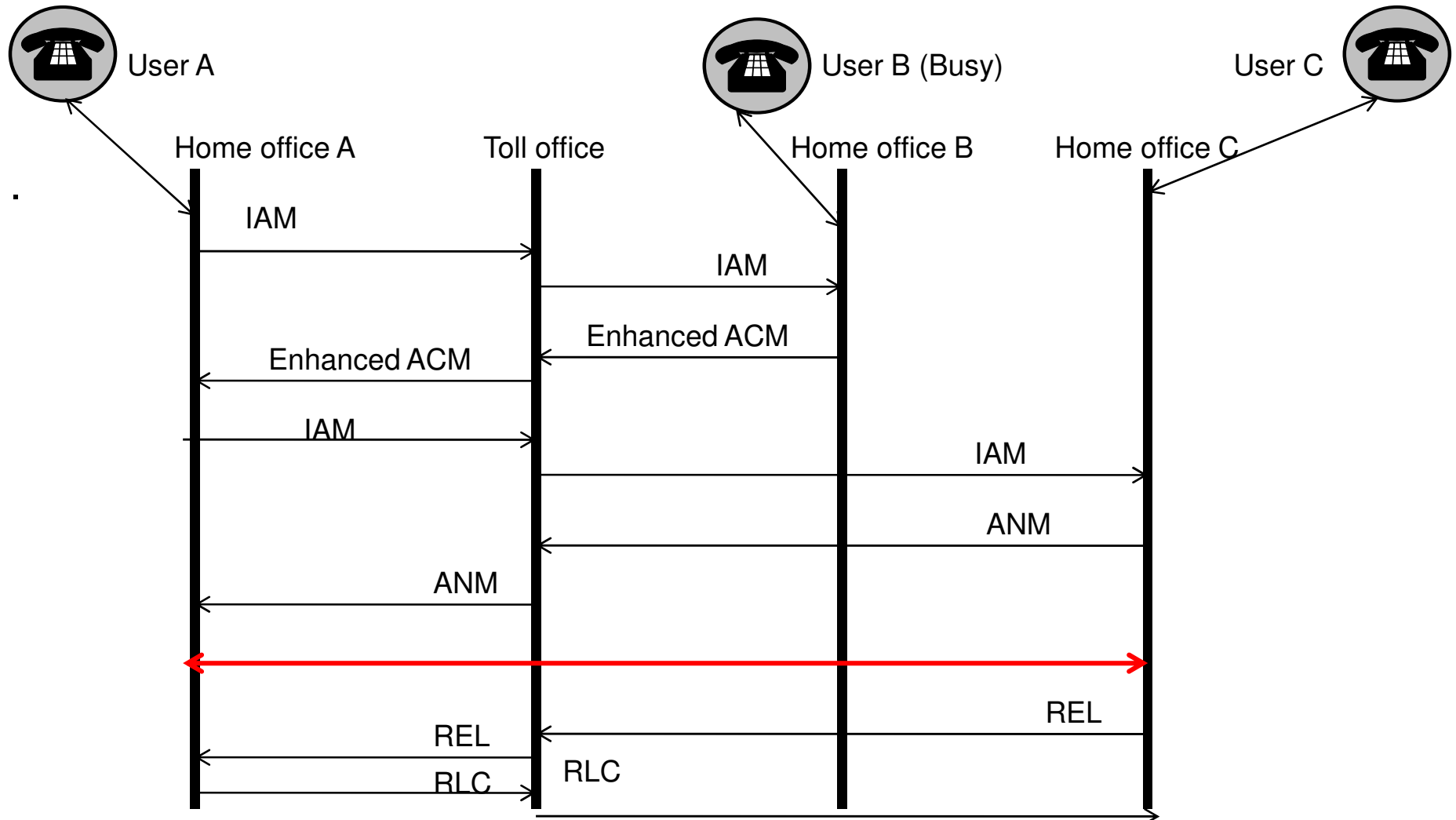



Introduction to IN

The pre-IN era

- Service logic embedded in switching software (supplementary service approach)

IN

- Has emerged in the ITU-T based on work done at Telcordia (alias Bellcore), in the late 80s
- Basis for:
 - AIN (North America - fixed network)
 - Wireless Intelligent Networks (WIN) - (D-AMPS - wireless network)
 - Customized Application Mobile Enhanced Logic (GSM - wireless network)



IN: Fundamental Principles

1. Separation of switching software and service logic

Main implication: Need for an interaction model between switching and service

- Functional entities / nodes
- Protocols

2. Standardization of capabilities for building services

Main implication: Need for “components” that can be used in various ways for building services



IN: Fundamental Concepts

Call model

Phases for setting up and tearing down calls

- **IN call model or basic call process: call model with the possibility to invoke service**
 - » **Point of invocation**
 - » **Point of return**

Service independent building blocks (SIB)

Components used to build services

- Have a logical start and one or more logical ends
- Are chained to build services

Capabilities set

- A set of potential services
- A given call model
- A set of SIBs
- A set of functional entities
- A protocol



IN: A four planes conceptual architecture

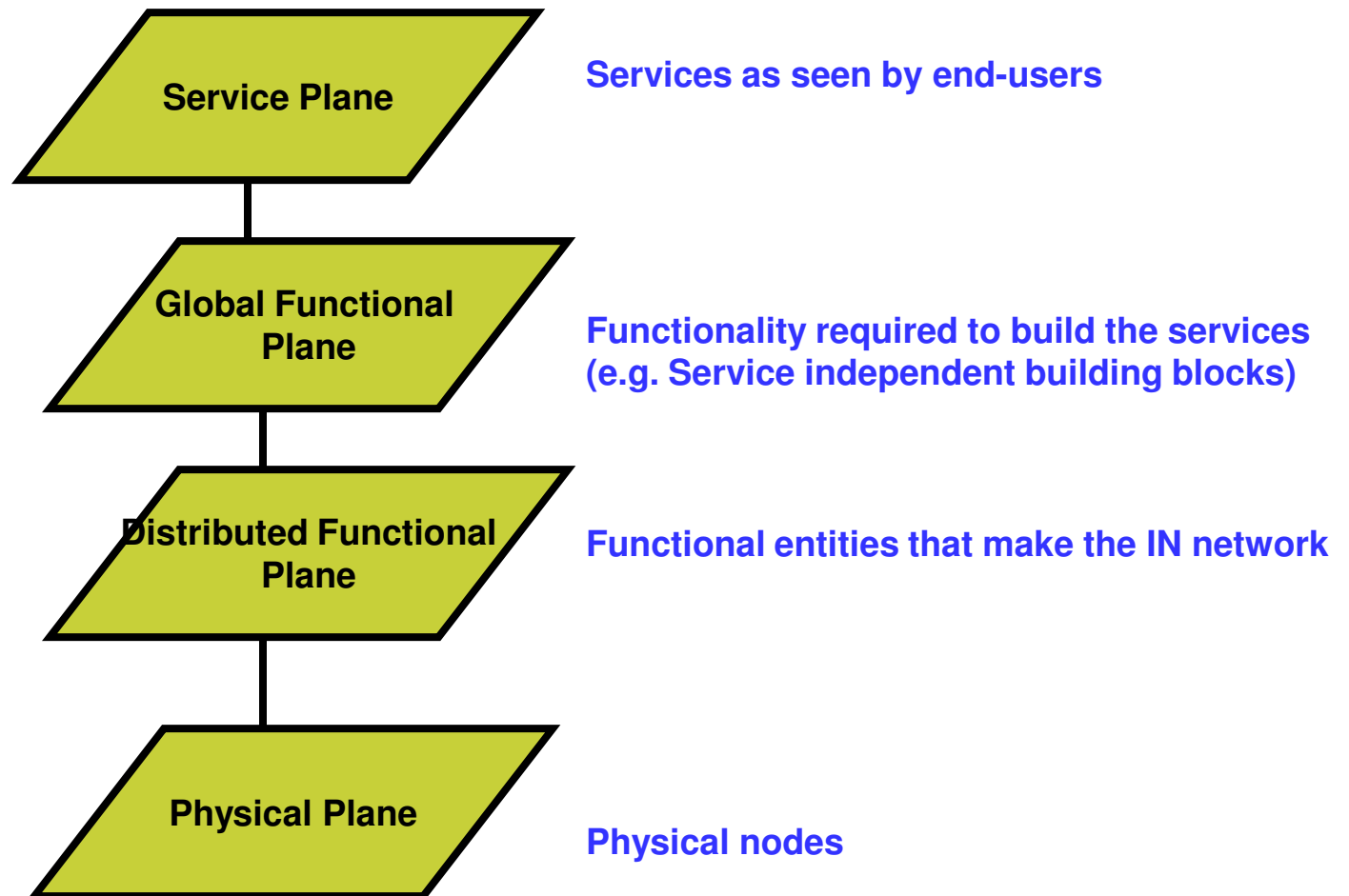



IN: Service Plane

Examples of services made of specific features

Free phone

- One number (800 in North America) feature
- Reverse charging feature

Calling card

- Charging feature
- Originating user prompting



IN: Global Functional Plane

...Simplified Free phone

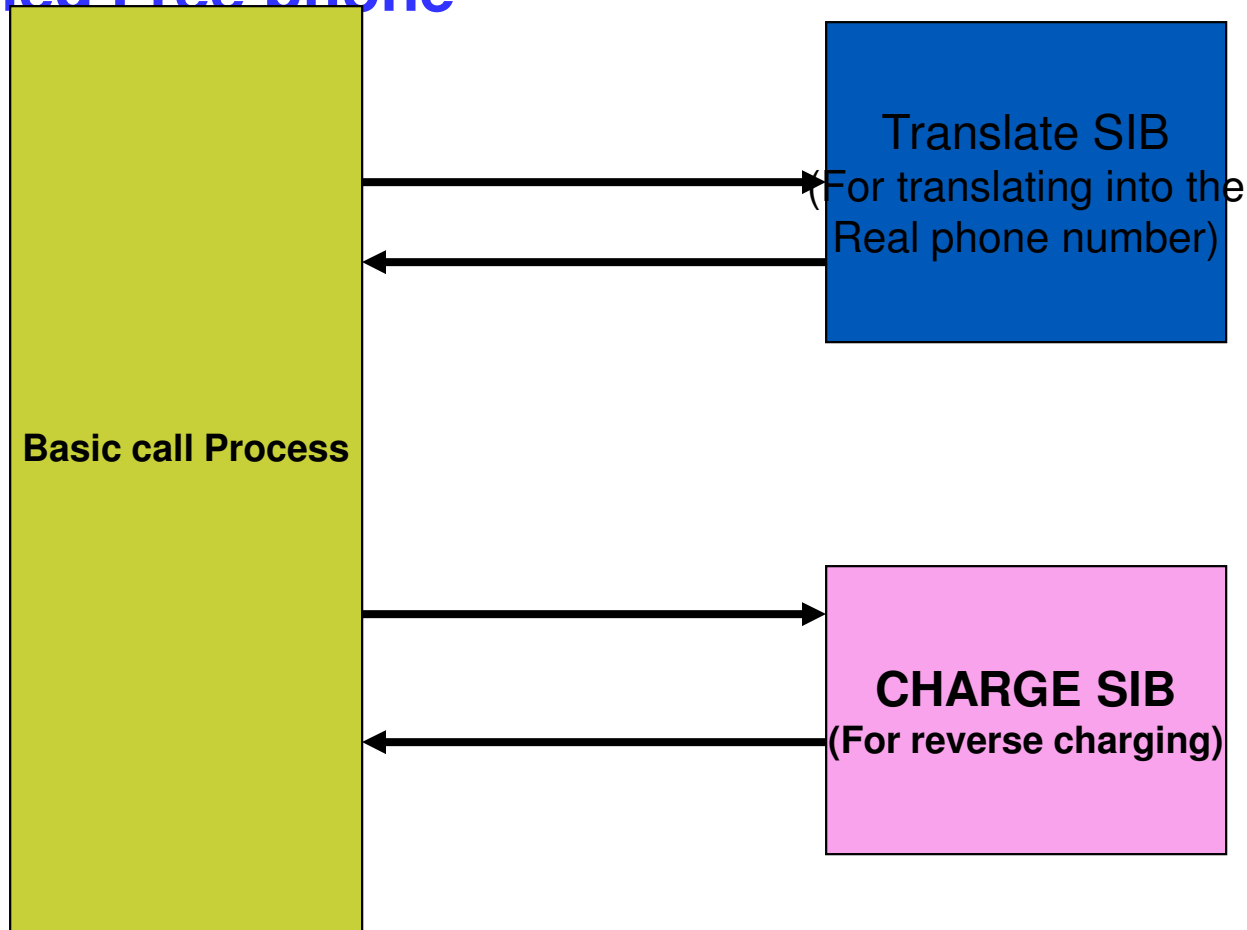



IN: Physical Plane

Functional entities can be grouped in nodes as manufacturers wish

The Intelligent Network Application Protocol (INAP) is used for communications between nodes.

- Request / Reply application level protocol
- Messages transported over SS7
- SS7
 - Overlay packet switched networks
 - Used for outband signalling
 - Made of
 - Message transport part
 - Application part



IN: Physical plane

An example of physical implementation ...

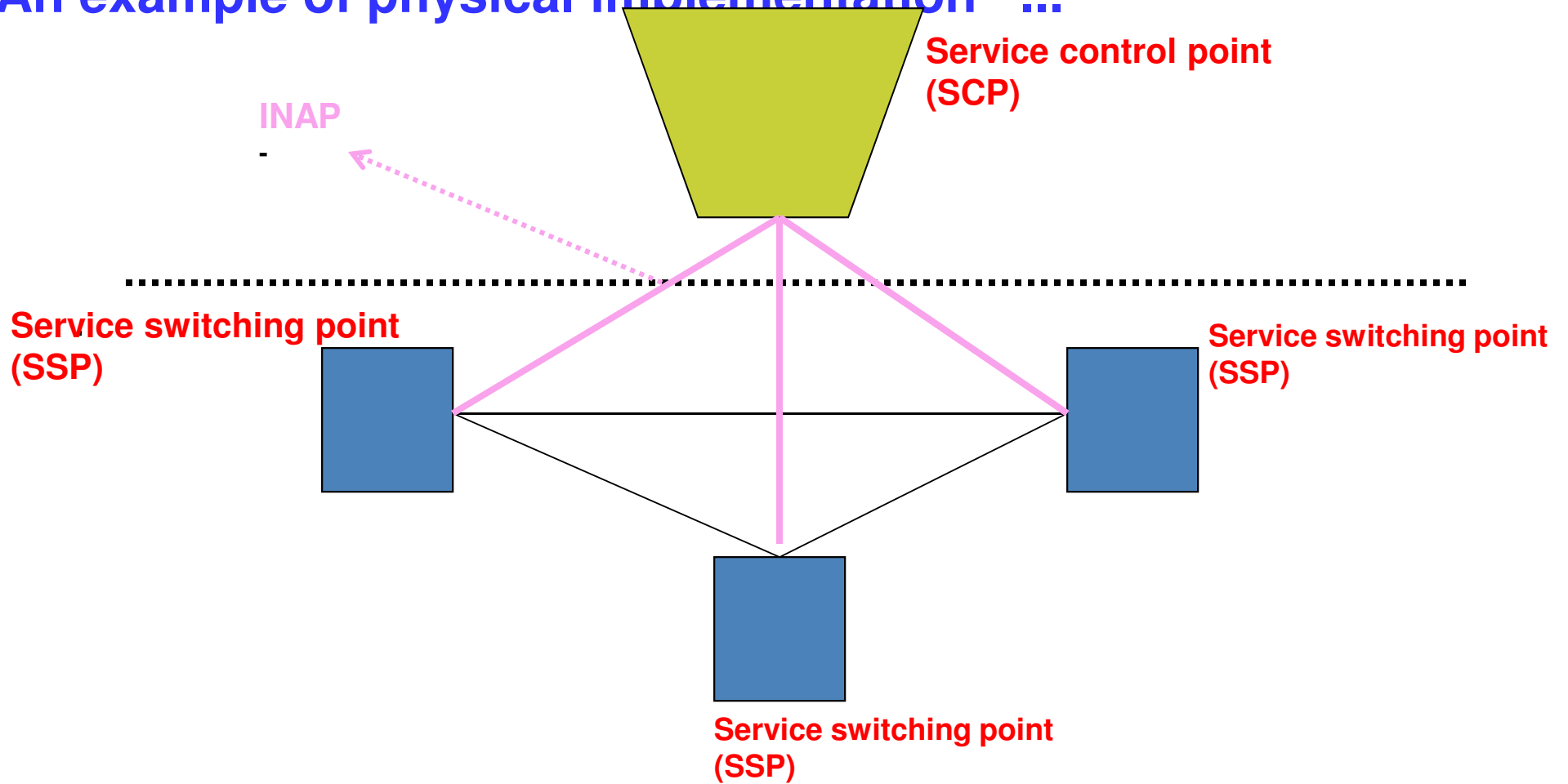



IN: Retrospective

A revolutionary concept

- Separation between service logic and switching software
- Standardisation of service capabilities instead of services

With mixed results

- Reasonable installed basis, but
- Lack of openness
 - Standardised building blocks (e.g. SIBs) did not open telecommunication networks to third parties
 - Components are not interfaces
 - Too many “proprietary” SIBs
- Service creation and deployment remain relatively slow
 - Immaturity of methodologies and tools
 - New service logic in SCPs often required “adjustments” to call model in SSP



Non telephony services engineering

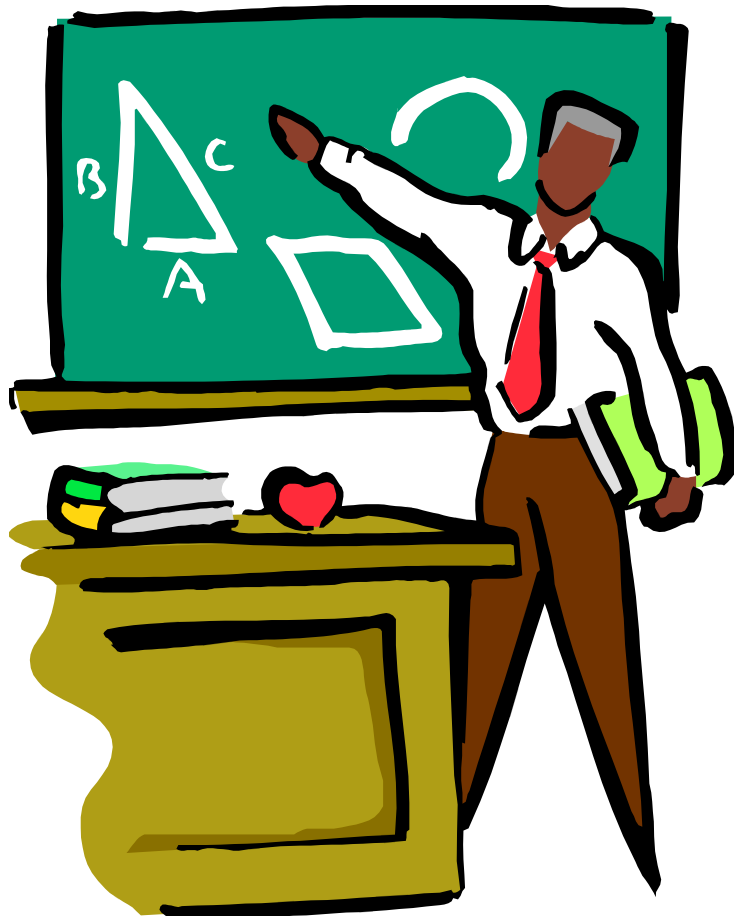

1. Short Message Service (SMS)
2. WAP for Wireless Internet Access



Short Message Service (SMS)

Most widely used value added service in current generation networks

- Initially (early 90s) engineered to re-use spare capacity in SS7 networks, but now a key revenue generator for operators
 - Consumer applications (e.g. person to person messaging, ring tone downloading, restaurants suggestions based on handset location)
 - Corporate / business applications (e.g. SMS integration with Outlook, bus tracking)
 - Cellular operator applications (remote upgrading of data stored on a SIM card)



Short Message Service (SMS)

Business model

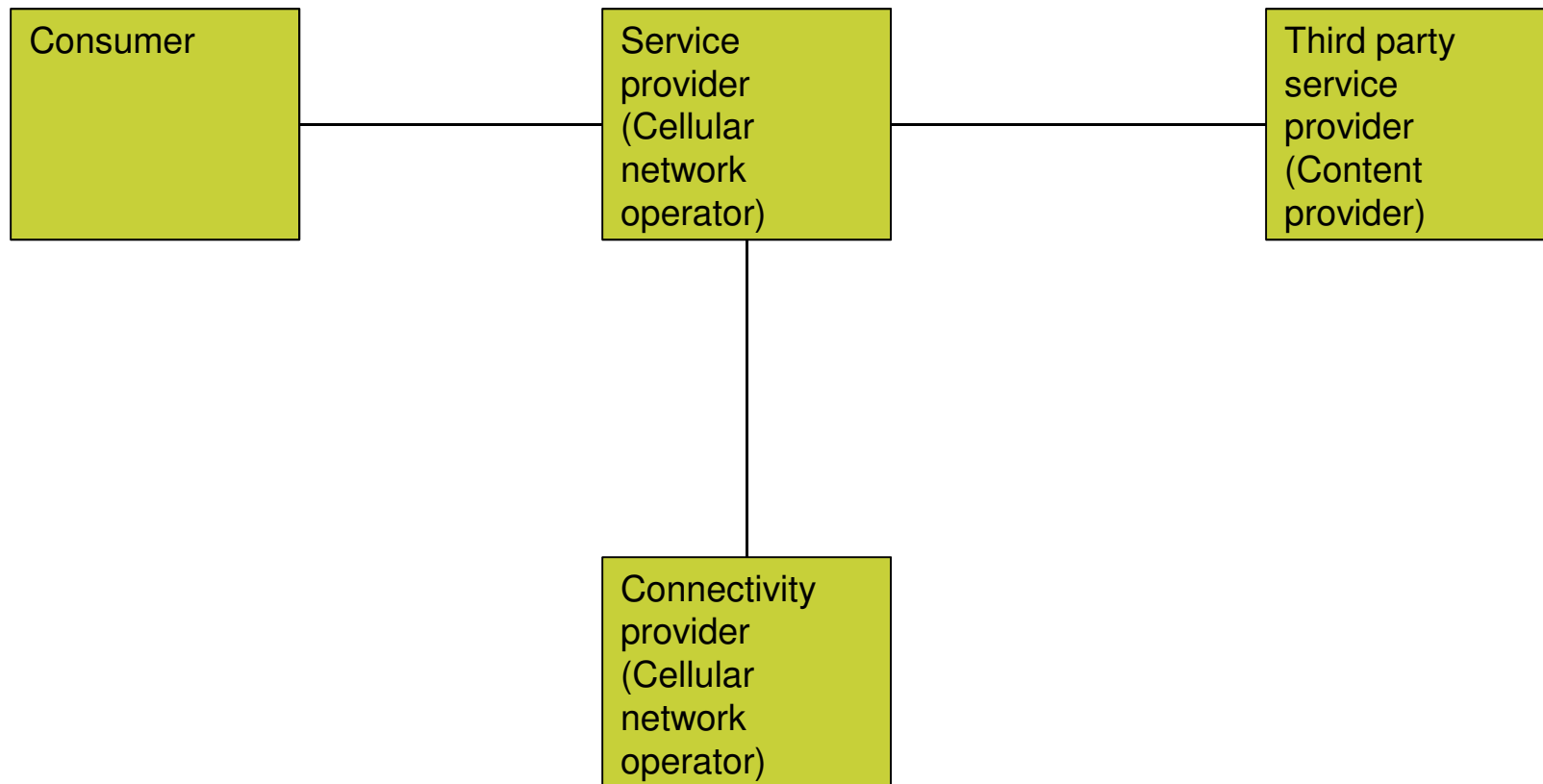



Short Message Service (SMS)

The functional entities

- SMS entity (SME)
 - Internal source or sink of short messages (i.e. within the cellular network)
 - Mobile stations (MS)
 - Reachable via the subscriber number
- External SMS entity (ESME)
 - External source or sink of short messages (i.e. outside the cellular network)
 - Examples: Email/SMS gateway, content provider servers (e.g. list of movies, ringtones. weather)
 - Reachable via a short code
 - Example 466453 (GOOGLE)
 - A wide range of services (e.g. weather, sushi, sports)
 - <http://www.google.ca/mobile/sms/index.html>



Short Message Service (SMS)

The functional entities

- SMSC
 - SMS switch (Store and forward or forward and forget)
 - Store and forward
 - Resends for some period till message successfully received
 - Forward and forget
 - No retransmission attempt
- SMS-GMSC / SMS - IWMSC
 - Interworking between SMSC and MSC
 - May be collocated/integrated with SMSC or MSC
 - Mobile station (MS) originating message
 - Mobile station (MS) terminating message



Short Message Service (SMS)

Functional entities

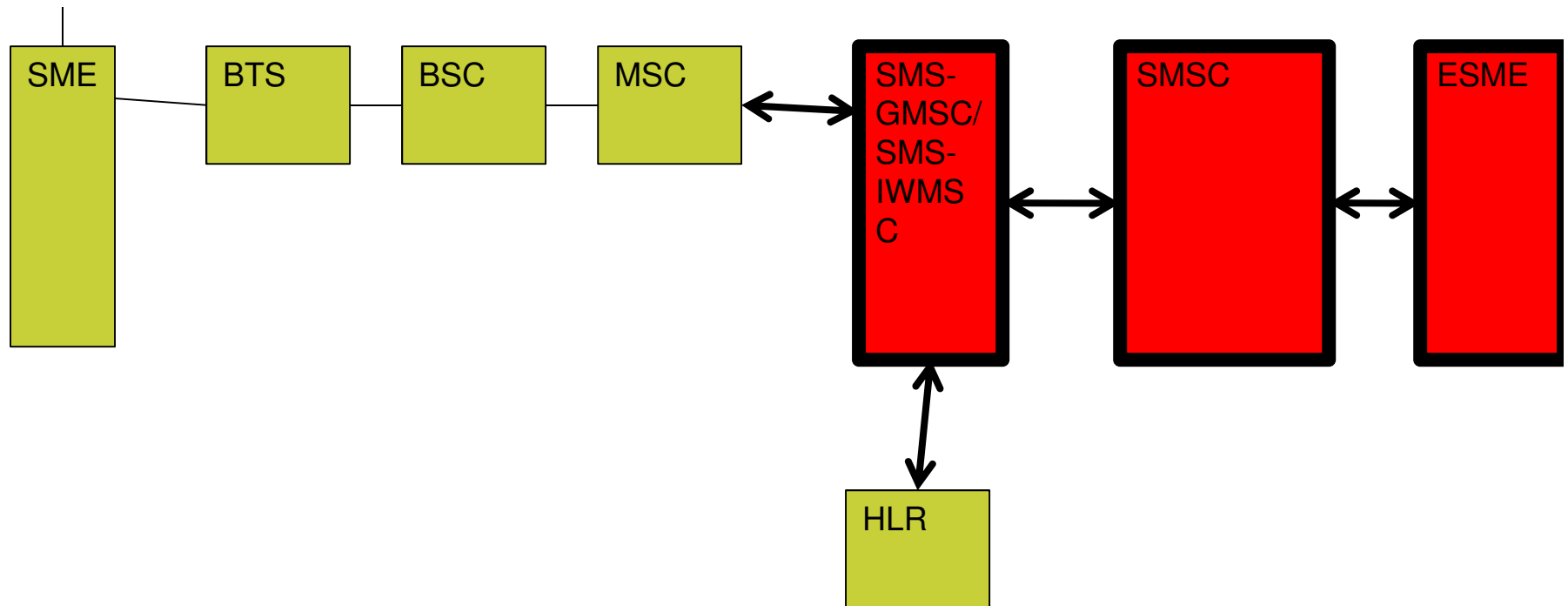



Short Message Service (SMS)

The interfaces

- Short Message Peer to Peer (SMPP) protocol
 - ESME and SMSC
 - SMSC and SMSC (when messages are routed without using the cellular network infrastructure)
 - Internet flavored open and standard application layer protocol
 - runs on top of IP and Internet Transport protocols such as TCP
 - Why?
 - ESMEs are generally external servers that support TCP/IP instead of SS7 stack



Short Message Service (SMS)

The interfaces

- Short Message Peer to Peer (SMPP) protocol

Key features

- Request / reply session based protocol (i.e. need to establish sessions before sending requests)
 - Three types of sessions initiated by ESME
 - Transmitter session (TX)
 - ESME can send messages to SMSC that will send them to mobile stations (i.e. mobile terminated messages)
 - Receiver session (RX)
 - ESME can receive messages from SMSC (i.e. mobile originated messages)
 - Transceiver session (TRX)
 - ESME can transmit and receive (i.e both mobile originated and mobile terminated messages)
 - SMSC can also initiate sessions with ESME (i.i outbind session)



Short Message Service (SMS)

The interfaces

- Short Message Peer to Peer (SMPP) protocol

The operations

- Session management
- Message submission
- Message delivery
- Message broadcast
- Ancillary operations (e.g. enhanced features such as message cancelation, queries, message replacement)



Short Message Service (SMS)

The interfaces

- Short Message Peer to Peer (SMPP) protocol

Examples of messages

- Session management
 - bind_transmitter
 - bind_Receiver
 - Bind_transceiver
- Message submission
 - Submit_sms
- Message delivery
 - Deliver_sms
- Message broadcast
 - Broadcast_sm
- Ancillary operations (e.g. enhanced features such as message cancelation, queries, message replacement)
 - Cancel_sm



Short Message Service (SMS)

A call case

- Assumption (SMS-GMSC / SMS-IWMSC is collocated with SMSC)

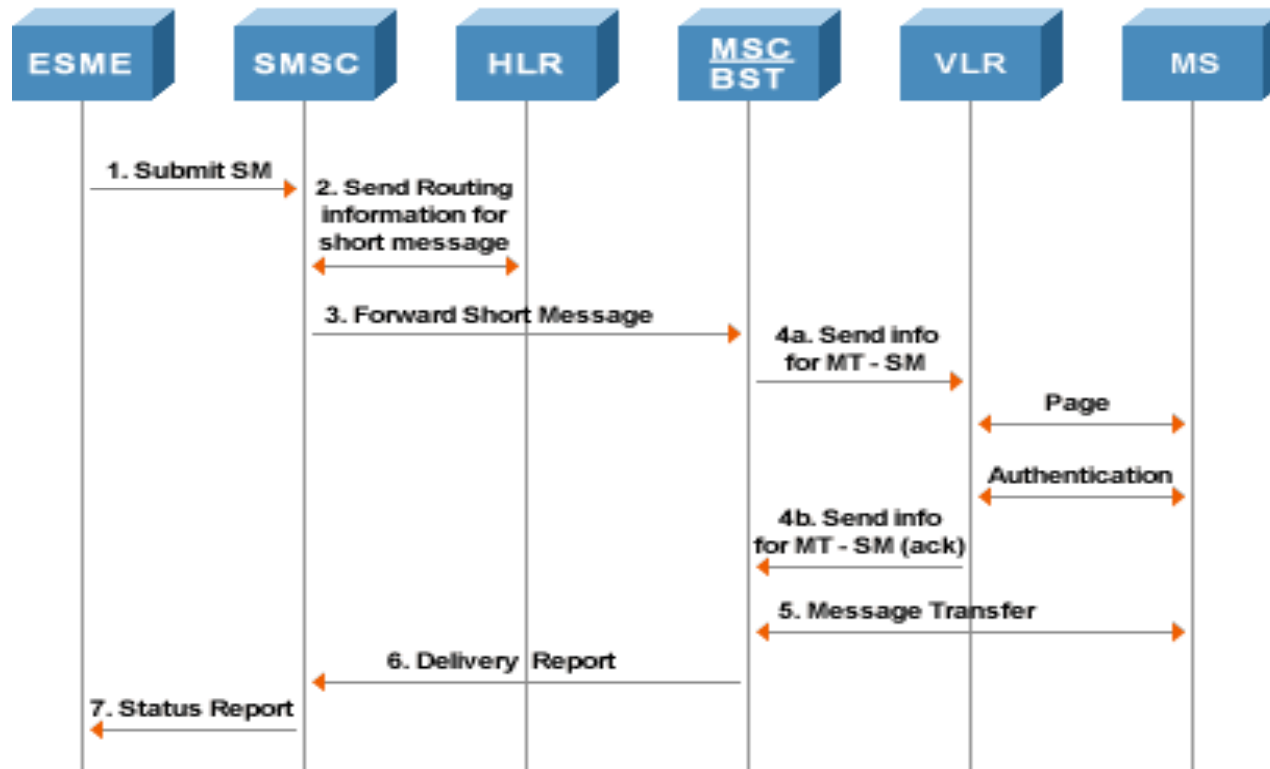



WAP: Introduction

Product of an industry consortium, the WAP forum

- First release 1998 (WAP 1.0)
- Second release 2002 (WAP 2.0)
- Now transferred to the the Open Mobile Alliance (OMA)

Main objective: bring non telephony services to wireless users ...

- Web browsing
- Email

Raison d'etre

- Limitations of cellular phones(Power, memory, battery)
- Limitations of today's wireless networks (Scarce bandwidth, unreliable links)



WAP: Fundamental principles

Optimal usage of “scarce” air interface resources

- Implications
 - Less bandwidth hungry protocols
 - binary encoding instead of text encoding

Optimal usage of “limited” terminal capabilities

- Implications
 - New description language(s)
 - New browser(s)

Independence of underlying bearer (e.g. GSM, TDMA, PDC)



Fundamental concepts

WAP Micro browser

- Browser adapted to limited terminal capabilities

WAP proxy/gateway

- Gateway between the Internet and operator's domain
 - Protocol gateway
 - Content adaptation
 - New description language(s)
 - New browser(s)

Application framework

- Application development / execution environment
 - APIs
 - Mark ups
 - Scripting



WAP: Basic Architecture

Protocol stacks (Legacy WAP 1.x stack + WAP 2.0 Internet protocol stack) ...

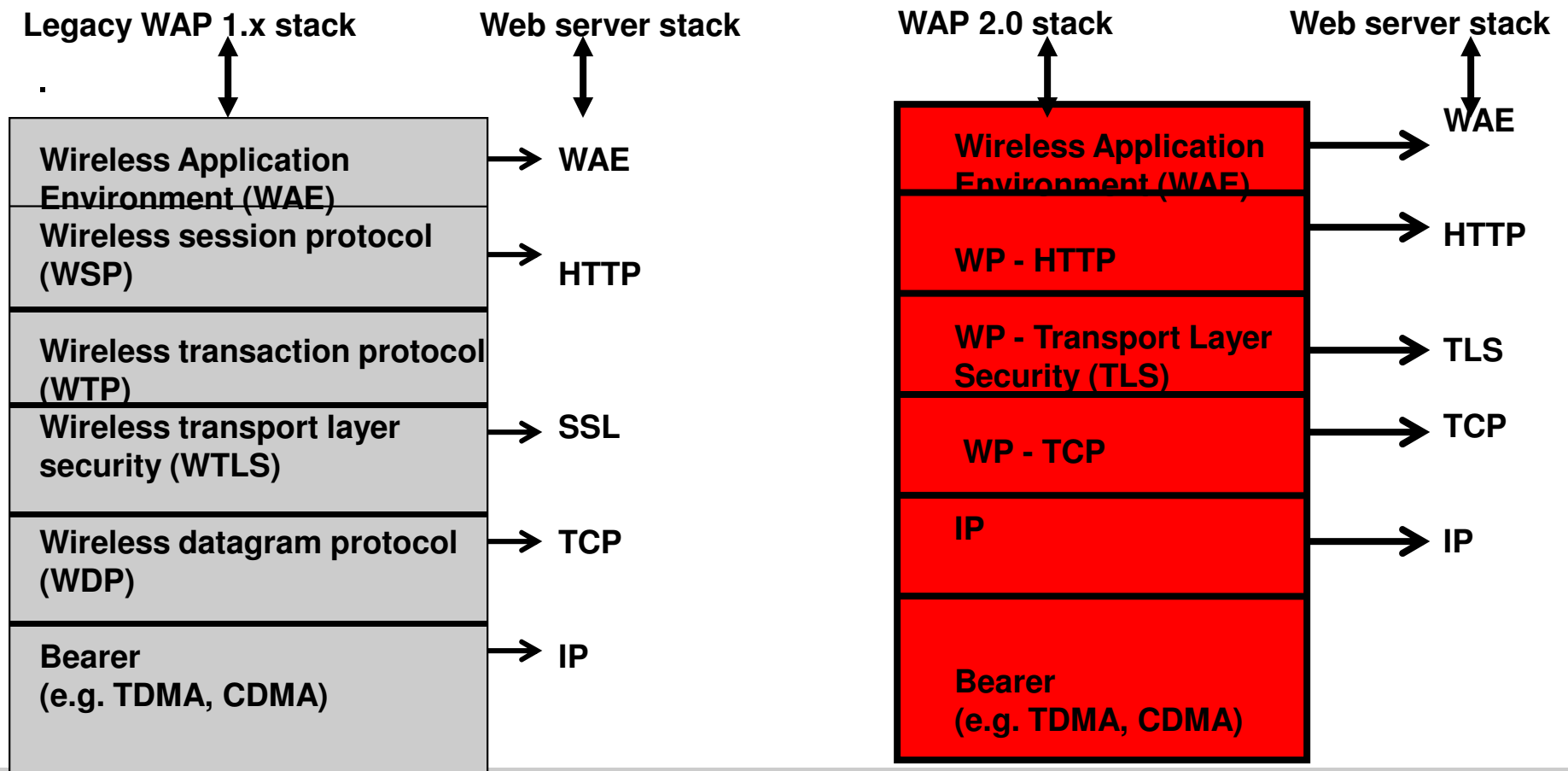



WAP: Basic Architecture

Network view

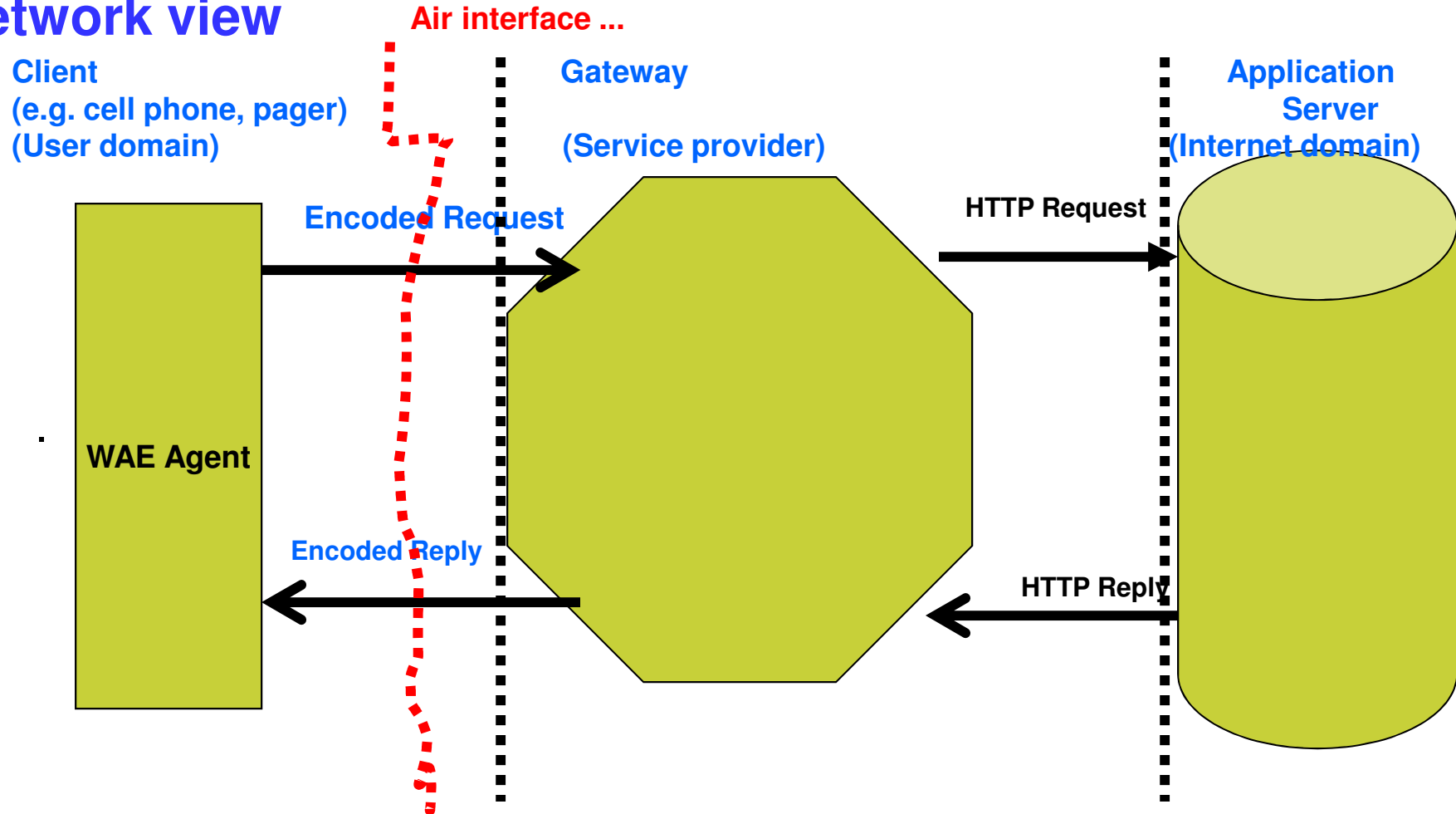



WAP: Beyond Internet wireless access ...

Push

- Information pushed to wireless device instead of the classical Internet pull model
 - Notifications (e.g. voice messages waiting to be retrieved)
 - News, traffic information

Wireless Telephony Applications

- Enhancements to call control services
 - Call initiation using an electronic agenda
 - On-line selection of how to handle a call (accept, reject, forward)

Multimedia messaging

- Interface between the client and the messaging server



WAP: Simplified Push

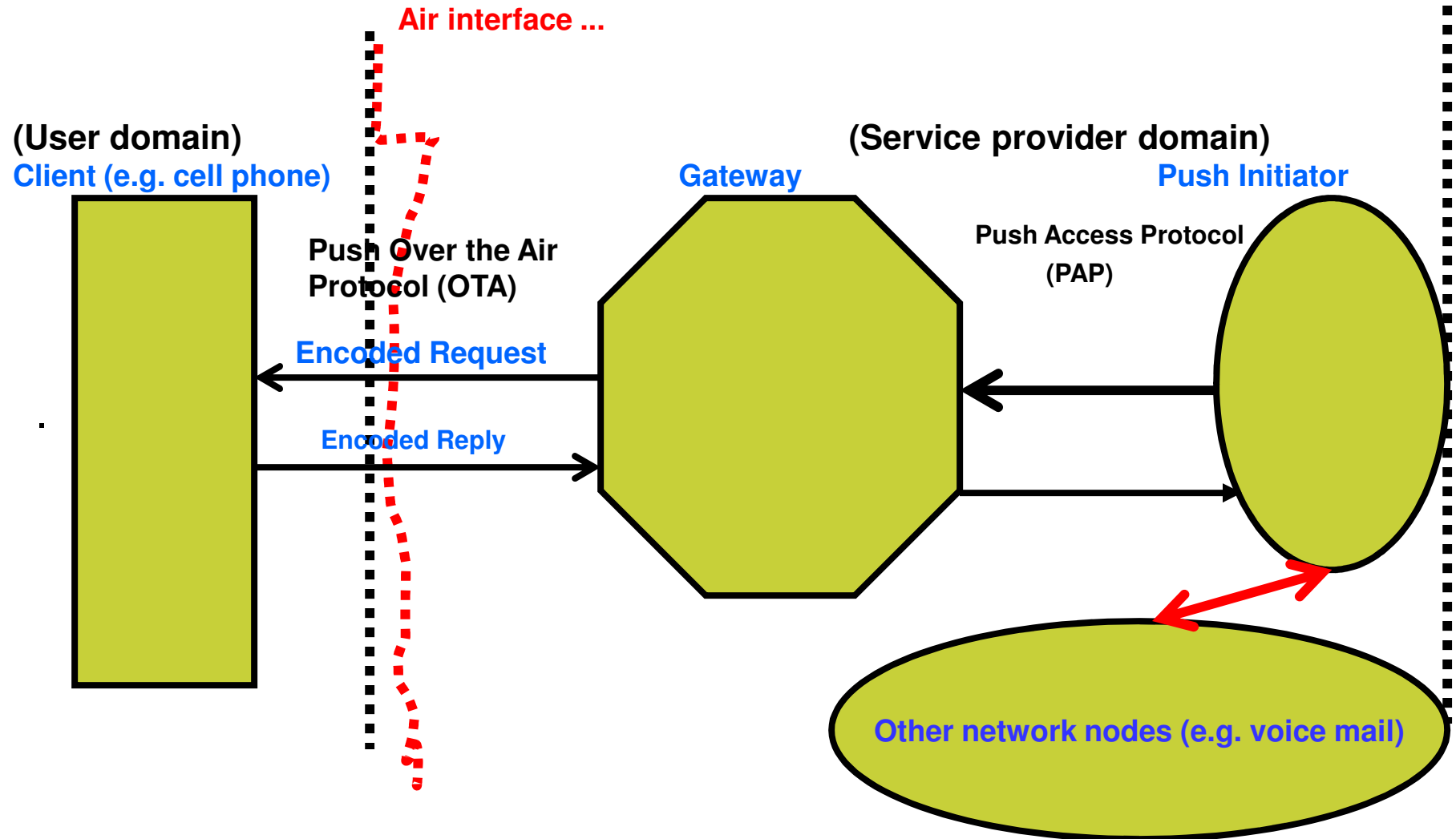



WAP: Simplified WTA

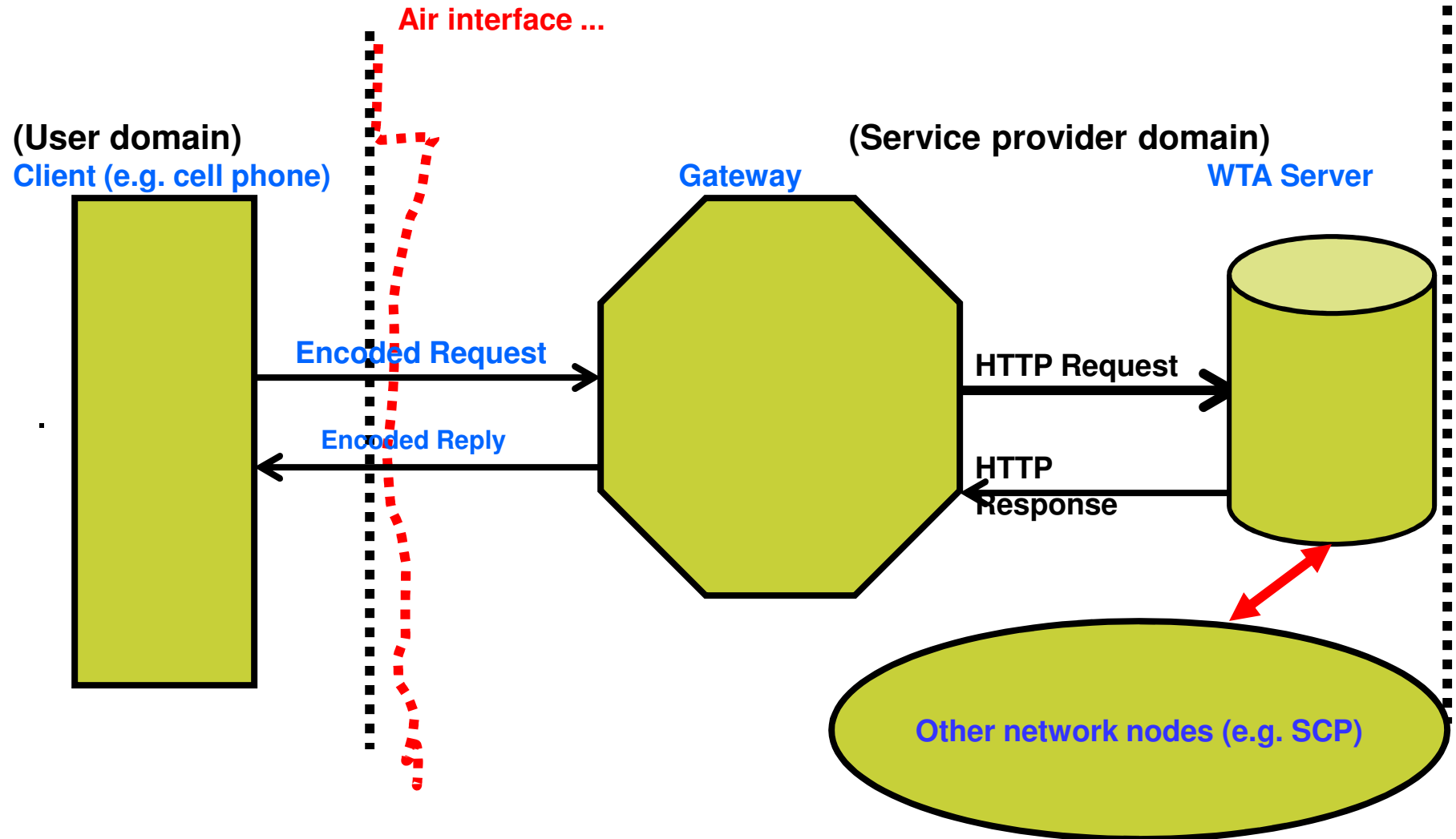



To probe further ...

On business model

H. Berndt, T. Hamada, and, P. Graubmann TINA: Its Achievements and its Future Directions, IEEE Communication & Surveys, 1Q 2000,

On intelligent networks

R. Glitho and Th. Magedanz, guest editors, Intelligent Networks in the new Millennium, IEEE Communications Magazine, June 2000 Vol.38 No6

On SMS

G. Peersman and S. Cvetkovic, The Global System for Mobile Communications Short Message Service, IEEE Personal Communications, June 2000

J. Brwon, B. Shipman and R. Vetter, SMS: The Short Message Service, IEEE Computer, December 2007

SMPP v.5:<http://www.hs1sms.com/documents/SMPPV5.pdf>

On WAP

WAP 2.0 Technical white paper, <http://www.wapforum.org>