

## Link Budget

---

In previous lectures, we discussed the relationship between the Bit Error Rate (BER) and the received  $\frac{E_b}{N_0} = \frac{W}{R_b} \cdot \frac{P_r}{N}$  where  $\frac{P_r}{N}$  is the ratio of the received signal power to the noise power.

We now try to find  $\frac{P_r}{N}$  for a given link consisting of the elements shown in the slide shown on slide 4. What we will do is first to multiply the transmitter power by all the gains such as amplification, antenna gain, etc. and then divide the result by all different attenuations in order to find the power at the receiver ( $P_r$ ). Then we add all sources of noise in order to come up with the noise power N. Finally, we divide  $P_r$  by N to get  $\frac{P_r}{N}$ . Of course when the quantities are in dB the multiplication and division are replaced by addition and subtraction. This procedure is called **Link Budget** calculation and is quite straightforward and can be done using an spreadsheet program. There are a lot of free software doing this. In fact almost any satellite service provider or equipment manufacturer for terrestrial and satellite systems has one on its website.

# Lecture 7: Link Budget

The first thing to consider is the transmit power  $P_t$ . This is the power at the output of HPA. This is the power delivered to the transmit antenna. The electromagnetic field leaving the antenna spreads radially and at a distance the power density is  $\frac{P_t}{4\pi d^2}$  where  $4\pi d^2$  is the surface area of a sphere centered at the transmitter and radius  $d$ .

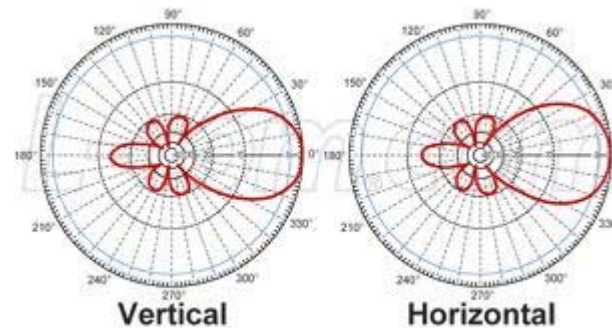
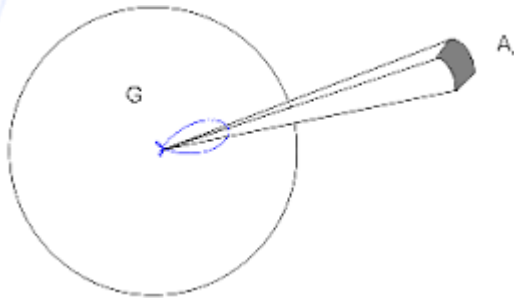

This formula is only valid if the electromagnetic wave travels at all directions, i.e., when the antenna is isotropic. Usually antennas are directive, that is, the radiation is more concentrated in a certain direction. The gain of the antenna is the ratio of the total volume of the sphere to that of the solid angle. The power density of a system using a transmit antenna with gain  $G_T$  is  $\frac{P_t G_T}{4\pi d^2}$ .

# Link Budget

---

The received power  $P_r$  is proportional to the effective area of the receive antenna.  
So,

$$P_r = \frac{P_t G_t}{4\pi d^2} A_{e,r}$$

The relationship between the gain and the effective area of an antenna (also called antenna aperture) is:

$$G = \frac{4\pi A_e}{\lambda^2}$$

where  $\lambda = \frac{c}{f}$

Is the wavelength of the transmitter signal.

So the effective area of the receive antenna is,

$$A_{e,r} = \frac{\lambda^2}{4\pi} G_r.$$

Substituting this in the formula for the received power, we get,

$$P_r = \frac{P_t G_t G_r}{\left(\frac{4\pi d}{\lambda}\right)^2} = \frac{P_t G_t G_r}{L_s}$$

## Link Budget

---

where  $L_s$  is called space loss or path loss and represents the effect of the distance between the transmit and receive antennas. If there are other losses such as those in cables and connectors, we lump them together and denote them  $L_o$  for other losses. So,

$$P_r = \frac{P_t G_t G_r}{L_s L_o}$$

Changing the received power into dBW (dB Watt), we have,

$$P_r = P_t + G_t + G_r - L_s.$$

Where  $P_t$  and  $P_r$  are in dBW or dBm (dB mW),  $G_t$  and  $G_r$  are in dBi (dB compared to an isotropic antenna) and  $L_s$  and  $L_o$  are in dB.

$$L_s = 10 \log \left( \frac{4\pi d}{\lambda} \right)^2.$$

Note: Decibel (dB) takes the unit of the quantity it is applied to so if power is in Watts, we have dBW, if it is in mW then its decibel value is in dBm. Take 100 Watts of power. It is 20 dBW. But since it is 100,000 mW, it is 50 dBm. The value in dBm is 30 dB higher than the dBW value. Dimensionless entities such as gain are just in dB. One  $P_r$  is found, we can find  $E_b = \frac{P_r}{R_b}$ .

---

## Link Budget

---

**Example:** A transmitter transmits with 50 W power at a frequency of 10 GHz. to a satellite at a satellite at a Geostationary orbit (at an altitude of 36000 km.). Find the received power at the satellite if the Earth station antenna has a diameter of 2 m. and efficiency of  $\eta = 0.65$ . Assume that the receive antenna at the satellite has a gain of 45 dBi.

**Solution:** The gain of the transmit antenna is,

$$G_t = \frac{4\pi}{\lambda^2} A_{e,t}$$

where  $\lambda = \frac{c}{f} = \frac{3 \times 10^8}{10 \times 10^9} = 0.03$  m. and  $A_{e,t} = \left(\frac{D}{2}\right)^2 \pi \eta = \left(\frac{2}{2}\right)^2 \pi \times 0.65 = 2.04$ .

So,  $G_t = \frac{4\pi}{(0.03)^2} \times 2.04 = 28,484$  or 44.55 dBi.

$P_t = 10 \log(50) \approx 17 \text{ dBW} = 47 \text{ dBm}$ .

$L_s = 10 \log \left( \frac{4\pi \times 36 \times 10^6}{0.03} \right)^2 = 203.57 \text{ dB}$ .

Therefore,

$$P_r = 47 + 44.55 + 45 - 203.57 \approx -67 \text{ dBm or } -97 \text{ dBW}.$$

# Link Budget

We have talked about how to find the power at the receiver  $P_r$  and, therefore,  $E_b$ . Now, let's find  $N_0$ . The noise generated by a circuit with resistance  $R$  at a temperature  $T$  and bandwidth  $W$  is given by  $4k_BTRW$  where  $k_B = 1.38 \times 10^{-23}$  is called the Boltzmann constant. This is called the thermal noise. It has a flat spectral density over the frequency band and is distributed according to Gaussian distribution. That is why it is called Additive White Gaussian Noise (AWGN).

Modelling the noise source with a voltage source  $\sqrt{4k_BTRW}$  and a resistor  $T$ , we find the maximum power that it can deliver to a load is  $N = k_BTW$ . This happens when the load has a resistance equal to  $R$ .

Dividing  $N$  by  $W$ , we get the noise density  $N_0 = k_B T$ .  $T$  is called the noise temperature.

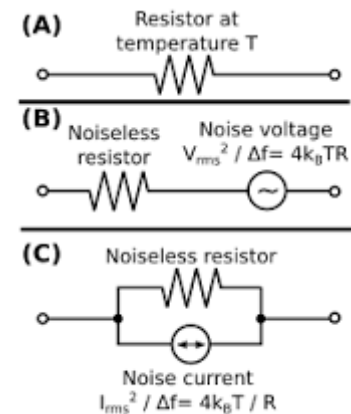

# Link Budget

Communication links such as a broadcasting system consists of different equipment in cascade. For example, a home TV reception system has an antenna connected to LNB, down converter, then to the coaxial cable, the power amplifier, the receiver, etc. Each of these components can be modeled with a gain (or a loss that can be considered as a gain of less than unity).

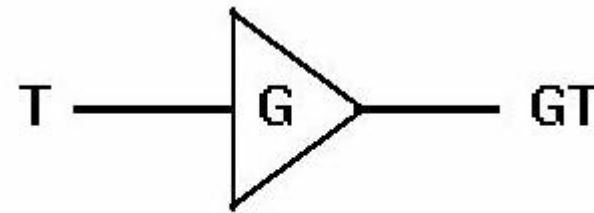

Figure 1. An ideal noiseless amplifier.

It would not be realistic to assume any component to be noise free. The model with noise included is,

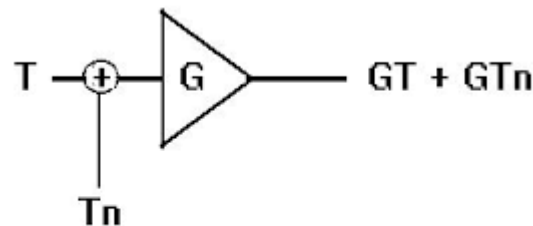

Figure 2. An amplifier with noise temperature  $T_n$ .

## Link Budget

Now, assume that two components with Gains  $G_1$  and  $G_2$  and noise temperatures  $T_1$  and  $T_2$  are connected together to a noise source  $T$ .

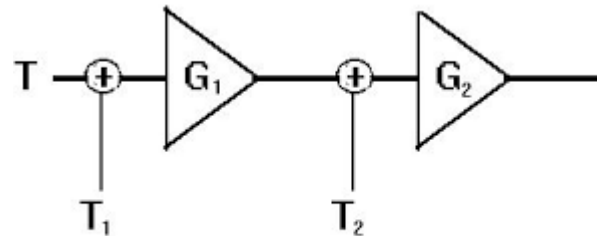

Figure 3. Two cascaded amplifiers.

The overall gain will be  $G_1 G_2$  and the noise power added by the system to  $T$  will be  $[T_1 G_1 + T_2] G_2$ . Now let's define an equivalent noise temperature for the system. We have,

$$[T_1 G_1 + T_2] G_2 = T_{eq} G_1 G_2.$$

So,  $T_{eq} = T_1 + \frac{T_2}{G_1}$

In general, for  $n$  stages, we have,

$$T_{eq} = T_1 + \frac{T_2}{G_1} + \frac{T_3}{G_1 G_2} + \dots$$



## Link Budget

---

Noise Factor is another quantity used to quantify how noisy a circuit, most often an amplifier, is. It is the ratio of the Signal-to-Noise Ratio (SNR) at the input of a circuit to the SNR at the output of the circuit. So, it can not be less than one,

$$F = \frac{SNR_{in}}{SNR_{out}} \geq 1.$$

Let the input power be  $S_{in}$  and the noise power at the input be  $N_{in} = k_B T_{in}$ .

$$\text{Then } SNR_{in} = \frac{S_{in}}{N_{in}} = \frac{S_{in}}{k_B T_{in}}.$$

Taking the gain and the noise temperature of the circuit as  $G$  and  $T$ , respectively, we have  $SNR_{out} = \frac{GS_{in}}{k_B G(T_{in}+T)}$ . Therefore,

$$F = \frac{\frac{S_{in}}{k_B T_{in}}}{\frac{GS_{in}}{k_B G(T_{in}+T)}} = 1 + \frac{T}{T_{in}}.$$

Or  $T = (F - 1)T_{in}$ . To have a common base for comparing the different amplifiers, the input (or ambient) noise temperature is fixed at 290 degrees Kelvin. So,  $T=290(F-1)$ . The noise factor in dB is called the Noise Figure,

$$NF = 10 \log(F) = 10 \log \left( 1 + \frac{T}{290} \right)$$

# Link Budget

---

- Noise Figure and Noise Temperature of system.
- Link Budget Calculation for Terrestrial Systems.
- Link Budget Calculation for Satellite Systems

# Link Budget Calculation

---

In the last lecture, we learnt how to trace the power from the output of the transmitter to the HPA to the input of the receiver. That is, we discussed about how to add to the transmitted power all the gains and subtract all the losses in order to find the received power.

$$P_r = P_t + G_t + G_r - L_s.$$

Where all quantities have been translated into dB. The linear formula (non dB) will be,

$$P_r = \frac{P_t G_t G_r}{L_s L_o}$$

Knowing  $P_r$  we can find the  $E_b = \frac{P_r}{R_b}$ .

The Path Loss, or space loss,  $L_s$  is given as,

$$L_s = \left( \frac{4\pi d}{\lambda} \right)^2.$$

This means that path loss is increased by 20 dB per decade.

This formula is valid for the cases where electromagnetic wave travels through a single path from the transmitter antenna to the receiver antenna. This is the case

---

# Link Budget Calculation

when the antennas are located far above the ground or in the case of satellite links. This is called the Line of Sight (LOS) propagation model. In terrestrial broadcasting or communications, e.g., mobile telephony, the antennas, particularly, that of the receivers, are not well above the ground surface. In these cases, in addition to the direct signal, there will be waves reflected from the ground. A method commonly used to model this situation is the two-ray model.

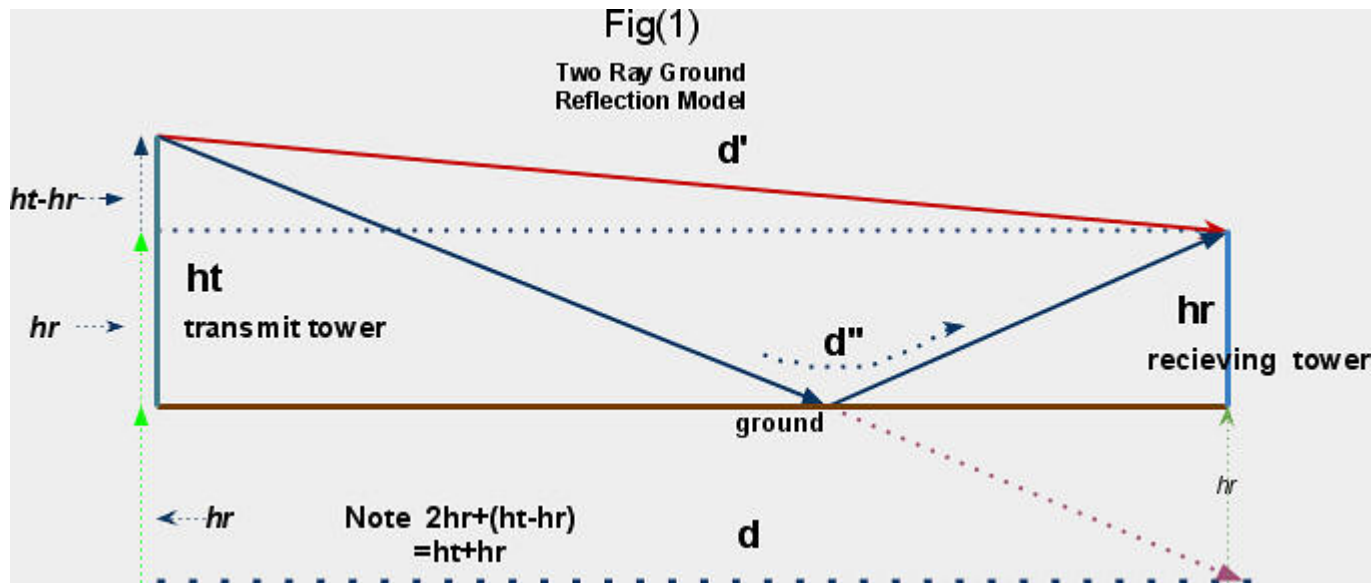

## Link Budget Calculation

---

In this model, in addition to the direct ray, another wave reflected from the ground reaches the receiver antenna. For this model,

$$P_r = P_t G_t G_r \frac{h_t^2 h_r^2}{d^4}.$$

Note that here the loss is -40 dB per decade.

We also saw that  $N_0 = k_B T$ , where  $T$  is the noise spectral density at the receiver. We also showed that the overall noise temperature of a cascade of circuits with gains  $G_1, G_2, G_3, \dots$  and noise temperatures  $T_1, T_2, T_3, \dots$  is,

$$T_{eq} = T_1 + \frac{T_2}{G_1} + \frac{T_3}{G_1 G_2} + \dots$$

Where the first term  $T_1$  is the noise temperature of the first component in the cascade referred to the input.

In communications (including broadcasting) systems, the receiver antenna is connected to the first component in the receiver chain and the noise temperature of the antenna  $T_{ant}$  is given at its output. So,  $T_{ant}$  and  $T_1$  are both at the input of the first stage of the cascade.

## Link Budget Calculation

---

Therefore, we have,

$$T_{eq} = T_{ant} + T_1 + \frac{T_2}{G_1} + \frac{T_3}{G_1 G_2} + \dots$$

or

$$T_{eq} = T_{ant} + T_{sys}$$

where,

$$T_{sys} = T_1 + \frac{T_2}{G_1} + \frac{T_3}{G_1 G_2} + \dots$$

Another quantity we discussed was the noise factor  $F$  and we saw that the relationship between the noise factor  $F$  and the noise temperature  $T$  is,  $F = 1 + \frac{T}{T_{in}}$  or  $T = (F - 1)T_{in}$  where  $T_{in}$  is a reference noise temperature at the input of the amplifier. It is usually assumed to be 290 degrees Kelvin.

# Link Budget Calculation

Noise factor when represented in dB is called the Noise Figure (NF). That is,  $NF = 10\log(F)$ . So,

$$T = 290(F - 1) = 290\left(10^{\frac{NF}{10}} - 1\right).$$

$$NF = 10\log\left(\frac{T}{290} + 1\right)$$

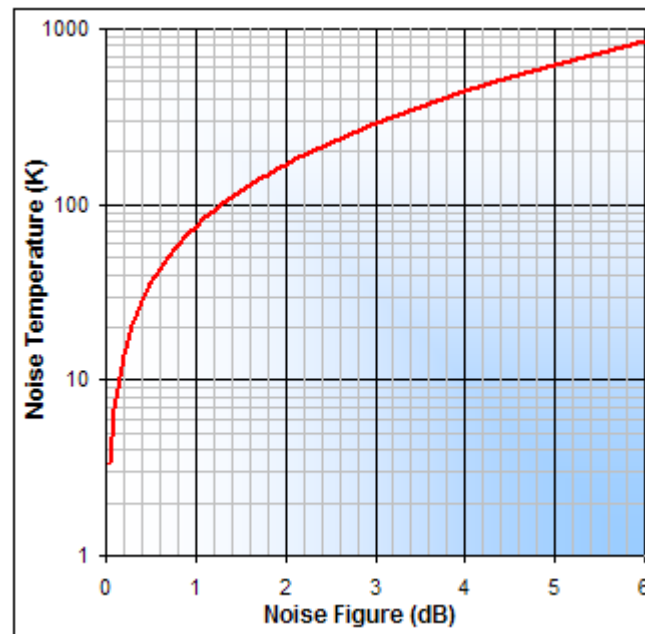

## Link Budget Calculation

---

Explaining noise temperature, noise factor or noise figure is easy for the active components, i.e., those that amplify the signal. But for passive components the subject is sometimes puzzling.

Take a lossy line such as a coaxial cable. It attenuates the signal by a factor  $L$ . We say that the loss of the line is  $L$ . This can be considered as a gain less than unity  $G=1/L$ .

The signal at the input of the line will be attenuated by  $L$  and be  $S_{out} = \frac{S_{in}}{L}$  at the end of the line. But the noise remains unchanged,  $N_{out} = N_{in}$ . So,

$$SNR_{out} = \frac{S_{in}/L}{N_{in}}$$

Therefore,  $F = L$  or  $T = 290(L - 1)$ .

**Example:** A low noise amplifier with equivalent noise temperature of  $30^\circ \text{ K}$  and power gain of  $20 \text{ dB}$  is connected with a microwave receiver with a noise figure of  $25 \text{ dB}$ . What is the overall noise temperature if the ambient temperature is  $27^\circ \text{ C}$ .

**Solution:**  $T_e = T_1 + \frac{T_2}{G_1}$  where  $T_1 = 30^\circ \text{ C}$  and  $G_1 = 20 \text{ dB} = 100$ .

$NF_2 = 25 \text{ dB}$ . So,  $F_2 = 10^{2.5} = 316.23$ .



## Link Budget Calculation

$$T_2 = T_{ref}(F_2 - 1) = 300(316.23 - 1) \approx 94568.$$

$$\text{So } T_{eq} = 30 + \frac{94568}{100} = 975.68^\circ K.$$

**Example:** Assume that a preamplifier with a gain of 20 dB and noise figure of 6 dB is connected to a receiver with a cable with a 3 dB loss.

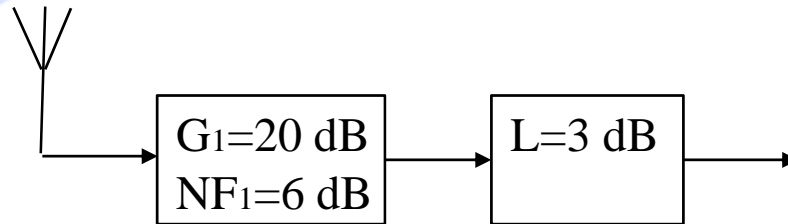

- Find the system equivalent noise temperature.
- Find the system equivalent noise temperature if the antenna is connected to the amplifier via the cable.

**Solution:** a)  $T_{eq} = T_1 + \frac{T_2}{G_1}$  where  $T_1 = 290(10^{0.6} - 1) \approx 870^\circ K$ ,  $G_1 = 10^2 = 100$

and  $T_2 = 290(L - 1) = 290(2 - 1) = 290$ . So,  $T_{eq} = 870 + \frac{290}{100} = 872.9^\circ K$ .

b)  $T_{eq} = T_2 + \frac{T_1}{1/L} = T_2 + T_1 L = 290 + 870 \times 2 = 2030^\circ K$ .

## Link Budget Calculation

---

After finding the noise temperature  $T$  for the system, we can use the formula  $N_0 = k_B T$  to find the noise spectral density. Having the  $E_b$  and  $N_0$ , now we can have the performance of the system. That is given the type of modulation, we use the  $\frac{E_b}{N_0}$  to find the bit error rate (BER).

A more common practice is to approach the problem from two different ways and see whether they match or not:

First: We start from the requirement, i.e., the BER required for a given application and for a given available bandwidth and bit rate, find the  $\left(\frac{E_b}{N_0}\right)_{req}$ . This is the  $\frac{E_b}{N_0}$  required to achieve the desired performance.

Second: We start from the system components and find the actual  $\frac{E_b}{N_0}$  as described in the previous slides. If this available  $\frac{E_b}{N_0}$  exceeds the  $\left(\frac{E_b}{N_0}\right)_{req}$  we are safe. That is the link performs as we wished. Else, we need to add something to increase the  $\frac{E_b}{N_0}$ . This may include increasing the transmitter power, size of the antennas, reducing the rate, etc. The difference between the  $\frac{E_b}{N_0}$  and  $\left(\frac{E_b}{N_0}\right)_{req}$  is called the link margin,

---

# Link Budget Calculation

---

Always remember that subtraction of this sort can only be used when the quantities are in dB and not ratio.

$$M = \frac{E_b}{N_0} - \left( \frac{E_b}{N_0} \right)_{req}$$

**Example:** Assume that a Television station is transmitting an HDTV signal with a bit rate of 15 Mbps in a 6 MHz. bandwidth using MPSK with roll-off factor 0.2. The requirement is that no more than one packet of TS be dropped in an hour. Assume that a packet is dropped if there is any error in it. The power of the transmitter is 300 W and the transmitter antenna gain is 15 dBi. The receiver antenna has a gain of 5 dBi and noise temperature  $2500^\circ$  K. The receiver has an LNB with NF=6 dB and  $G_{LNA} = 20$  dB connected with a cable with 4 dB loss to an amplifier with 30 dB gain and NF=16. The receiver, including the receiver front end and the demodulator, has a noise figure of 10 dB. Assuming a pointing loss of 0.5 dB and implementation loss of 1.5 dB. If the transmission frequency is 700 MHz., find the maximum distance the station can cover with the required quality: a) without FEC 2) with RS coding. Transmitter antenna is at the height of  $h_t = 25$  m and the receive antenna is located at  $h_r = 5$  m.

# Link Budget Calculation

---

Solution:

$$W = R_s(1 + \beta)$$

So,

$$6 = R_s(1 + 0.2) \text{ or } R_s = 5 \text{ M} \frac{\text{symbols}}{\text{sec}}$$

and

$$\log_2 M = \frac{R_b}{R_s} = 3 \text{ and } M = 8.$$

For 8PSK, we have,

$$BER \approx \frac{2}{3} Q \left( \sqrt{6 \frac{E_b}{N_0}} \sin \frac{\pi}{8} \right)$$

Let's now find the required BER:

The rate of the video is 15 Mbps. The length of each TS packet is  $188 \times 8 = 1504$  bits. So, there are approximately 9973 packets per second. Requiring that we get one lost packet per hour means that the packet error probability should be less than  $2.79 \times 10^{-8}$ .

---

## Link Budget Calculation

---

If the BER is  $p$  then we need to have

$$1 - (1 - p)^{1504} \approx 1504p \leq 2.79 \times 10^{-8}$$

or  $p \leq 1.85 \times 10^{-11}$ .

From:

$$1.85 \times 10^{-11} \approx \frac{2}{3} Q \left( \sqrt{6 \frac{E_b}{N_0} \sin \frac{\pi}{8}} \right)$$

we get  $\frac{E_b}{N_0} = 59 = 17.7 \text{ dB}$ .

Now, we try to find  $P_r$ :

$$P_r = P_t + G_t + G_r - L_s - L_o = 24.77 + 15 + 5 - L_s - 0.5 - 1.5$$

So,  $P_r = 42.77 - L_s$  and,

$$E_b = \frac{10^{4.277 - \frac{L_s}{10}}}{15 \times 10^6}$$

To find the noise temperature:

$$T_{eq} = T_{ant} + T_{LNA} + \frac{T_C}{G_{LNA}} + \frac{T_{AMP}}{G_{LNA}G_C} + \frac{T_{rec}}{G_{LNA}G_CG_{AMP}}$$

## Link Budget Calculation

---

Where

$$T_{ant} = 2500^\circ \text{ K.}$$

$$T_{LNA} = 290(10^{0.6} - 1) \approx 864.5^\circ \text{ K and } G_{LNA} = 100.$$

$$T_C = 290(10^{0.4} - 1) \approx 438.4^\circ \text{ K and } G_C = 0.5.$$

$$T_{AMP} = 290(10^{0.9} - 1) \approx 2013.55^\circ \text{ K and } G_{AMP} = 1000.$$

$$T_{rec} = 290(10 - 1) = 2610^\circ \text{ K.}$$

So,

$$T_{eq} = 2500 + 864.5 + \frac{438.4}{100} + \frac{2013.55}{100 \times 0.5} + \frac{2610}{100 \times 1000 \times 0.5} = 3409.2^\circ \text{ K.}$$

$$\text{Therefore, } N_0 = k_B T_{eq} = 1.38 \times 10^{-23} \times 3409.2 \approx 4.7 \times 10^{-20}.$$

Letting  $\frac{E_b}{N_0} = 59$ , we get,

$$\frac{E_b}{N_0} = \frac{10^{4.277 - \frac{L_S}{10}}}{15 \times 10^6 \times 4.7 \times 10^{-20}} = 59.$$

Or  $L_S = 146.58 \text{ dB}$

Remember that  $L_S = 10 \log \left( \frac{4\pi d}{\lambda} \right)^2$  for the LOS where  $\lambda = \frac{3 \times 10^8}{700 \times 10^6} = \frac{3}{7} \text{ m.}$

Solving for d we get a tremendously large number indicating that this model is not valid for this case.

---

## Link Budget Calculation

---

So, we use the tow-ray model, i.e.,

$$L_s = 10 \log \frac{d^4}{h_t^2 h_r^2}$$

Solving for  $d$ , we get  $d \approx 50 \text{ km}$ .

Now, let's use the (204,188) Reed Solomon code. We can do that by either increasing the bandwidth by a ratio of  $204/188=1.085$ , i.e., by 9% increase in bandwidth cost or a reduction in the rate of encoding by  $188/204=0.92$  from 15 Mbps to 13.8 Mbps, or using a higher order modulation. Let's choose the latter option.

Now the overall bit rate will be  $R_c = 15 \times \frac{204}{188} = 16.2766 \text{ Mbps}$ . Keeping the bandwidth 6 MHz. as before, we have,

$$6 \geq \frac{16.2766}{\log_2 M} (1 + 0.2).$$

## Link Budget Calculation

---

So,  $\log_2 M \geq 3.25$ . Therefore, we have  $M=16$ . So, we use 16PSK

With RS coding, we will have a bad (erroneous) packet only if there are more than 8 bytes of error in a packet.

At the rate of 15 Mbps there are 9973 packets per second. So, in order to comply with the performance requirement, we need to less than one error every  $3600 \times 9973 = 35904255$  packets or the packet error rate should be less than  $2.79 \times 10^{-8}$ .

Probability of error is

$$P_E = \sum_{i=9}^{204} \binom{204}{i} p_c^i (1 - p_c)^{204-i}$$

Approximating this expression by taking only the first term (assuming that  $p_c$  is very small),

$$P_E \approx \binom{204}{9} p_c^9 (1 - p_c)^{195} = 2.79 \times 10^{-8}$$

Solving this, we get  $p_c \approx 3 \times 10^{-3}$ .



## Link Budget Calculation

---

So, the required BER is  $\approx 3.75 \times 10^{-4}$

Substituting this in the formula for BER of 16 PSK, we get,

$$3.375 \times 10^{-4} = \frac{1}{2} Q \left( \sqrt{8 \frac{E_b}{N_0}} \sin \left( \frac{\pi}{16} \right) \right)$$

Solving for  $\frac{E_b}{N_0}$  we get  $\frac{E_b}{N_0} = 62.5$

$$L_s = 10 \log \frac{d^4}{h_t^2 h_r^2}$$

Letting

$$\frac{E_b}{N_0} = \frac{10^{11.277 - \frac{L_s}{10}}}{15 \times 10^6 \times 4.7 \times 10^{-20}} = 62.5.$$

We get  $L_s \approx 153 \text{ dB}$ .

$$L_s = 10 \log \left( \frac{4\pi d}{\lambda} \right)^2 = 153.$$

Solving for  $d$ , we get  $d \approx 74.72 \text{ km}$ .

---