

Lecture 8:

In this lecture, we discuss some new techniques used in modern communication systems. When we say "new", we do not mean that these techniques have been introduced recently, but, we emphasize the fact that their use has become widespread recently.

Among these techniques we include Orthogonal Frequency Division Multiplexing (OFDM) and Code Division Multiple Access (CDMA).

In talking about CDMA, we also talk (briefly) about other multiple Access Techniques such as TDMA and FDMA.

OFDM:

In the transmission techniques we discussed so far, we assumed that the only channel impairment is the AWGN, i.e., a noise that is distributed according to Gaussian law, has no memory (is white) and adds to the transmitted signal. That is

$$y_n = s_n + w_n$$

where y_n is the received signal at time n and s_n and w_n are the signal and noise components of it at time n (more accurately at time $t = nT_b$).

In another word, we have assumed that the channel treats the signal uniformly over the time and irrespective of the frequency.

Now consider a situation where the signal going through the channel is attenuated to different degrees depending on the

frequency band over which it is transmitted. In such a case as long as the bandwidth of the signal is small, we can assume that different components of the signal have gone through the same channel impairment and use the simple model we discussed before.

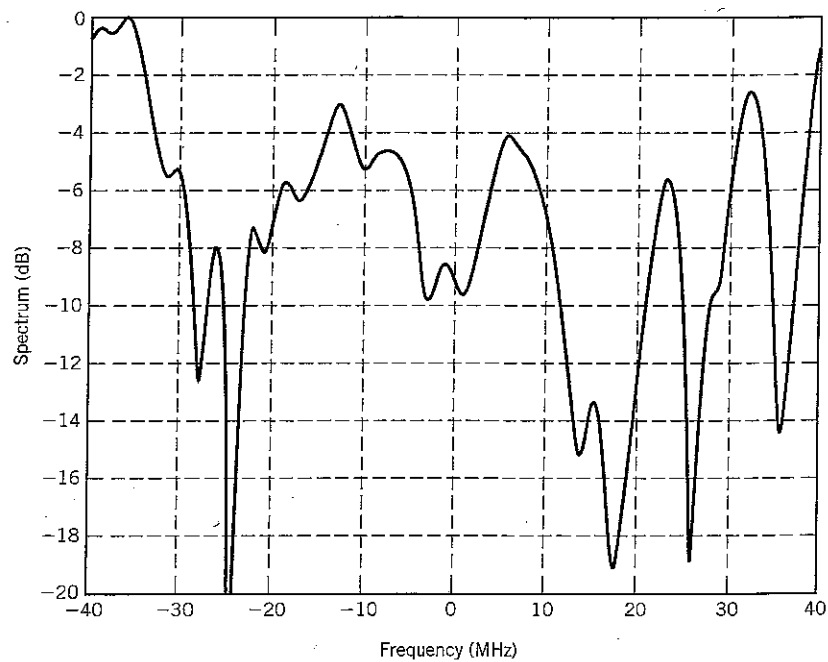

Example amplitude spectrum of wireless LAN channel.

But if the bandwidth is large (wideband signal) then different parts of the spectrum are treated differently. In such a case, it is a good idea to break the total signal spectrum into smaller chunks and transmit

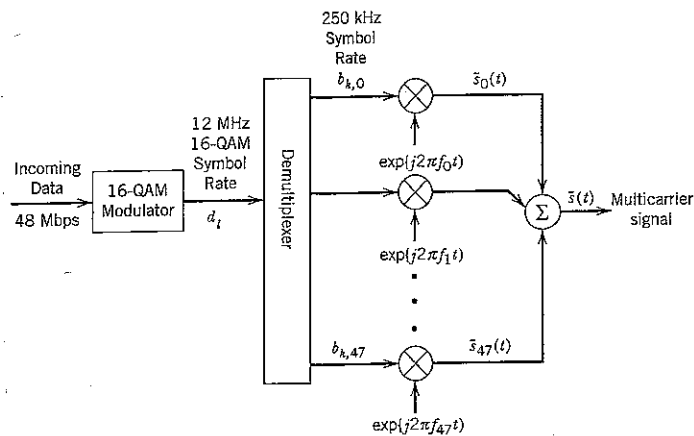

Illustration of conceptual OFDM modulation process.

That is, the overall modulated waveform is the sum of sub symbols modulated on different sub-carriers, i.e.,

$$\tilde{s}(t) = \sum_{n=0}^{47} \tilde{s}_n(t)$$

where,

$$\tilde{s}_n(t) = b_{k,n} p(t - kT) e^{j2\pi f_k t}, \quad (k-1)T \leq t \leq kT$$

$p(t)$ is the pulse shaping waveform and $b_{k,n}$ is the k -th QAM symbol at time n .

The complex amplitude $\tilde{s}_n(t)$ is then modulated on a carrier $e^{j2\pi f_k t}$ and then the real part: the cosine is transmitted.

Mathematically, it can be written as

$$s(t) = \text{Re} [\tilde{S}(t) e^{j2\pi f_c t}]$$

Note that in each symbol period time,

48 QAM symbols are transmitted and each QAM symbol represents 4 bits.

So, $48 \times 4 = 192$ bits are transmitted in each symbol period.

No, assume that the T second symbol interval is divided into M time instants $t_m = \frac{mT}{M}$

$m = 0, 1, \dots, M-1$. (In our example $M = 48$)

Then,

$$\tilde{S}(t_m) = \tilde{S}\left(\frac{mT}{M}\right) = \sum_{n=0}^{M-1} b_{k,n} e^{j\frac{2\pi mn}{M}} \quad m = 0, 1, \dots, M-1$$

If we refer to the Discrete Fourier Transform (DFT) and inverse DFT (IDFT)

formulas:

$$\left. \begin{array}{l} \text{DFT: } b_n = \sum_{m=0}^{M-1} B_m \exp(-j2\pi mn/M) \quad n = 0, 1, \dots, M-1 \\ \text{IDFT: } B_m = \frac{1}{M} \sum_{n=0}^{M-1} b_n \exp(j2\pi mn/M) \quad m = 0, 1, \dots, M-1 \end{array} \right\}$$

we observe that $\tilde{S}\left(\frac{mT}{M}\right)$ is the inverse

Fourier Transform of the sequence $\{b_{k,n}\}$

Based on this, we can draw the block diagram of the transmitter and receiver of the OFDM as follows:

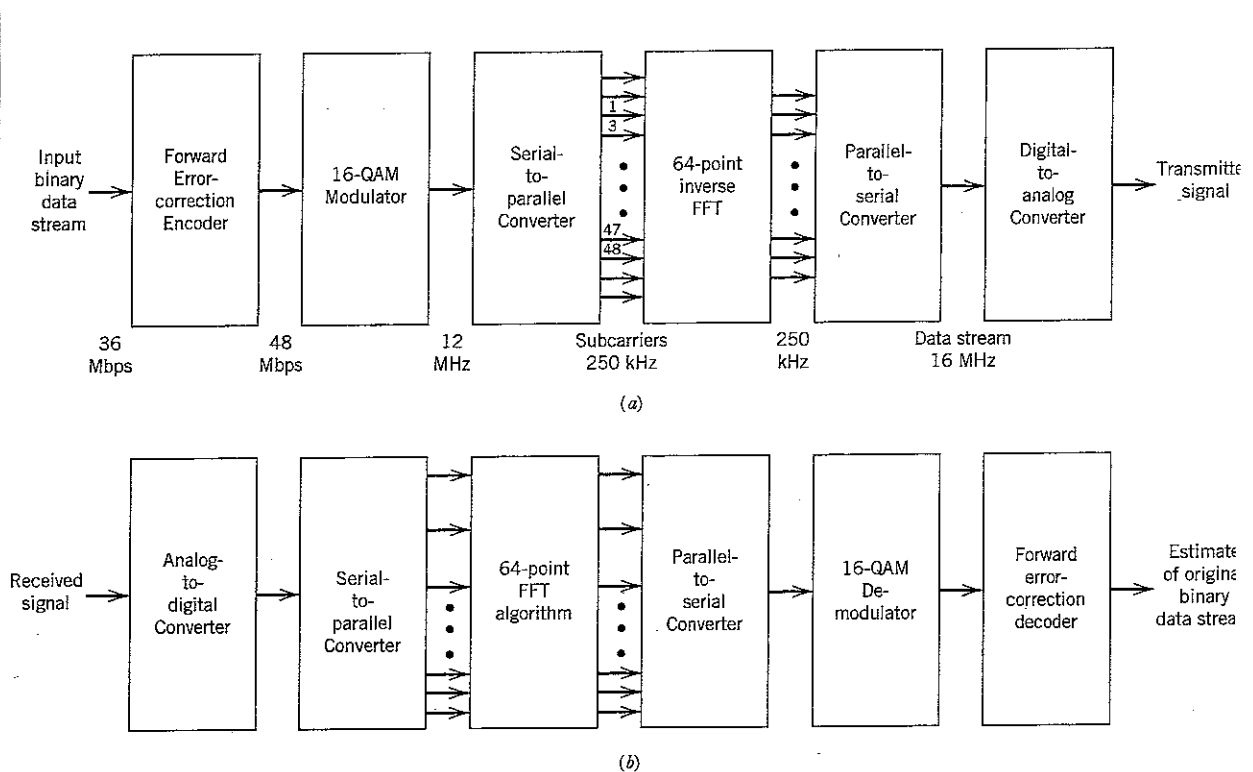

Block diagram of (a) OFDM transmitter, and (b) OFDM receiver.

The 4G standard LTE (Long Term Evolution) uses OFDM and also OFDMA (Orthogonal Frequency Division Multiple Access). The TV broadcast standard DVB-T also uses OFDM. The FFT size is either 2k (2024) or 8k. DVB-H (DVB for handheld) also uses 4k FFT. The example given in this

lecture with $M=48$ is used in Wi-Fi (802.11 standard). In fact a size 64 FFT is used with 16 of the bins filled with zero's.

Multiple Access Schemes:

In a communication system, there are many pairs of transmitter/receivers communicating with each other simultaneously. Therefore, the communication resources have to be divided between the different users.

This is particularly important in the case of over the air (wireless or satellite) communications where all users utilize the same medium. There are different ways of resource sharing. The basic ones are

- Frequency Division Multiple Access (FDMA)
- Time Division Multiple Access (TDMA)
- Code Division Multiple Access (CDMA)

Multiple Access Schemes:

- FDMA

- TDMA

- CDMA

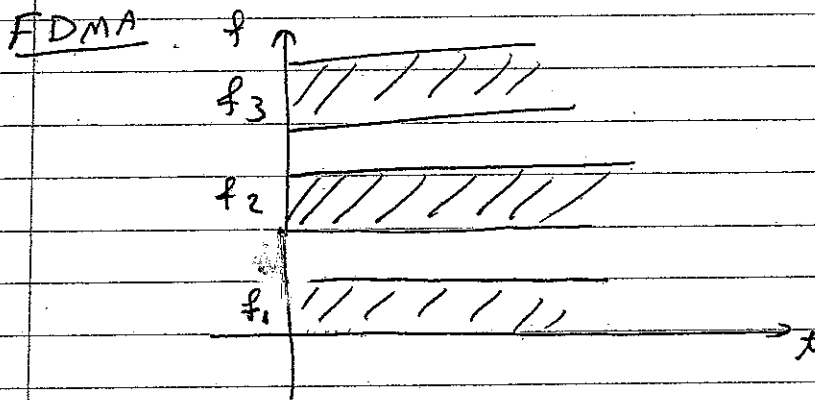

advantage: transmission at the rate that you

have (your data rate = transmission rate)

\Rightarrow small low power \Rightarrow small transmitter.

disadvantage: lack of flexibility.

TDMA:

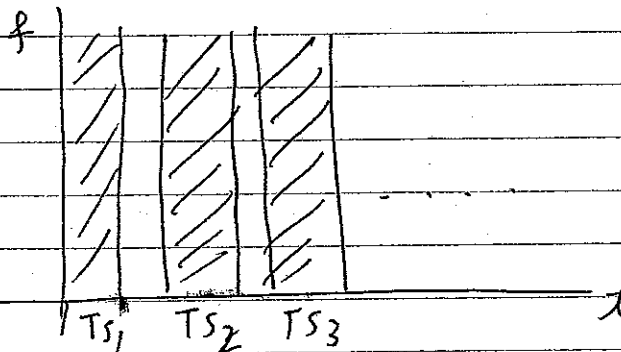

advantage: flexibility: you transmit more by transmitting longer (in more than one time slot)

disadvantage: large peak to average power since each user transmits at the aggregate rate and not his own rate.

Combined TDMA/FDMA

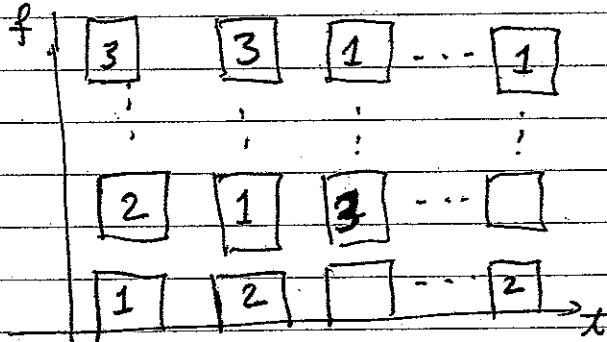

CDMA: Code Division Multiple Access (SS)

In this scheme all users occupy "all" the bandwidth "all" the time: However, they use different spreading codes.

SS CDMA Types:

- FH-SS

- DS-SS (usually called CDMA) although FH is also CDMA.

Pseudo-noise (PN) Sequences

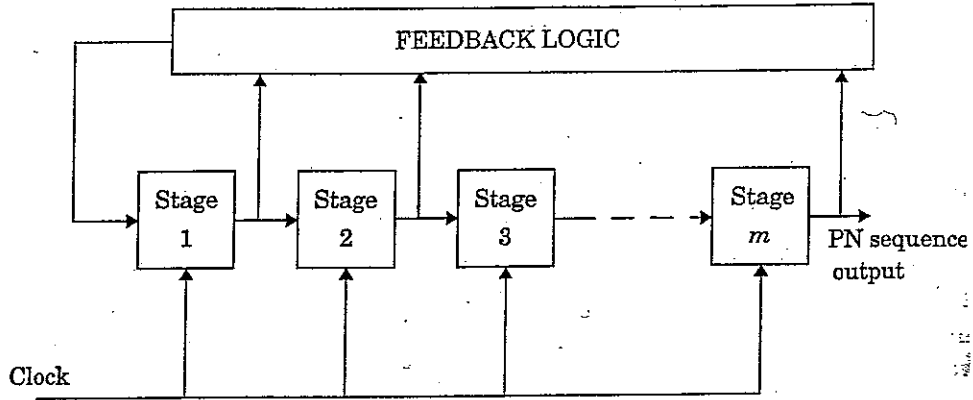

Figure 5.48
Block diagram of a generalized feedback shift register with m stages.

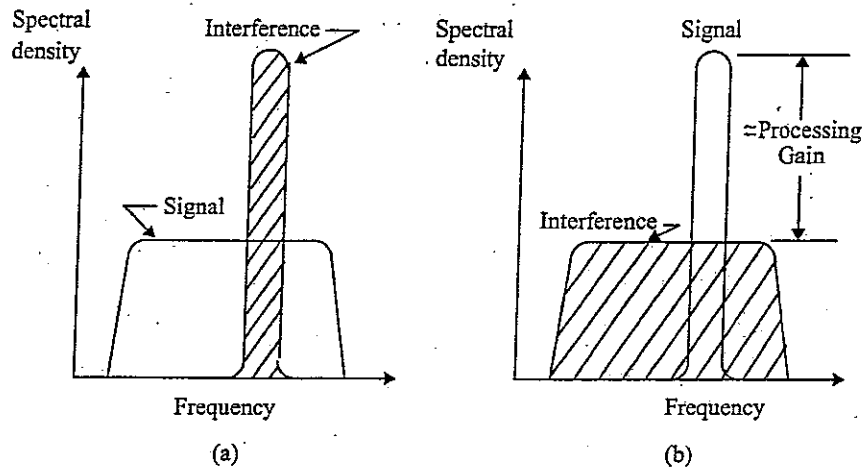
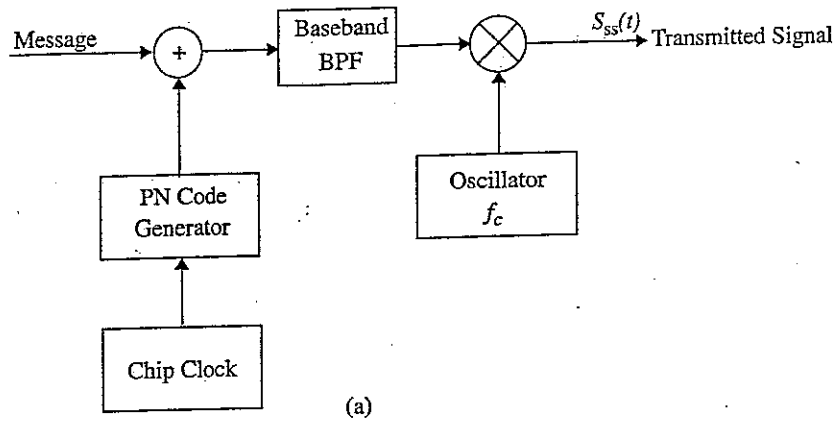

Figure 5.50
Spectra of desired received signal with interference: (a) wideband filter output and (b) correlator output after despreading.

$$PG = \frac{T_s}{T_c} = \frac{R_c}{R_s} = \frac{W_{ss}}{2R_s}$$

Direct Sequence Spread Spectrum (DS-SS)



$$S_{ss}(t) = \sqrt{\frac{2E_s}{T_s}} m(t) p(t) \cos(2\pi f_c t + \theta)$$

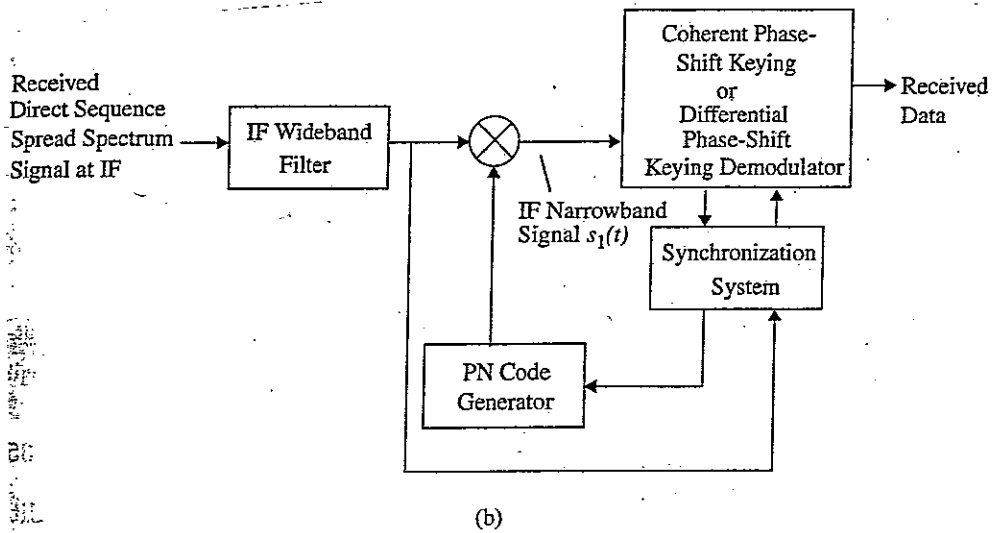

Figure 5.49
Block diagram of a DS-SS system with binary phase modulation: (a) transmitter and (b) receiver

$$s_1(t) = \sqrt{\frac{2E_s}{T_s}} m(t) \cos(2\pi f_c t + \theta)$$