

# **MECH 344/X**

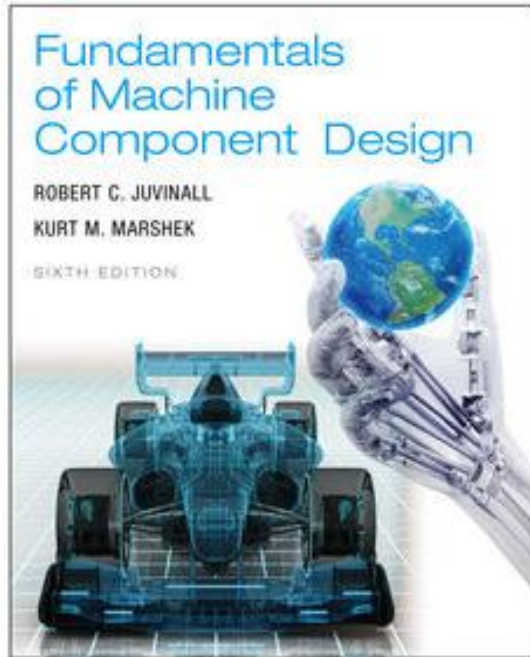
# **Machine Element Design**

**Time: M \_ \_ \_ \_ 14:45 - 17:30**

## **Lecture 1**

# Contents of today's lecture

- Introduction
- Machine Design
- Design Process
- Safety Factors



---

# Fundamentals of Machine Component Design

## Sixth Edition

Robert C. Juvinall • Kurt M. Marshek

---

# Chapter 1

## Mechanical Engineering Design in Broad Perspective

**Engineering design** is the process of applying the various techniques and scientific principles for the purpose of defining a device, a process, or a system in sufficient detail to permit its realization.

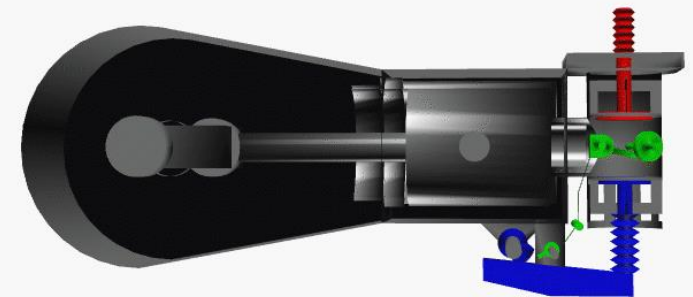
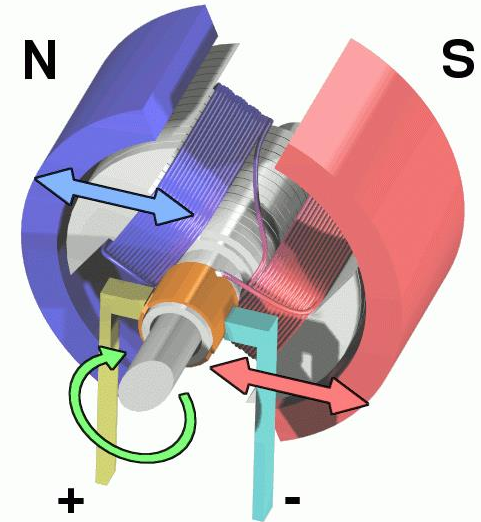
**A Machine** is:

- (1) An apparatus consisting of interrelated units, or
- (2) A device that modifies force or motion

**A Structure** has no moving parts, e.g. bridges, buildings.



- A machine is a device that transforms energy
- Has fixed and moving parts
- Connects the source of power and the work to be done
- In case of motor and generator electricity is converted to mechanical movement and vice versa
- In IC engine, connecting rod and crank shaft transfers energy



# The design process

- Design involves constrained creation
- Constraints:
  - Technology limits
  - Human and environment concerns
  - Durability and reliability
  - Cost
  - Market requirements
  - Etc.

# The design process

- REPRESENTATION
  - PERCEPTION
  - KNOWLEDGE
  - INTUITION
  - CONCEPT
  - PURE CONCEPT
  - EMPIRICAL CONCEPT
  - NOTION
  - IDEA
- Basic requirements to be able to perform a design
- All the above interacts in your judgment even if you are not aware of it
- You have to train your judgment to be able to perform solution-solving based thinking

# The design process

- A design is created after analysis, full understanding of requirements and constraints and synthesis
- Two individuals may not come with the same solution to the same problem
  - Example: Connect two straight pipes ND 4" to avoid leaking of the gas and to permit easy maintenance of the segment

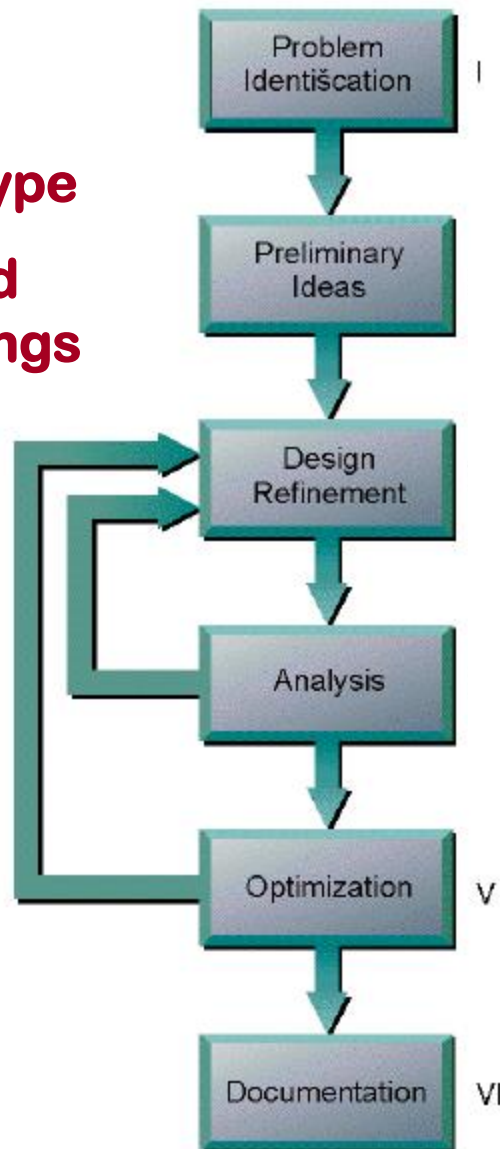


# Solutions to the problem

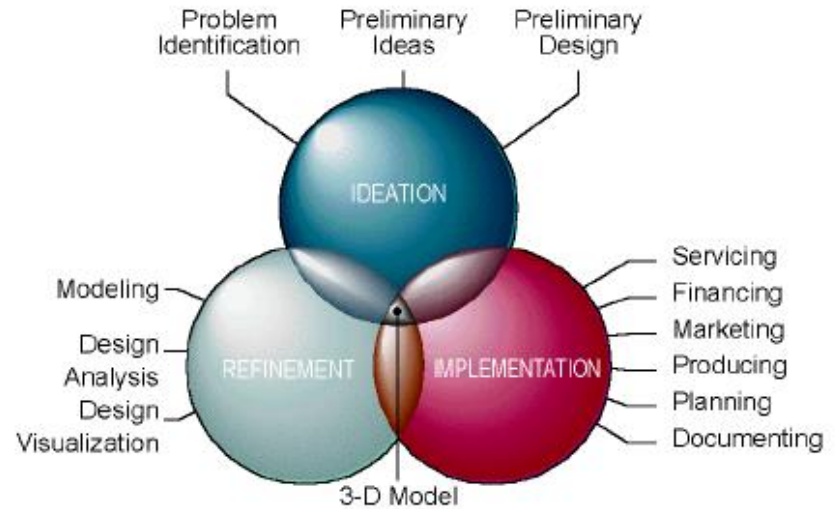
- Multiple: flanges, clips, clamps, seals, etc.



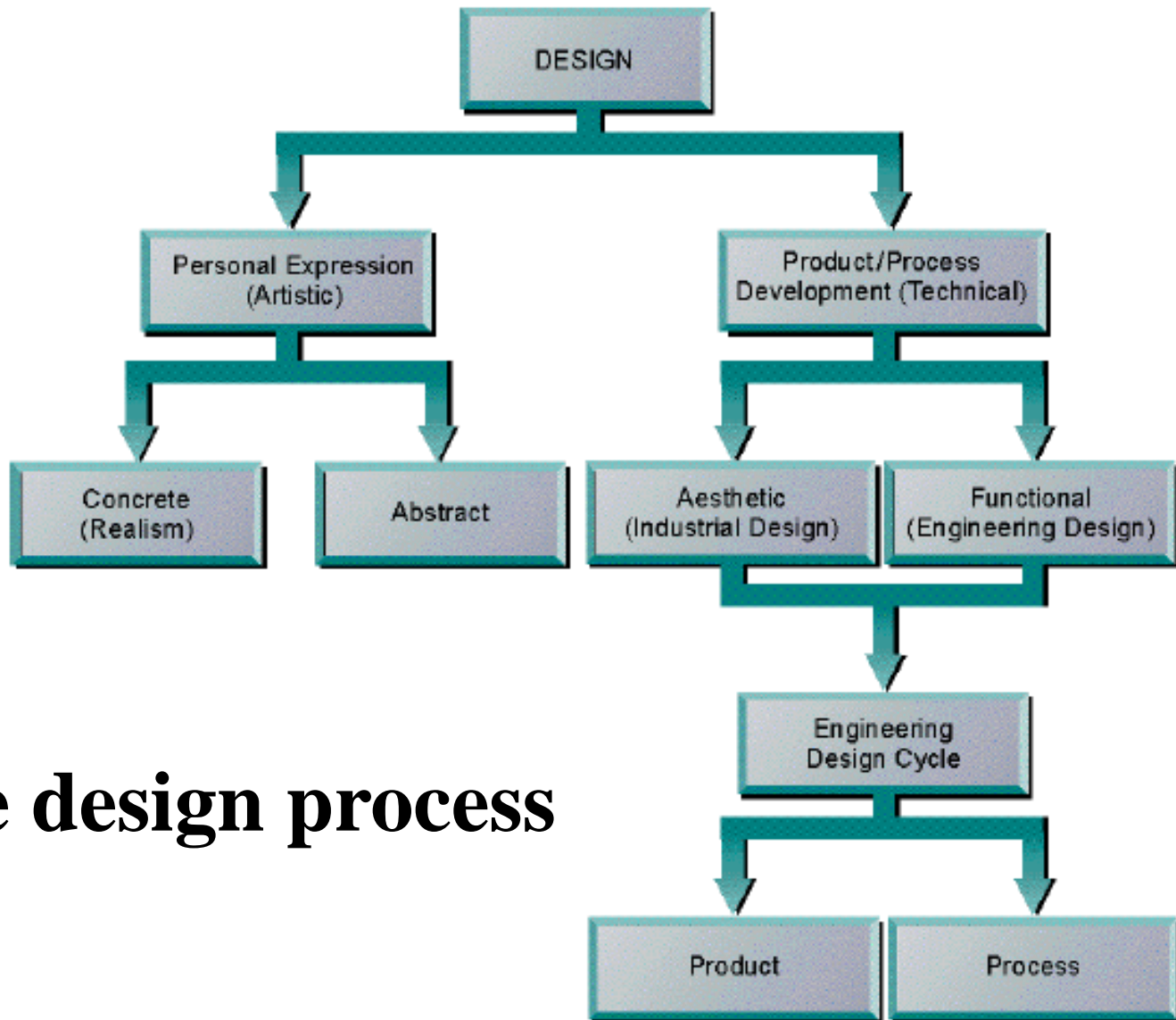
1. **Problem Defn.**
2. **Concept and ideas**
3. **Solutions**
4. **Models/Prototype**
5. **Production and working drawings**



# The design process

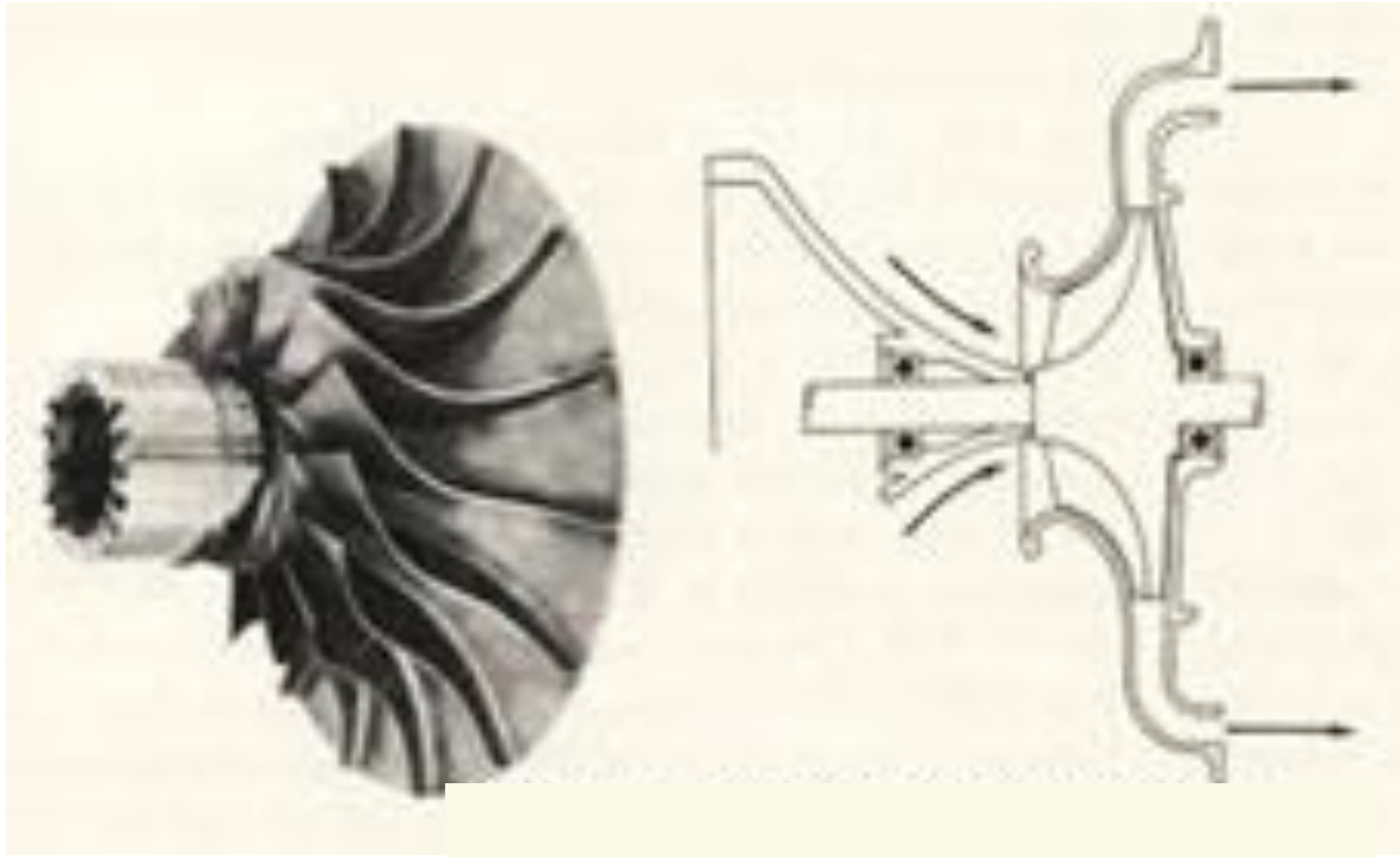


Concurrent engineering approach



# The design process

# A Component !



**TABLE 1.1** Preliminary List of Factors Constituting the Life Quality Index (LQI)

---

1. *Physical health*
  2. *Material well-being*
  3. *Safety* (crime and accident rates)
  4. *Environment* (air, water, land, and natural resource management)
  5. *Cultural–educational* (literacy rate, public school quality, college attendance among those qualified, adult educational opportunities, library and museum facilities, etc.)
  6. *Treatment of disadvantaged groups* (physically and mentally handicapped, aged, etc.)
  7. *Equality of opportunity* (and stimulation of initiative to use opportunities)
  8. *Personal freedom*
  9. *Population control*
- 

**Table 1.1**

© John Wiley & Sons, Inc. All rights reserved.

## **TABLE 1.2** Maslow's Hierarchy of Needs

---

- |                      |                     |
|----------------------|---------------------|
| 1. Survival          | 4. Status           |
| 2. Security          | 5. Self-fulfillment |
| 3. Social acceptance |                     |
-

**TABLE 1.3** Major Categories of Design Considerations

---

**Traditional Considerations**

1. Materials
2. Geometry
3. Operating conditions
4. Cost
5. Availability
6. Producibility
7. Component life

**Miscellaneous Considerations**

1. Reliability and maintainability
2. Ergonomics and aesthetics
3. Assembly and disassembly
4. Analysis

**Modern Considerations**

1. Safety
  2. Ecology
  3. Quality of life
-

**TABLE 1.4** English, British, and SI Units for Length, Time, Mass, and Force

Quantity	English Engineering [FMLt]		British Gravitational [FLt]		SI [MLt]	
	Unit	Symbol	Unit	Symbol	Unit	Symbol
Mass	pound mass	lbm	slug	slug	kilogram	kg
Length	foot	ft	foot	ft	meter	m
Time	second	s	second	s	second	s
Force	pound force (=32.1740 lbm·ft/s <sup>2</sup> )	lb (or lbf)	pound (=1 slug·ft/s <sup>2</sup> )	lb	newton (=1 kg·m/s <sup>2</sup> )	N

**Table 1.4**

© John Wiley &amp; Sons, Inc. All rights reserved.






System of Units	Standard Objects	Mass (of standard object)	Weight (standard earth gravitational field)	Constant of Proportionality	Newton's Second Law
English Engineering [FMLt]		1 lbm	1 lb	$g_c = 32.1740 \frac{\text{ft} \cdot \text{lbm}}{\text{lb} \cdot \text{s}^2}$	$\mathbf{F} = ma/g_c$
British Gravitational [FLt]		1 slug (=32.2 lbm)	32.2 lb	1	$\mathbf{F} = ma$
SI [MLt]		1 kg (=2.2046 lbm)	9.81 N (=2.2046 lb)	1	$\mathbf{F} = ma$

Figure 1.3

© John Wiley & Sons, Inc. All rights reserved.

---

**Table 1-1     A Design Process**

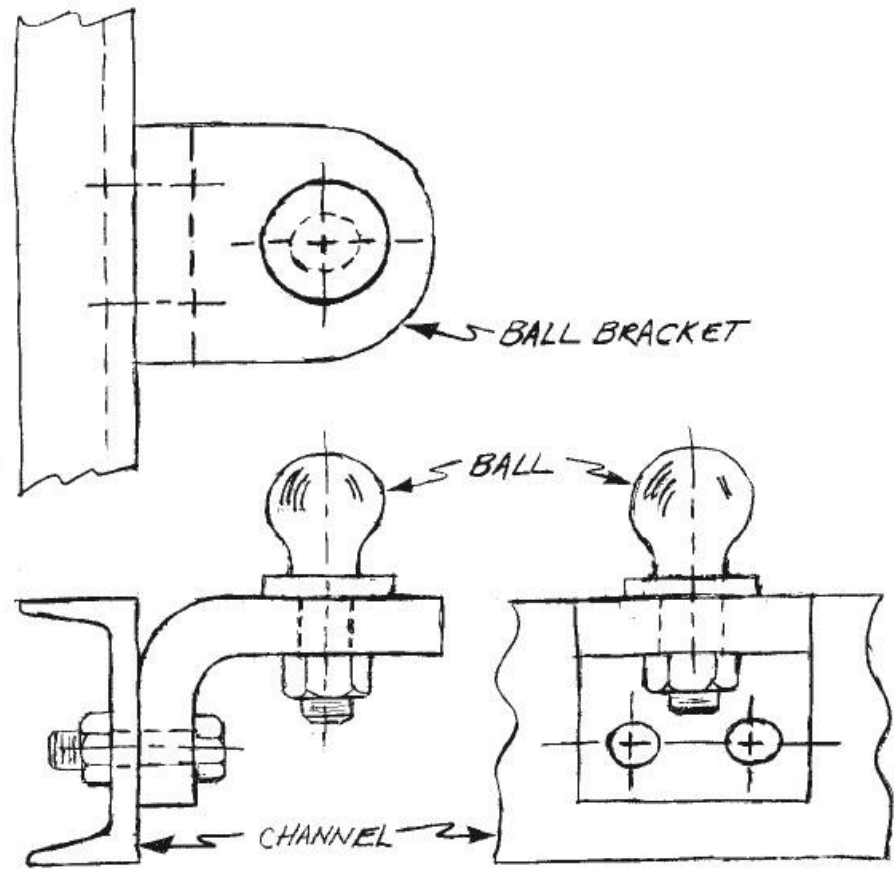
---

1	Identification of need
2	Background research
3	Goal statement
4	Task specifications
5	Synthesis
6	Analysis
7	Selection
8	Detailed design
9	Prototyping and testing
10	Production

---

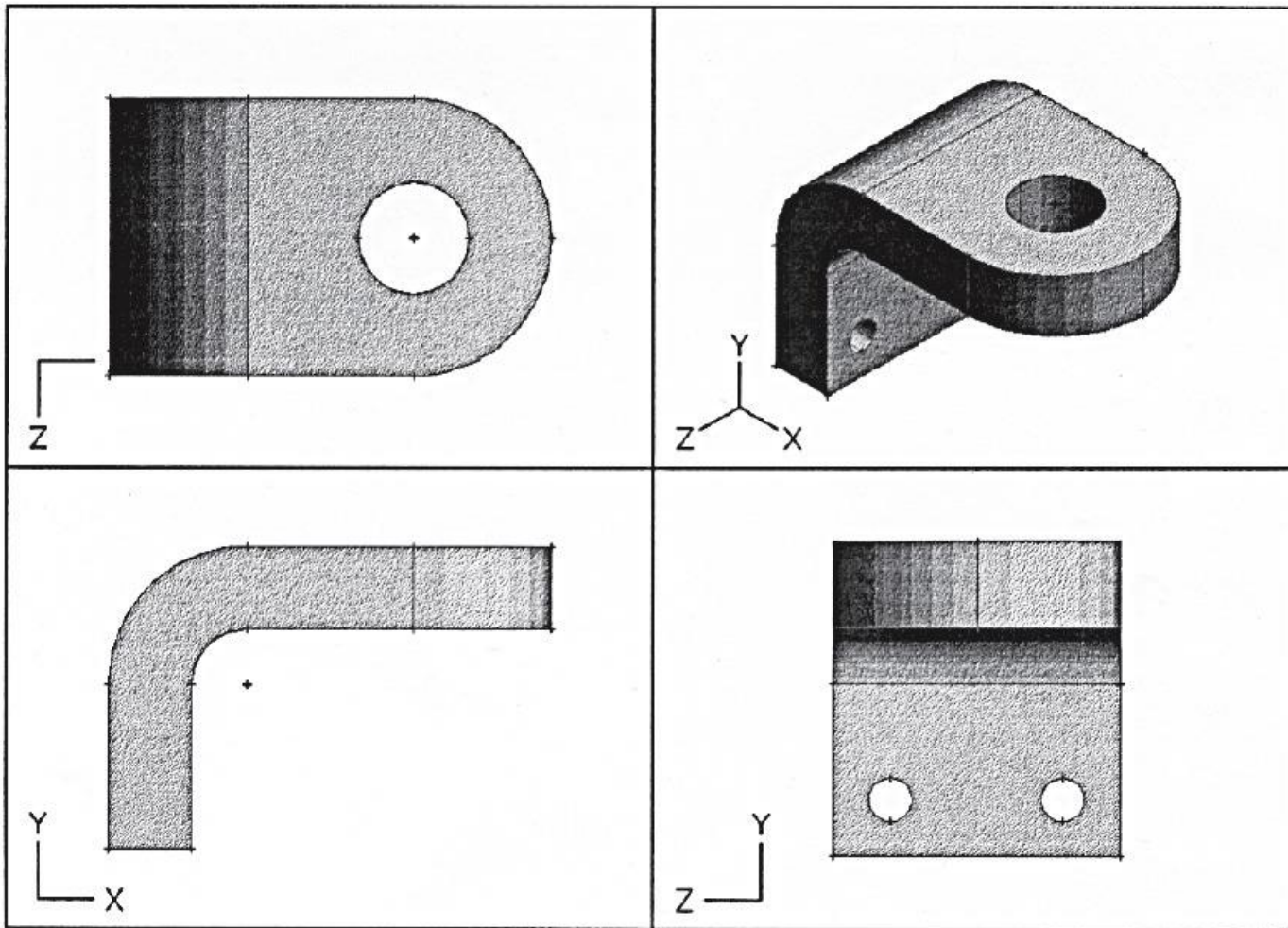
**Table 1-2 Problem Formulation and Calculation**

1	Define the problem		Definition stage
2	State the givens		
3	Make appropriate assumptions		
4	Preliminary design decisions		Preliminary design stage
5	Design sketches		
6	Mathematical models		Detailed design stage
7	Analysis of the design		
8	Evaluation		
9	Document results		Documentation stage

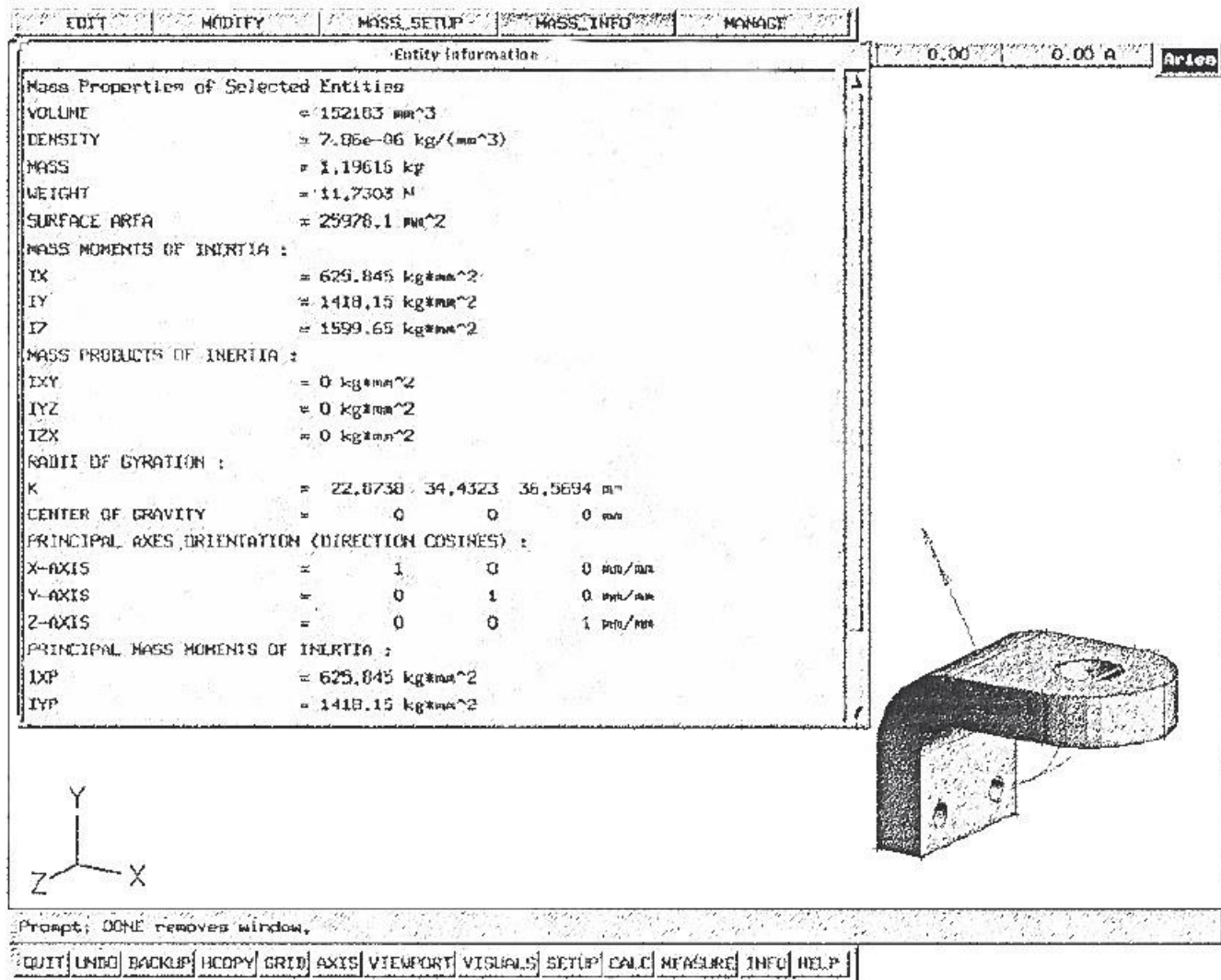


**FIGURE 1-1**

A Freehand Sketch of a Trailer Hitch Assembly for a Tractor

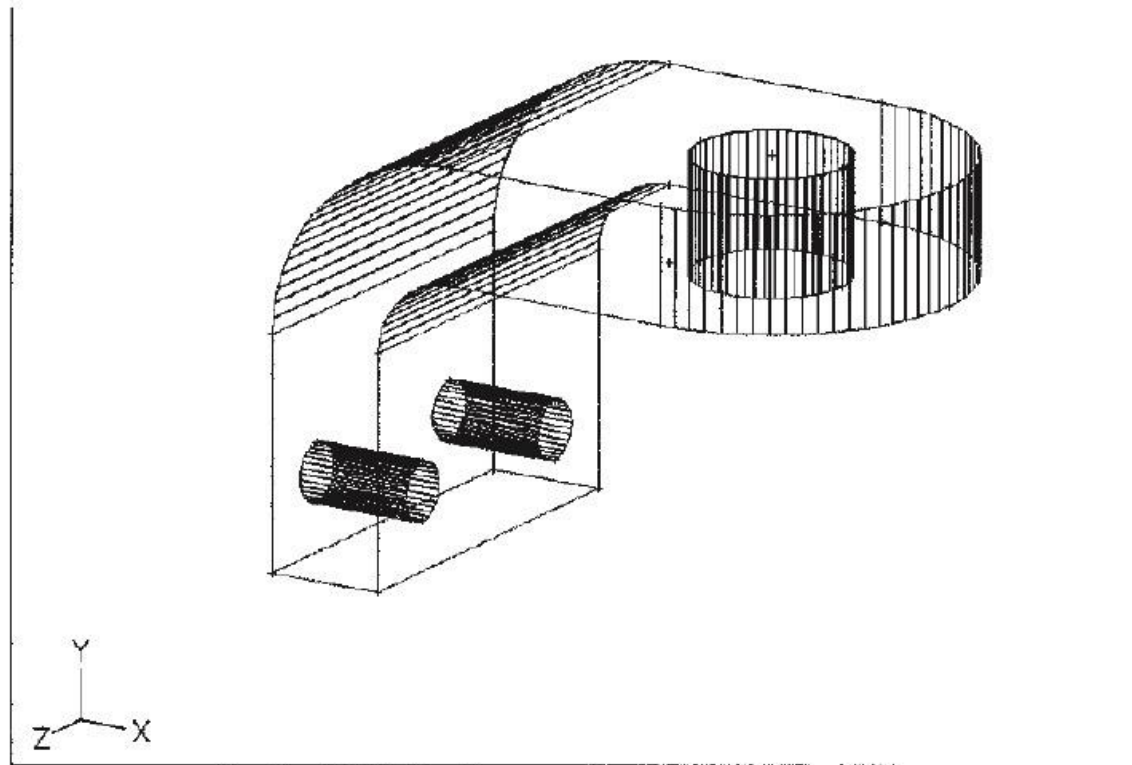
**FIGURE 1-2**

A CAD Solid Model of the Ball Bracket from the Trailer Hitch Assembly of Figure 1-1



**FIGURE 1-3**

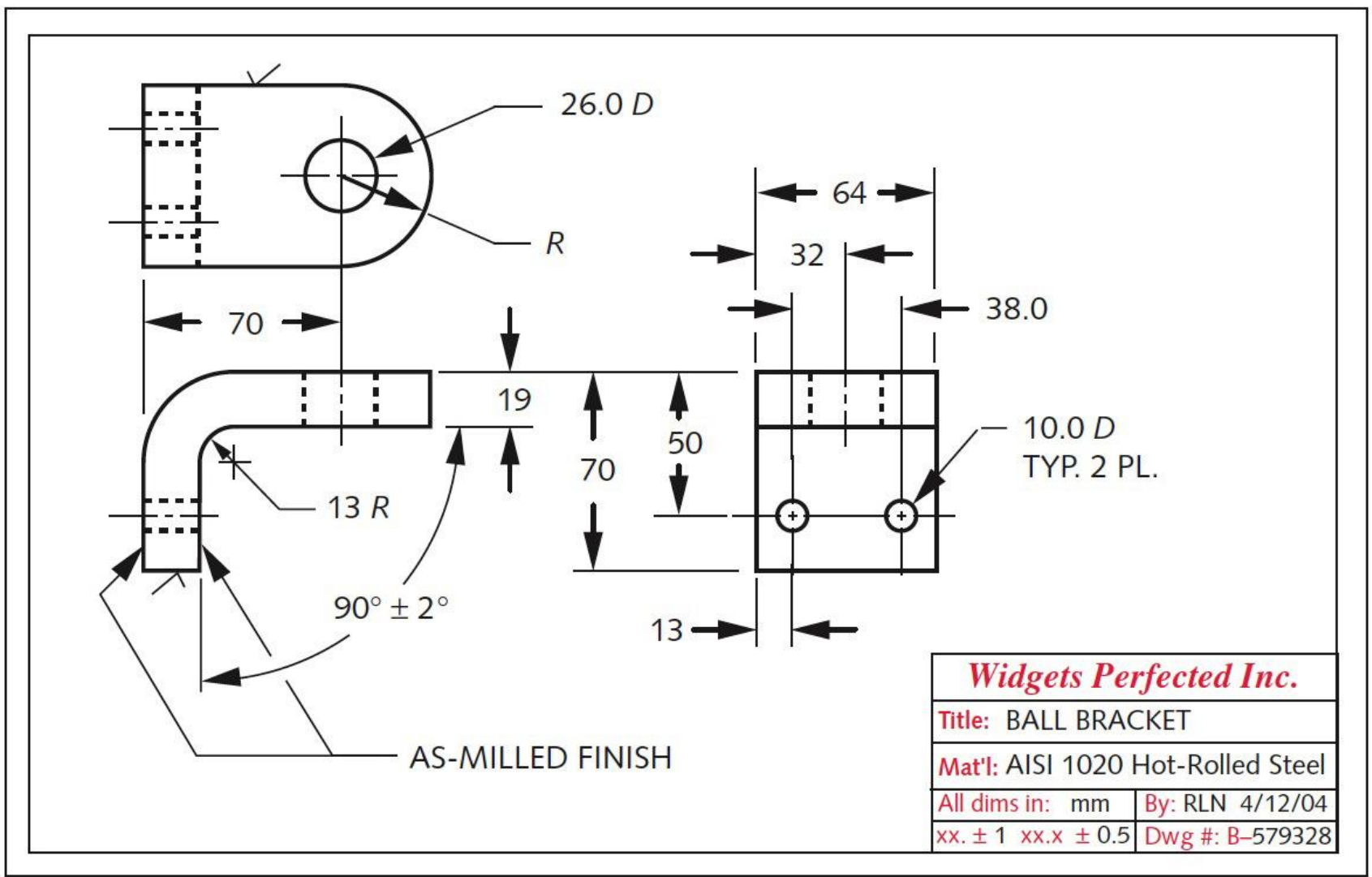
Mass Properties of the Ball Bracket Calculated Within the CAD System from Its Solid Model



**FIGURE 1-4**

A Wireframe Representation of the Ball Bracket Generated from Its Solid Model in a CAD System

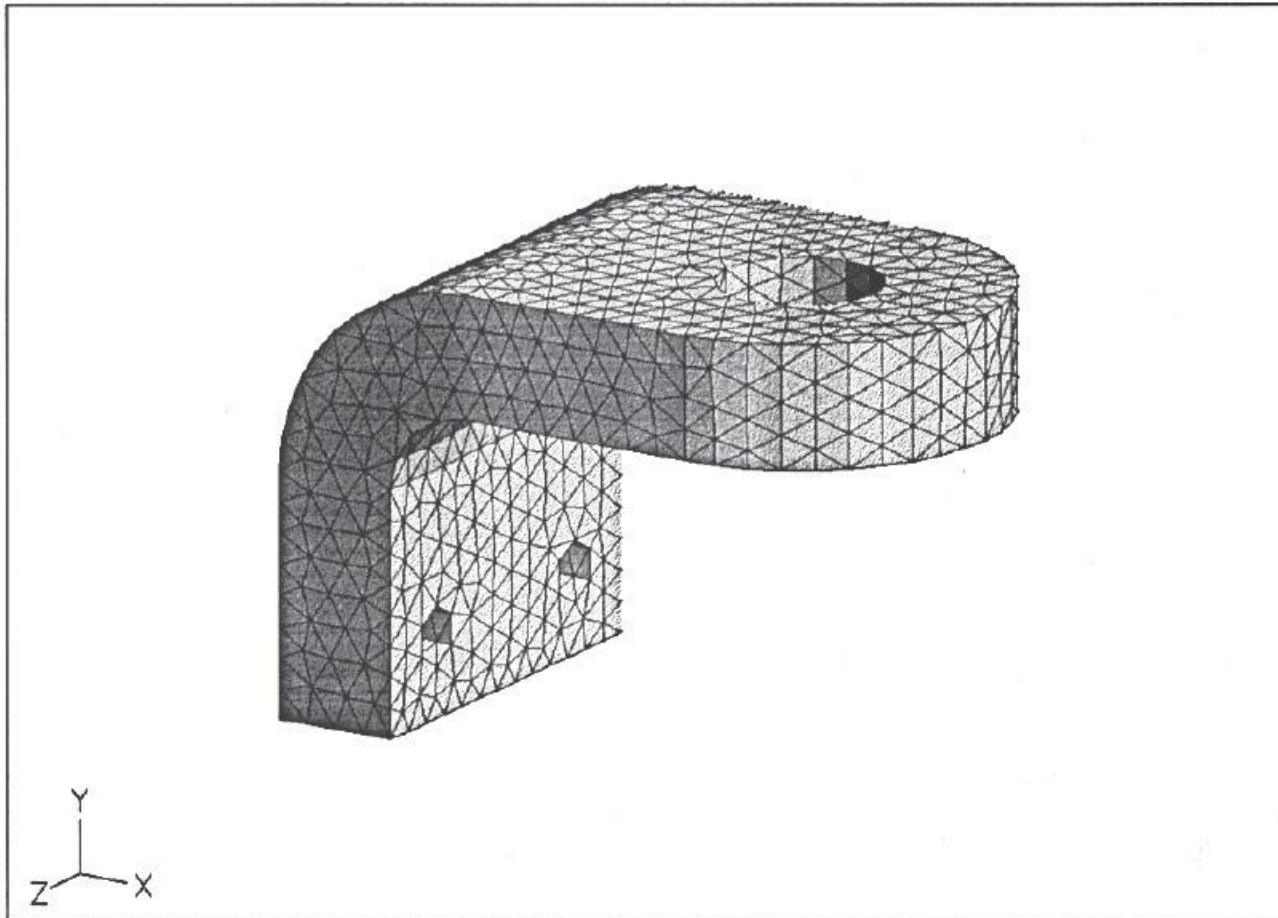
Copyright © 2011 Pearson Education, Inc. publishing as Prentice Hall



**FIGURE 1-5**

A Dimensioned, 3-View Orthographic Drawing Done in a 2-D CAD Drawing Package





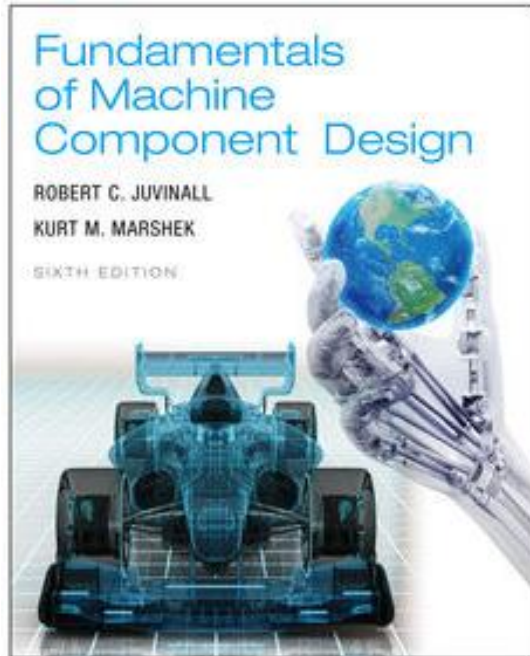
**FIGURE 1-6**

An FEA Mesh Applied to the Solid Model of the Ball Bracket in the CAD System

Copyright © 2011 Pearson Education, Inc. publishing as Prentice Hall

Factor of Safety  $N =$

$$\frac{\text{Material Strength}}{\text{Design Load}}$$



---

# Fundamentals of Machine Component Design

## Sixth Edition

Robert C. Juvinal • Kurt M. Marshek

---

## Chapter 2

### Load Analysis

After certain initial applied loads have been determined or estimated, the basic equations of equilibrium enable loads at other points to be determined. For a nonaccelerating body, these equations can be simply expressed as

$$\Sigma F = 0 \quad \text{and} \quad \Sigma M = 0 \quad (2.1)$$

For an accelerating body they are

$$\Sigma F = ma \quad \text{and} \quad \Sigma M = I\alpha \quad (2.2)$$

These equations apply with respect to each of any three mutually perpendicular axes (commonly designated  $X$ ,  $Y$ , and  $Z$ ), although in many problems forces and moments are present with respect to only one or two of these axes.

The importance of equilibrium analysis as a means of load determination can hardly be overemphasized. The student is urged to study each of the following examples carefully as well as the vectorial approach to equilibrium balance covered in Appendix G.

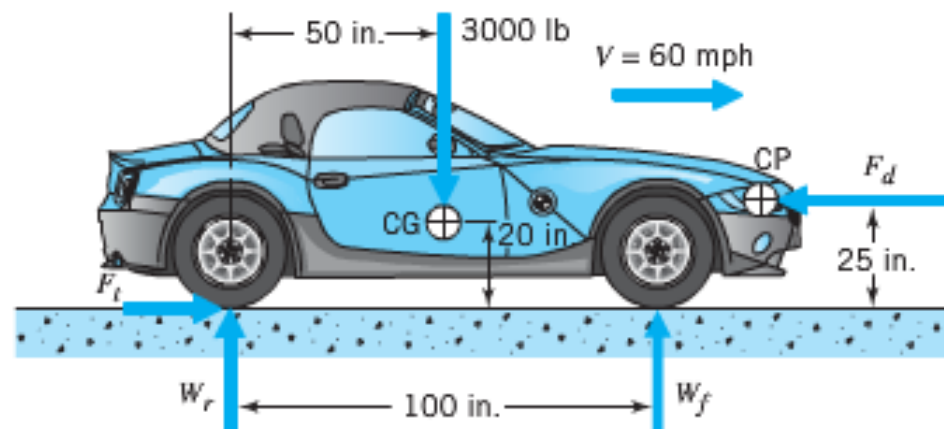
**SAMPLE PROBLEM 2.1****Automobile Traveling Straight Ahead at Constant Speed on Smooth, Level Road**

The 3000-lb (loaded weight) car shown in Figure 2.1 is going 60 mph and at this speed the aerodynamic drag is 16 hp. The center of gravity (CG) and the center of aerodynamic pressure (CP) are located as shown. Determine the ground reaction forces on the front and rear wheels.

**SOLUTION**

**Known:** A car of specified weight travels at a given speed with known drag force.

**Find:** Determine the pavement forces on the tires.

**Schematic and Given Data:****FIGURE 2.1**

Free-body diagram of auto traveling at constant speed.

### Assumptions:

1. The speed is constant.
2. The car has rear-wheel drive.
3. Vertical aerodynamic forces are negligible.
4. The rolling resistance of the tires is negligible.

### Analysis:

1. Power is force times velocity; 1 hp = 33,000 ft·lb/min, and 60 mph = 5280 ft/min; hence,

$$\text{hp} = \frac{\text{drag force (lb)} \cdot \text{velocity (ft/min)}}{33,000}$$

$$16 = \frac{(F_d)(5280)}{33,000}$$

$$F_d = 100 \text{ lb}$$

2. Summation of forces in the direction of motion is zero (no acceleration forces exist at constant velocity); hence, thrust force  $F_t$  is 100 lb in the forward direction. This is the force applied *by* the road surface *to* the tires. (The force applied by the tires to the road is equal but opposite in direction.) This force is divided equally between the rear wheels for the rear-wheel-drive car shown; it could be applied to the front tires for a front-wheel-drive car without altering any other forces.

3. Applying the moment equilibrium equation with respect to moments about an axis passing through the rear tire road contacts, we have

$$\Sigma M = (3000 \text{ lb})(50 \text{ in.}) - (100 \text{ lb})(25 \text{ in.}) - (W_f)(100 \text{ in.}) = 0$$

from which  $W_f = 1475 \text{ lb}$ .

4. Finally, from the summation of vertical forces equals zero, we have

$$\begin{aligned} W_r &= 3000 \text{ lb} - 1475 \text{ lb} \\ &= 1525 \text{ lb} \end{aligned}$$

**Comments:** Before leaving this problem, we note two further points of interest.

1. The weight of the vehicle *when parked* is carried equally by the front and rear wheels—that is,  $W_f = W_r = 1500 \text{ lb}$ . When traveling at 60 mph, forces  $F_d$  and  $F_t$  introduce a front-lifting couple about the lateral axis (any axis perpendicular to the paper in Figure 2.1) of 100 lb times 25 in. This is balanced by an opposing couple created by the added force of 25 lb carried by the rear wheels and the reduced force of 25 lb carried by the front wheels. (Note: This simplified analysis neglects *vertical* aerodynamic forces, which can be important at high speeds; hence, the use of “spoilers” and “wings” on race cars.)
2. The thrust force is not, in general, equal to the weight on the driving wheels times the coefficient of friction, but it *cannot exceed* this value. In this problem the wheels will maintain traction as long as the coefficient of friction is equal to or above the extremely small value of 100 lb/1525 lb, or 0.066.

## SAMPLE PROBLEM 2.2 Automobile Undergoing Acceleration

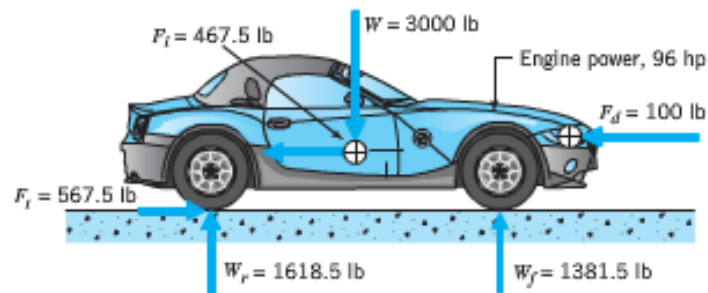
The car in Figure 2.1, traveling 60 mph, is suddenly given full throttle. The corresponding engine power is 96 hp. Estimate the ground reaction forces on the front and rear wheels, and the acceleration of the vehicle.

### SOLUTION

**Known:** A car of specified weight, with known drag force and speed, is given full throttle.

**Find:** Determine the ground forces on the tires and the vehicle acceleration.

**Schematic and Given Data:**



**FIGURE 2.2**  
Free-body diagram  
of auto undergoing  
forward acceleration.

## Chapter 2 ■ Load Analysis

### Assumptions:

1. The rotational inertia effect is equivalent to a car weighing 7 percent more.
2. The rear wheels develop the required traction.



### Assumptions:

1. The rotational inertia effect is equivalent to a car weighing 7 percent more.
2. The rear wheels develop the required traction.

### Analysis:

1. The influence of the *rotating* inertia of the car wheels, engine flywheel, and other rotating members should be considered. When the car accelerates, power is consumed in *angularly* accelerating these members. Detailed calculations typically indicate that in “high” gear the effect of the rotational inertia is to increase the weight of the car by about 7 percent. This means that only 100/107 of the power available for acceleration goes to *linearly* accelerating the car mass.
2. In this problem, 16 hp gives the forward wheel thrust of 100 lb needed to maintain constant speed. With total horsepower increased to 96, 80 hp produces acceleration, of which 80(100/107) or 74.8 hp causes linear acceleration. If 16 hp produces a 100-lb thrust, then, by proportion, 74.8 hp will increase the thrust by 467.5 lb.
3. From Eq. 2.2,

$$a = \frac{F}{m} = \frac{Fg}{W} = \frac{(467.5 \text{ lb})(32.2 \text{ ft/s}^2)}{3000 \text{ lb}} = 5.0 \text{ ft/s}^2$$

4. Figure 2.2 shows the car in equilibrium. The 467.5-lb inertia force acts toward the rear and causes an additional shift of 93.5 lb from the front to the rear wheels (calculation details are left to the reader).

**Comment:** In this problem the wheels will maintain traction as long as the coefficient of friction is equal to or above the value of 567.5/1617, or 0.351.

## SAMPLE PROBLEM 2.6 Three-Force Member

Figure 2.7 shows a bell crank (link 2) that pivots freely with respect to the fixed frame (link 1). A horizontal rod (link 3, not shown) attaches at the top, exerting a force of 40 lb, as shown. (Note the subscript notation:  $F_{32}$  is a force applied by link 3 to link 2.) A rod  $30^\circ$  from horizontal (link 4, not shown) attaches to the bottom, exerting force  $F_{42}$  of unknown magnitude. Determine the magnitude of  $F_{42}$ , and also the direction and magnitude of force  $F_{12}$  (the force applied by fixed frame 1 to link 2 through the pinned connection near the center of the link).

### SOLUTION

**Known:** A bell crank of specified geometry is loaded as shown in Figure 2.7.

**Find:** Determine  $F_{12}$  and the magnitude of  $F_{42}$ .

**Schematic and Given Data:**

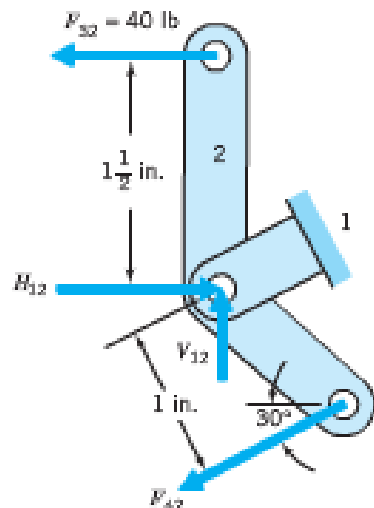


FIGURE 2.7  
Bell crank forces—analytical solution.

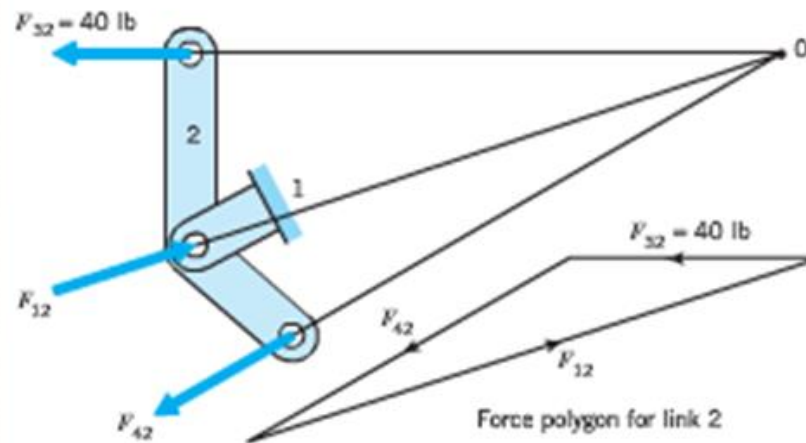


FIGURE 2.8  
Bell crank forces—  
graphical solution.

### Assumptions:

1. The pin joints are frictionless.
2. The bell crank is not accelerating.

### Analysis A (Analytical):

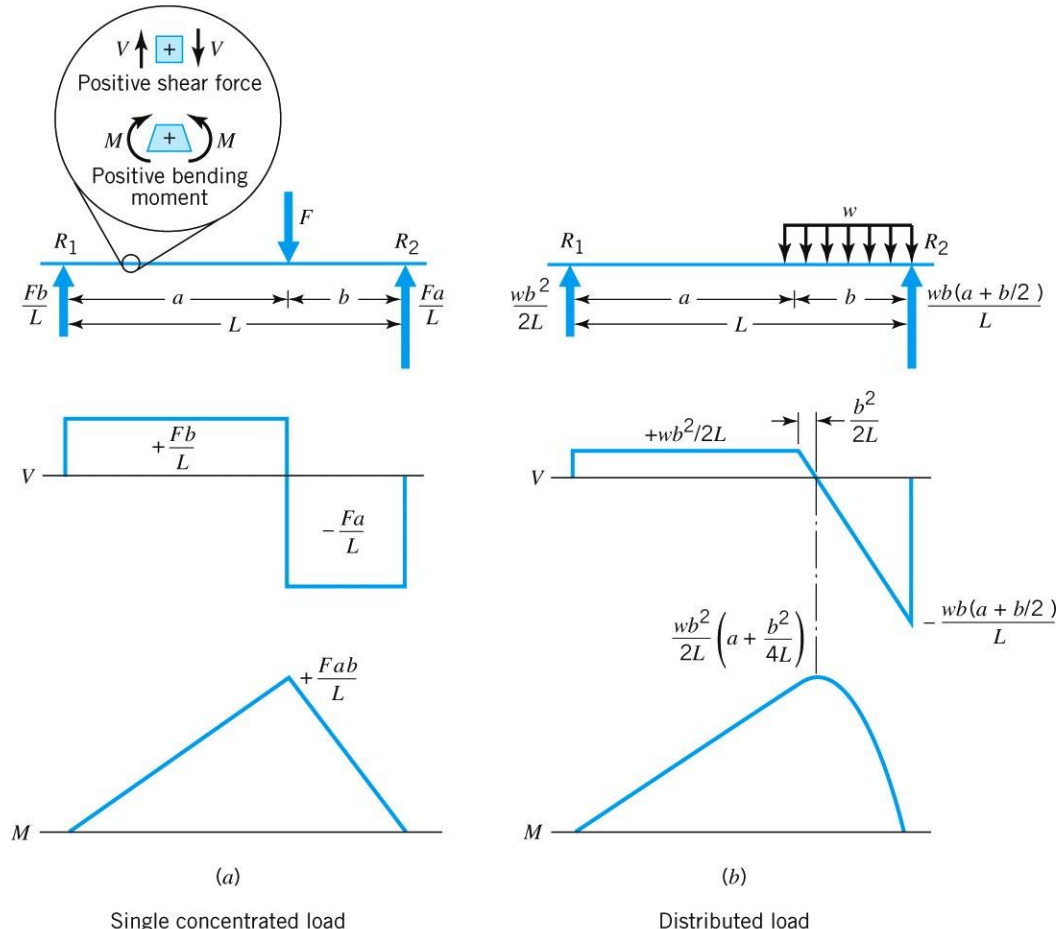
1. Summation of moments about the pivot pin requires that  $F_{42} = 60$  lb (note that  $40 \text{ lb} \times 1\frac{1}{2} \text{ in.} = 60 \text{ lb} \times 1 \text{ in.}$ ).
2. Dividing  $F_{12}$  into horizontal and vertical components, and setting the summation of vertical and horizontal forces acting on link 2 equal to zero yields  $V_{12} = (60 \text{ lb}) (\sin 30^\circ) = 30 \text{ lb}$ ;  $H_{12} = 40 \text{ lb} + (60 \text{ lb}) \cos 30^\circ = 92 \text{ lb}$ . The magnitude of  $F_{12}$  is  $\sqrt{30^2 + 92^2} = 97 \text{ lb}$ ; its direction is upward and to the right at an angle of  $\tan^{-1} 30/92 = 18^\circ$  from horizontal.

### Analysis B (Graphical):

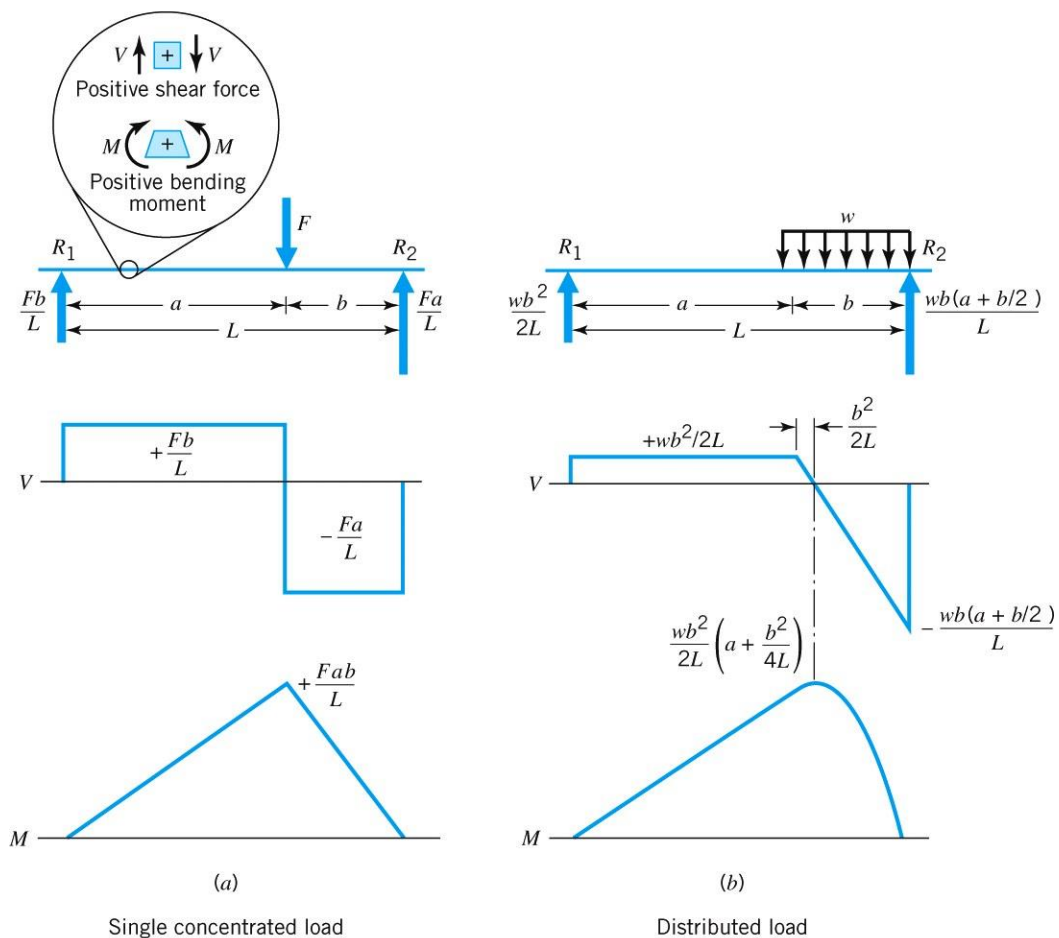
1. For equilibrium, the summation of moments of all forces acting on link 2 must be equal to zero when these moments are taken about *any* point, including point 0, which is the intersection of the two known force lines of action. Since two of the three forces have no moment about point 0, equilibrium requires that the third force also have no moment about 0. This can only be satisfied if the line of action of  $F_{12}$  also passes through 0.
2. We know one force completely, and the other two in direction only. A graphical solution for summation of forces equals zero is provided by the force polygon shown in Figure 2.8. This is constructed by first drawing known force  $F_{32}$  in proper direction and with length representing its 40-lb magnitude to any convenient scale. A line with the direction of  $F_{12}$  is drawn through either end of the vector representing  $F_{32}$ , and a line with the direction of  $F_{42}$  is drawn through the other end of this vector. Magnitudes of the two unknown forces can now be scaled from the polygon. (Note that the same result is obtained if a line of the direction of  $F_{42}$  is drawn through the *tail* of vector  $F_{32}$ , with the direction of  $F_{12}$  being drawn through the *tip* of  $F_{32}$ .)

**Comment:** The analytical solution solved the three equations for equilibrium in a plane for three unknowns. This same solution of simultaneous equations was accomplished graphically in Figure 2.8. An understanding of the graphical procedure adds to our insight into the nature of the force directions and magnitudes necessary for equilibrium of the link. Note that Figure 2.7 and Figure 2.8 show correct free body diagrams if the support link 1 is removed.

“Beam loading” refers to the lateral loading of members that are relatively long in comparison with their cross-sectional dimensions. Torsional or axial loading or both may or may not be involved as well. By way of review, two cases are shown in Figure 2.10. Note that each incorporates three basic diagrams: external loads, internal transverse shear forces ( $V$ ), and internal bending moments ( $M$ ). All expressions for magnitudes are the result of calculations the reader is advised to verify as a review exercise. (Reactions  $R_1$  and  $R_2$  are calculated first, on the basis of  $\sum F = 0$  and  $\sum M = 0$ , with distributed load  $w$  treated as a concentrated load  $wb$  acting in the middle of span  $b$ .)



The sign convention of the shear diagram is arbitrary, but the one used here is recommended: proceed from left to right, following the direction of the applied loads. In this case there are no loads to the left of reaction  $R_1$  and hence no shear forces. At  $R_1$  an upward force of  $Fb/L$  is encountered. Proceeding to the right, there are no loads—hence no *change* in the shear force—until the downward load of  $F$  is reached. At this point the shear diagram drops an amount  $F$ , and so forth. The diagram must come to zero at  $R_2$ , as no loads exist to the right of this reaction.



## SAMPLE PROBLEM 2.8

## Internal Loads in a Transmission Countershaft

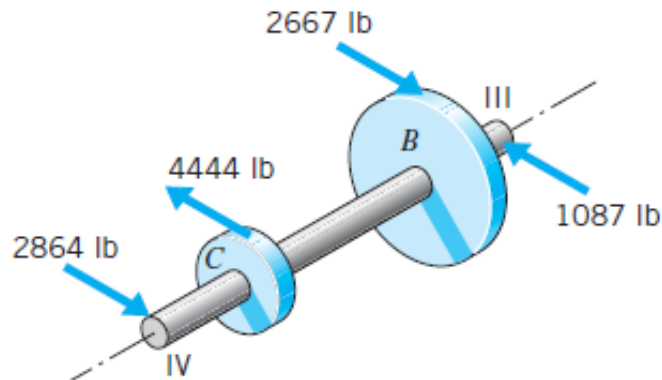
Locate the cross section of the shaft in Figure 2.11 (Figure 2.4c) that is subjected to the greatest loading, and determine the loading at this location.

### SOLUTION

**Known:** A shaft of uniform diameter and given length supports gears located at known positions  $B$  and  $C$  on the shaft.

**Find:** Determine the shaft cross section of greatest loading and the loads at this section.

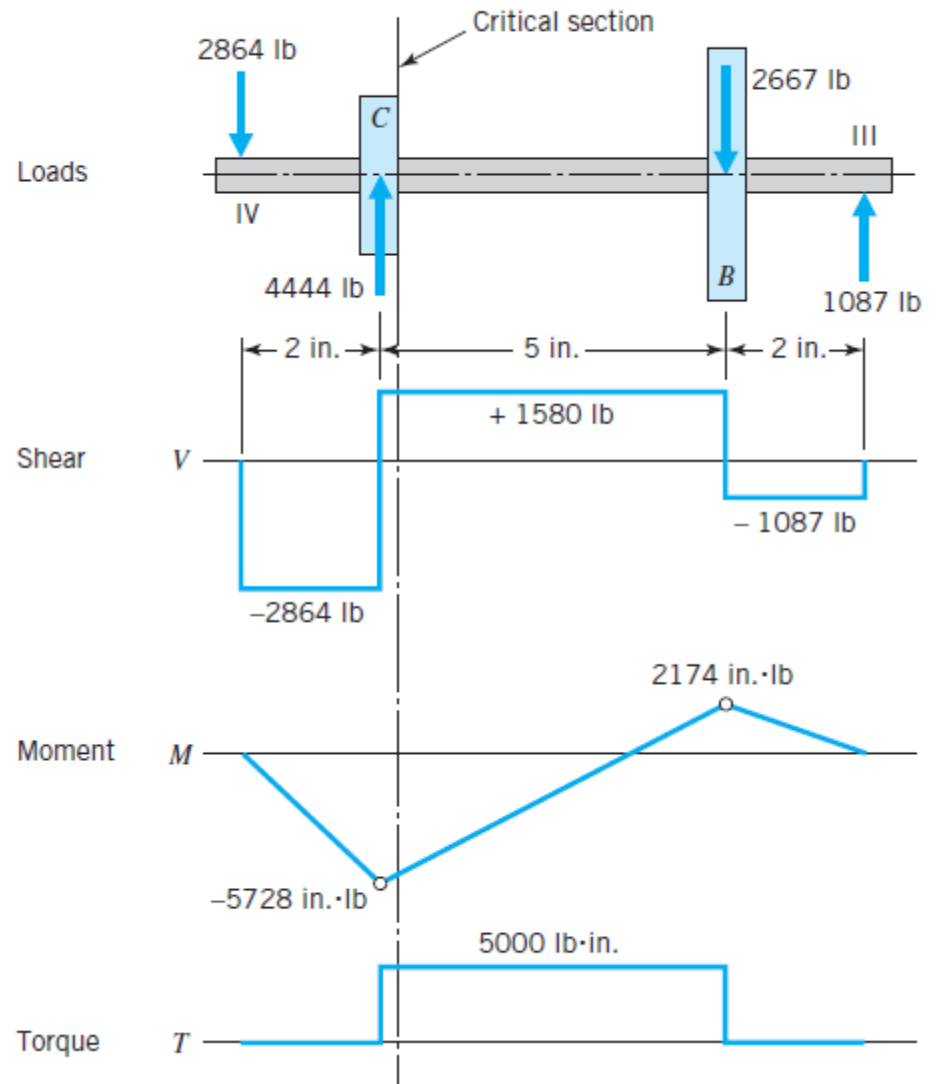
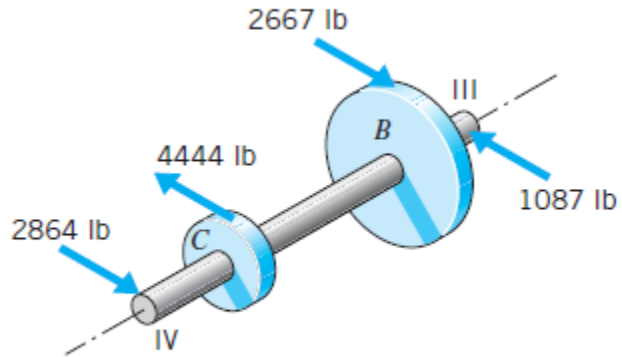
### Schematic and Given Data:



$$\phi \text{ of Gear C} = 2.25''$$
$$\phi \text{ of Gear B} = 3.75''$$

**FIGURE 2.11**  
Countershaft loading,  
and determination of critical  
section.

Schematic and Given Data:



**FIGURE 2.11**  
Countershaft loading,  
and determination of critical  
section.

## Assumptions:

1. The shaft and gears rotate at uniform velocity.
2. Transverse shear stresses are negligible in comparison to bending and torsional shear stresses.

## Analysis:

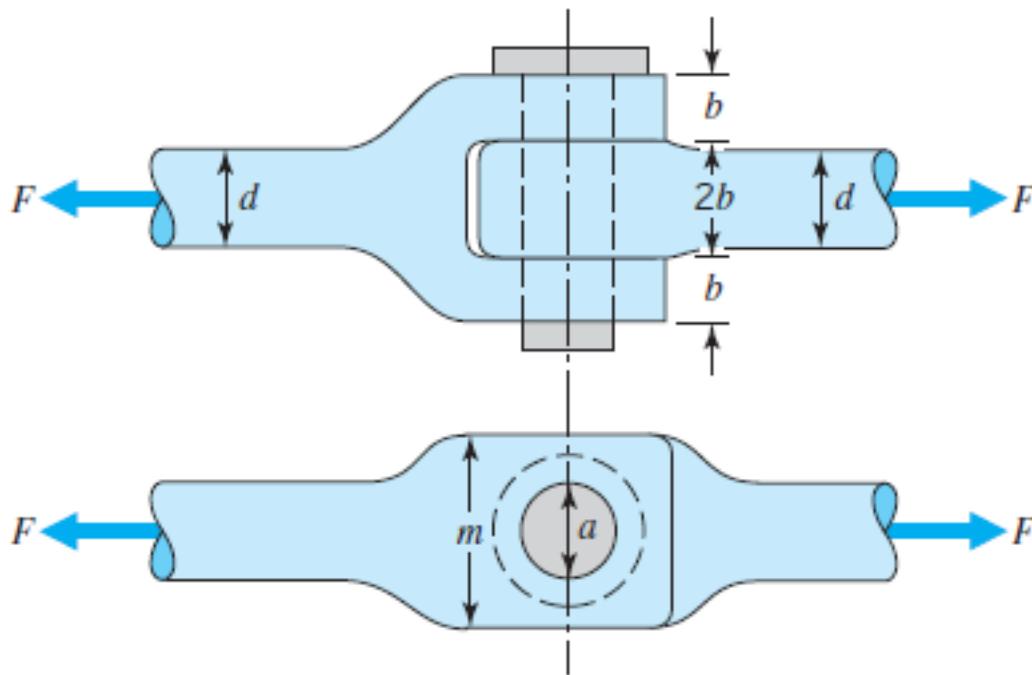
1. Figure 2.11 shows loading, shear, moment, and torque diagrams for this shaft. Note in particular the following.
  - a. The load diagram is in equilibrium—the forces and moments acting in the plane of the paper are balanced.
  - b. The recommended sign convention and the four basic relationships just given in italics are illustrated.
  - c. The sign convention used in the *torque diagram* is arbitrary. Zero torque exists outboard of the gears, for bearing friction would normally be neglected. Torques of  $(4444 \text{ lb})(2.25 \text{ in.}/2)$  and  $(2667 \text{ lb})(3.75 \text{ in.}/2)$  are applied to the shaft at *C* and *B*.
2. The critical location of the shaft is just to the right of gear *C*. Here we have maximum torque together with essentially maximum bending. (The transverse shear force is less than maximum, but except for highly unusual cases involving extremely short shafts, shear loads are unimportant in comparison with bending loads.)



The sections chosen for load determination in the previous examples were, by simple inspection, clearly those subjected to the most critical loading. In more complicated cases, however, several sections may be critical, and their locations less obvious.

In such instances it is often helpful to employ an orderly procedure of following the “lines of force” (approximate paths taken by the force, determined by simple inspection) through the various parts, and noting along the way any sections suspected of being critical. Such a procedure is illustrated in the following example.

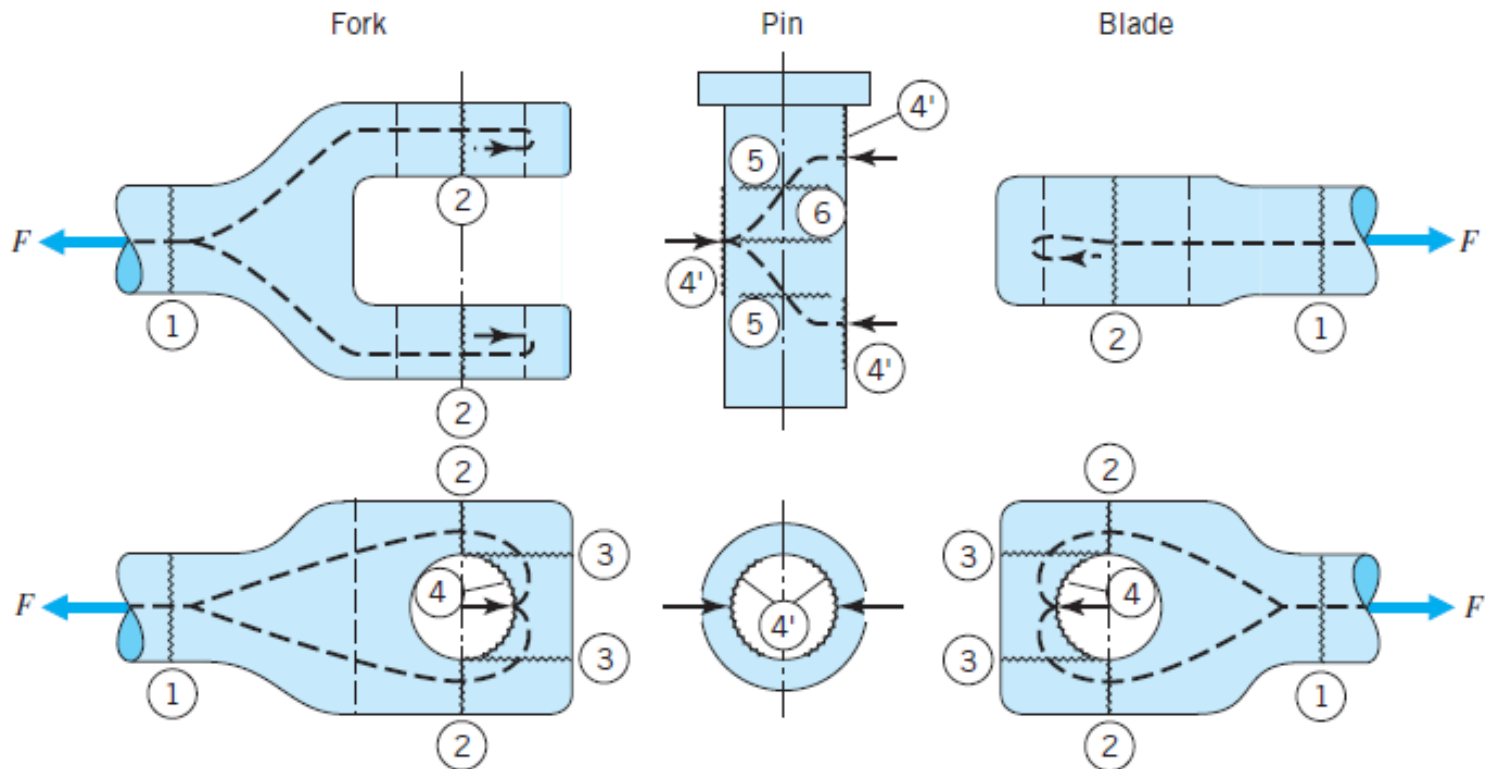
Using the force flow concept, locate the critical sections and surfaces in the members shown in Figure 2.13.



**FIGURE 2.13**  
Yoke connection.

### Assumptions:

1. The weight of the yoke connection can be ignored.
2. The load is divided equally between the two prongs of the fork (the loads and yoke connection are perfectly symmetrical).
3. The load in each prong is divided equally between the portions on each side of the hole.
4. Distributed loads are represented as concentrated loads.
5. The effects of pin, blade, and fork deflections on load distribution are negligible.
6. The pin fits snugly in the fork and blade.

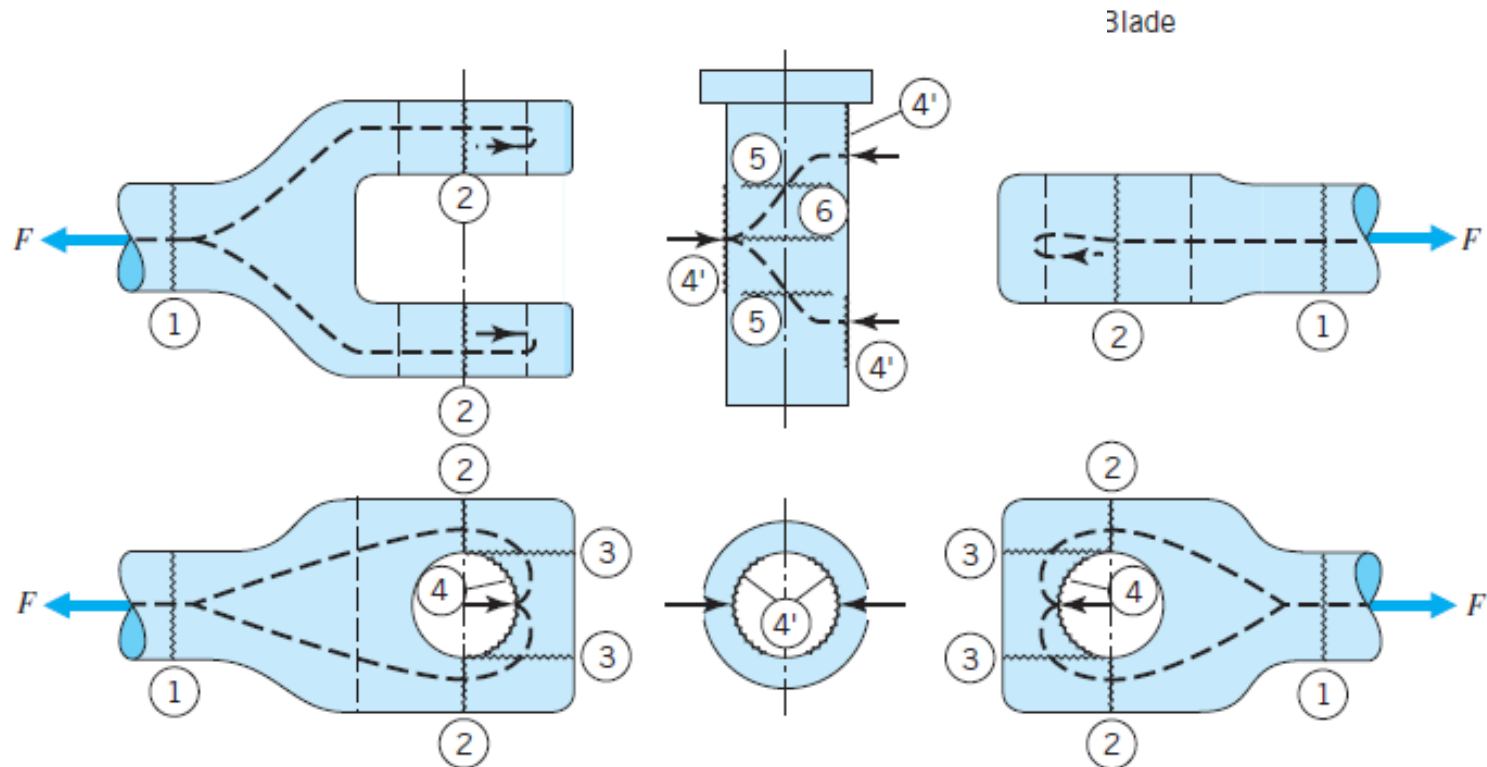


**FIGURE 2.14**

Force flow lines and critical sections in yoke connection.

**Analysis:** A force flow path through each member is indicated by the dashed lines in Figure 2.14. Along this path from left to right, the major critical areas are indicated by the jagged lines and identified by the circled numbers.

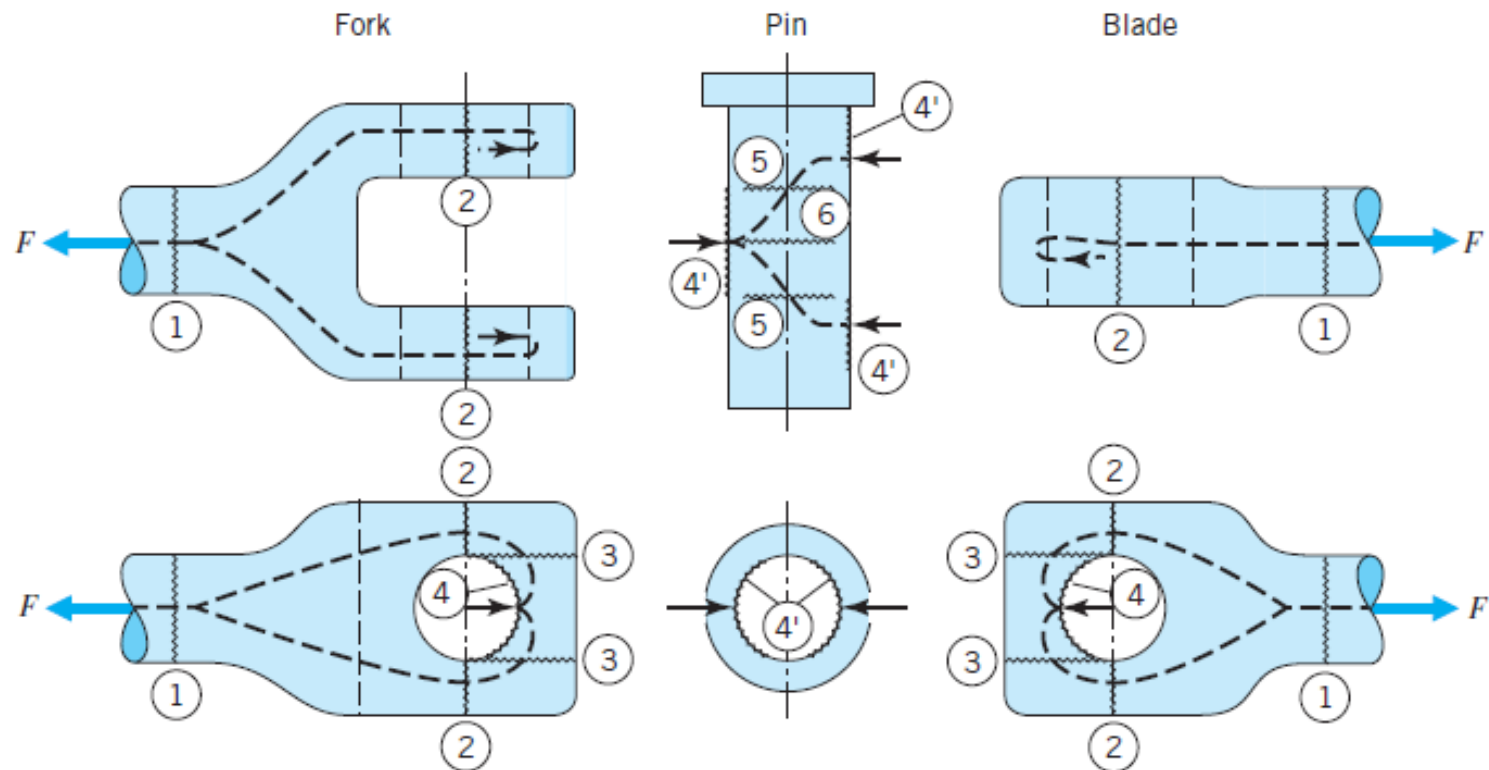
- a. Tensile loading exists at section ① of the fork. If the transition sections have ample material and generous radii, the next critical location is ②, where the force flow encounters a bottleneck because the area is reduced by the holes. Note that with this symmetrical design, force  $F$  is divided into four identical paths, each having an area at location ② of  $\frac{1}{2}(m - a)b$ .
- b. The force flow proceeds on to the next questionable section, which is at ③. Here, the turning of the flow path is associated with shearing stresses tending to “push out” the end segments bounded by jagged lines ③.



**FIGURE 2.14**

Force flow lines and critical sections in yoke connection.

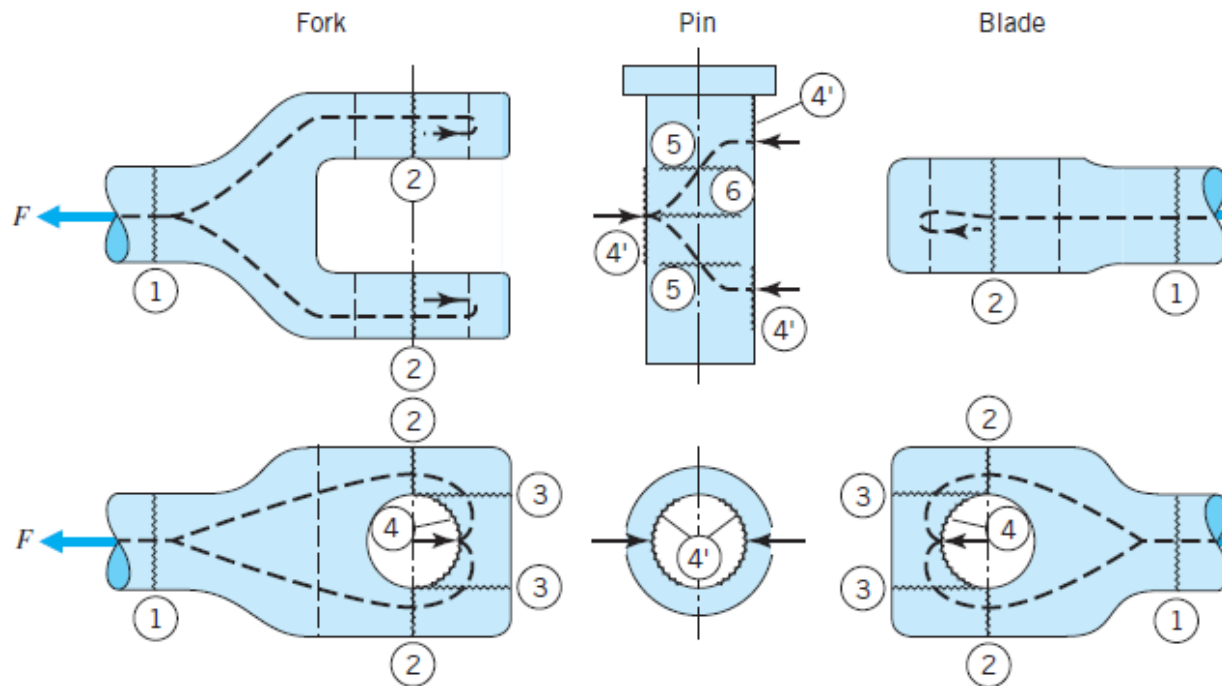
- c. The next critical area is interface ④ and ④', where bearing loading exists between the fork-hole and pin surfaces, respectively. In like manner, equal bearing loads are developed at the interface between the pin and the blade-hole surfaces.
- d. The forces at ④' load the pin as a beam, causing direct shear loading of sections ⑤ (note that the pin is in "double shear" as the two surfaces ⑤ are loaded in parallel, each carrying a shear load of  $F/2$ ). Moreover, the bearing loads produce a maximum bending moment at area ⑥, in the center of the pin.



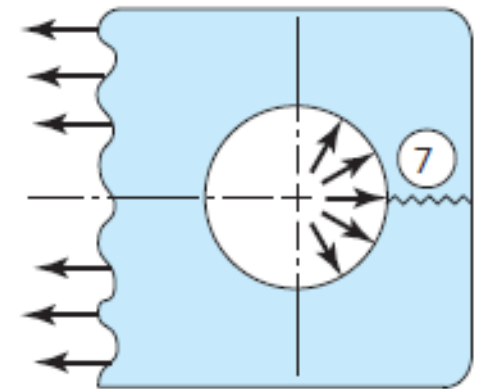
**FIGURE 2.14**

Force flow lines and critical sections in yoke connection.

- e. After the forces emerge from the pin and enter the blade, they flow across critical areas ④, ③, ②, and ①, which correspond directly to the like-numbered sections of the fork.
- f. Although not brought out in the simplified force-flow pattern of Figure 2.14, it should be noted that the bearing loads applied to the surfaces of the holes are not concentrated on the load axis but are, as assumed, *distributed* over these surfaces as shown in Figure 2.15. This gives rise to *hoop tension* (or circumferential tensile loading), tending to cause tensile failure in the section identified as ⑦.



**FIGURE 2.14**  
Force flow lines and critical sections in yoke connection.



**FIGURE 2.15**  
Distributed bearing loading may cause hoop tension failure at 7.