

User Manual

EBPC-3500

Embedded Industrial Computer
Chassis for 3.5" Biscuit SBCs

Trusted ePlatform Services

ADVANTECH

Copyright

The documentation and the software included with this product are copyrighted 2008 by Advantech Co., Ltd. All rights are reserved. Advantech Co., Ltd. reserves the right to make improvements in the products described in this manual at any time without notice. No part of this manual may be reproduced, copied, translated or transmitted in any form or by any means without the prior written permission of Advantech Co., Ltd. Information provided in this manual is intended to be accurate and reliable. However, Advantech Co., Ltd. assumes no responsibility for its use, nor for any infringements of the rights of third parties, which may result from its use.

Acknowledgements

EBPC-3500, PCM-9375, PCM-9380, PCM-9381, PCM-9386 and PCM-9387 are trademarks of Advantech Co., Ltd. All other product names or trademarks are properties of their respective owners.

On-line Technical Support

For technical support and service, please visit our support website at:
<http://www.advantech.com/support>

Safety Instructions

1. Read these safety instructions carefully.
2. Keep this user manual for later reference.
3. Disconnect this equipment from AC outlet before cleaning. Do not use liquid or spray detergents for cleaning.
4. For pluggable equipment, the power outlet shall be installed near the equipment and shall be easily accessible.
5. Keep this equipment away from humidity.
6. Put this equipment on a reliable surface during installation. Dropping it or letting it fall could cause damage.
7. Do not leave this equipment in an environment unconditioned where the storage temperature under 0° C (32° F) or above 40° C (104° F), it may damage the equipment.
8. The openings on the enclosure are for air convection hence protects the equipment from overheating. **DO NOT COVER THE OPENINGS.**
9. Make sure the voltage of the power source is correct before connecting the equipment to the power outlet.
10. Place the power cord such a way that people can not step on it. Do not place anything over the power cord. The voltage and current rating of the cord should be greater than the voltage and current rating marked on the product.
11. All cautions and warnings on the equipment should be noted.
12. If the equipment is not used for long time, disconnect it from the power source to avoid being damaged by transient over-voltage.
13. Never pour any liquid into ventilation openings. This could cause fire or electrical shock.
14. Never open the equipment. For safety reasons, the equipment should be opened only by qualified service personnel.
15. If any of the following situations arises, get the equipment checked by service personnel:
 - a. The power cord or plug is damaged.
 - b. Liquid has penetrated into the equipment.
 - c. The equipment has been exposed to moisture.
 - d. The equipment does not work well or you cannot get it to work according to user manual.
 - e. The equipment has been dropped and damaged.
 - f. The equipment has obvious signs of breakage.
16. **CAUTION:** The computer is provided with a battery-powered real-time clock circuit. There is a danger of explosion if battery is incorrectly replaced. Replace only with same or equivalent type recommended by the manufacture. Discard used batteries according to the manufacturer's instructions.
17. **THE COMPUTER IS PROVIDED WITH CD DRIVES COMPLY WITH APPROPRIATE SAFETY STANDARDS INCLUDING IEC 60825.**

CLASS 1 LASER PRODUCT
KLASSE 1 LASER PRODUKT

18. This device complies with Part 15 of the FCC rules. Operation is subject to the following two conditions:
 - (1) this device may not cause harmful interference, and
 - (2) this device must accept any interference received, including interference that may cause undesired operation.
19. **CAUTION:** Always completely disconnect the power cord from your chassis whenever you work with the hardware. Do not make connections while the power is on. Sensitive electronic components can be damaged by sudden power surges.
20. **CAUTION:** Always ground yourself to remove any static charge before touching the motherboard, backplane, or add-on cards. Modern electronic devices are very sensitive to static electric charges. As a safety precaution, use a grounding wrist strap at all times. Place all electronic components on a static-dissipative surface or in a static-shielded bag when they are not in the chassis.
21. **CAUTION:** Any unverified component could cause unexpected damage. To ensure the correct installation, please always use the components (ex. screws) provided with the accessory box.

Safety Precaution - Static Electricity

Follow these simple precautions to protect yourself from harm and the products from damage.

1. To avoid electrical shock, always disconnect the power from your PC chassis before you work on it. Don't touch any components on the CPU card or other cards while the PC is on.
2. Disconnect power before making any configuration changes. The sudden rush of power as you connect a jumper or install a card may damage sensitive electronic components.

A Message to the Customer

Advantech customer services

Each and every Advantech product is built to the most exacting specifications to ensure reliable performance in the harsh and demanding conditions typical of industrial environments. Whether your new Advantech equipment is destined for the laboratory or the factory floor, you can be assured that your product will provide the reliability and ease of operation for which the name Advantech has come to be known. Your satisfaction is our primary concern. Here is a guide to Advantech's customer services.

To ensure you get the full benefit of our services, please follow the instructions below carefully.

Technical support

We want you to get the best performance possible from your products. If you run into technical difficulties, we are here to help. For the most frequently asked questions, you can easily find answers in your product documentation. These answers are normally a lot more detailed than the ones we can give over the phone.

Please consult this manual first. If you still cannot find the answer, gather all the information or questions that apply to your problem, and with the product close at hand, call your dealer. Our dealers are well trained and ready to give you the support you need to get the most from your Advantech products. In fact, most problems reported are minor and can be easily solved over the phone.

In addition, free technical support is available from Advantech engineers every business day. We are always ready to give advice about application requirements or specific information on the installation and operation of any of our products.

Product Warranty (2 years)

Advantech warrants to you, the original purchaser, that each of its products will be free from defects in materials and workmanship for two years from the date of purchase.

This warranty does not apply to any products which have been repaired or altered by persons other than repair personnel authorized by Advantech, or which have been subject to misuse, abuse, accident or improper installation. Advantech assumes no liability under the terms of this warranty as a consequence of such events.

Because of Advantech's high quality-control standards and rigorous testing, most of our customers never need to use our repair service. If an Advantech product is defective, it will be repaired or replaced at no charge during the warranty period. For out-of-warranty repairs, you will be billed according to the cost of replacement materials, service time and freight. Please consult your dealer for more details.

If you think you have a defective product, follow these steps:

1. Collect all the information about the problem encountered. (For example, CPU speed, Advantech products used, other hardware and software used, etc.) Note anything abnormal and list any onscreen messages you get when the problem occurs.
2. Call your dealer and describe the problem. Please have your manual, product, and any helpful information readily available.
3. If your product is diagnosed as defective, obtain an RMA (return merchandise authorization) number from your dealer. This allows us to process your return more quickly.
4. Carefully pack the defective product, a fully-completed Repair and Replacement Order Card and a photocopy proof of purchase date (such as your sales receipt) in a shippable container. A product returned without proof of the purchase date is not eligible for warranty service.
5. Write the RMA number visibly on the outside of the package and ship it prepaid to your dealer.

Initial Inspection

When you open the carton, please make sure that the following materials have been shipped:

- EBPC-3500 Chassis
- User Manual
- Warranty Card
- Accessory box with a package of screws (for fastening the SBC, 3.5" disk drive, mounting brackets, etc.), 4 pcs of rubber pads, a pair of mounting brackets and a label for the pre-punched I/O ports.

If any of these items are missing or damaged, contact your distributor or sales representative immediately. We have carefully inspected the product mechanically and electrically before shipment. It should be free of marks and scratches and in perfect working order upon receipt. As you unpack the product, check it for signs of shipping damage. (For example, damaged box, scratches, dents, etc.) If it is damaged or it fails to meet the specifications, notify our service department or your local sales representative immediately. Also, please notify the carrier. Retain the shipping carton and packing material for inspection by the carrier. After inspection, we will make arrangements to repair or replace the unit.

Contents

Chapter 1	General Information	1
1.1	Introduction	2
1.2	Specification	3
1.3	Power Supply	3
	Table 1.1: Power supply	3
1.4	Environment Specifications	3
1.5	Dimensions of EBPC-3500	4
	Figure 1.1 Dimension Diagram of EBPC-3500	4
Chapter 2	System Setup	5
2.1	Removing the Chassis Cover	6
	Figure 2.1 Removing the top cover	6
2.2	Installing the Compact Flash or Mini PCI Module	7
	Figure 2.2 Removing the bottom cover to maintain the compact flash or mini PCI module	7
2.3	Installing the 3.5" Biscuit SBC	8
	Figure 2.3 Installing a SBC	8
2.4	Installing a PCI-104 or MIO Module	9
	Figure 2.4 Installing the PCI-104 module	9
	Figure 2.5 Installing a MIO module	9
2.5	Installing the Disk Drive	10
	Figure 2.6 Installing the 2.5" HDD	10
2.6	Attaching the Mounting Brackets	11
	Figure 2.7 Attaching the mounting brackets	11
Chapter 3	I/O Board, Optional Display Module Kit and Cable Connections	13
3.1	I/O Board Layout	14
	Figure 3.1 I/O board layout	14
	Table 3.1: Cable Connections between PCM-9375E and rear I/O Board (for EBPC-3500-75CE)	14
	Table 3.2: Cable Connections between PCM-938X and rear I/O Board (for EBPC-3500-80CE)	16
3.2	Jumper Setting for Rear COM Mode (RS-232/422/485)	18
	Table 3.3: Jumper Setting for COM Mode (RS-232/422/485) on the I/O Board	18
	Figure 3.2 JP1 and JP2 jumper setting for RS-232 mode	18
	Figure 3.3 JP1 and JP2 jumper setting for RS-422/RS-485 mode 19	19
3.3	Optional Display Module Layout	19
	Figure 3.4 Display module layout	19
3.4	Cables Connection between the SBC and the Display Module	20
Chapter 4	Operation	21
4.1	The Front Plate	22
	Figure 4.1 Front plate of EBPC-3500-75CE	22
	Figure 4.2 Front plate of EBPC-3500-80CE	22
4.2	The Rear Plate	22

	Figure 4.3 Rear plate	22
4.3	Replacing the Cooling fan	23
	Figure 4.4 Replacing the system fan	23
4.4	Replacing the Power Board	24
	Figure 4.5 Replacing the power board	24
Appendix A	Exploded Diagram	25
A.1	Exploded Diagram	26
	Figure A.1 Exploded Diagram	26
	Table A.1: Parts List	26
Appendix B	3.5" Biscuit SBC Options	27
B.1	3.5" Biscuit SBC Options	28
	Table B.1: 3.5" Biscuit SBC Options	28

Chapter 1

General Information

This chapter provides general information about the EBPC-3500.

Sections include

- Introduction
- Specifications
- Power supply
- Environment Specifications
- Dimensions Diagram

1.1 Introduction

The EBPC-3500 series is a rugged and compact advanced embedded industrial computer chassis. It is designed specifically for 3.5" biscuit SBCs.

Universal, comprehensive and flexible I/O expansion features

- Built-in is an I/O board that carries common I/O ports out and access from chassis externally
- Easily customized front plate to suit various of 3.5" biscuit SBCs
- Abundant pre-punched I/O ports on the rear plate for various I/O ports demands
- Flexibility to expand the I/O ports by adding a PC/104, PC/104+, PCI-104 or MIO interface modules

Wide range of DC power inputs, ATX supported

- The EBPC-3500 series embedded chassis allows a wide range power inputs from DC 12 V ~ 24 V, it also supports ATX which offers system integrators the flexibility and excellent power management for various embedded application environments.

Compact and robust construction

- Robust and heavy-duty metal cast construction.
- Modular design offers maximum space efficiency and good electromagnetic compatibility.
- A specially cushioned design that absorbs vibration from 2.5" HDD to ensure maximum reliability

Highly scalable performance with Low Power Consumption

- Scalable Low Voltage and Ultra Low Voltage Pentium M class processor system to bring high computing performance with low power consumption.

Optimal integration

- Simple, modular and friendly design
- Quick installation, easy expansion and maintenance
- Product longevity support to secure investment value

1.2 Specification

- **Construction:** Heavy-duty steel
- **Disk Drive Capacity:** One internal 2.5" disk drive bay
- **LED Indicators on front panel:** Single-color LED for Power (green) and HDD activity (red).
- **Front I/O Interfaces:** A mini DIN PS/2 port, a 9-pin D-SUB COM port, a VGA port, a 10/100 LAN port, a USB port (EBPC-3500-80CE only)
- **Rear I/O Interfaces:** Built-in parallel port, DIO port, COM port, LAN port, two USB ports, a Line in jack, a Line out jack and a Mic-in jack. An LVDS and an inverter pre-punched openings reserved for the display module kit. A pre-punched DVI, 2 USB and two 9-pin DSUB openings.
- **Cooling System:** one 40 cm x 40 cm (11.4 CFM) cooling fan
- **Weight:** 1 Kg (2.2lb)
- **Dimensions (W x H x D):** 230 x 70 x 175 mm (9.1" x 2.8" x 6.9")

1.3 Power Supply

The EBPC-3500 accommodates an DC 46 W ATX power board. The detail spec is as below.

Table 1.1: Power supply	
Part Number	9898025700E
Output rating	46 W max.
Power source	12 ~ 24 V _{DC}
Input voltage	12 V _{DC} @ 4.5 A, 16 V _{DC} @ 3.4 A, 19 V _{DC} @ 2.9 A, 24 V _{DC} @ 2.3 A
Output voltage	+5 V _{DC} @ 7 A, +12 V _{DC} @ 0.5 A, +5 V _{SB} @ 1 A
Power input connector	2-pole Phoenix DC power connector

1.4 Environment Specifications

- **Temperature:**
(Operating) 0 to 40° C (32 to 104° F)
(Non-Operating) -20 to 60° C (-4 to 140° F)
- **Relative Humidity:** 0% ~ 95% (non-condensing)
- **Vibration During Operation:**
1Grms (5 ~ 500 Hz)
- **Shock During Operation:**
20G with 11ms duration, half-sine wave

1.5 Dimensions of EBPC-3500

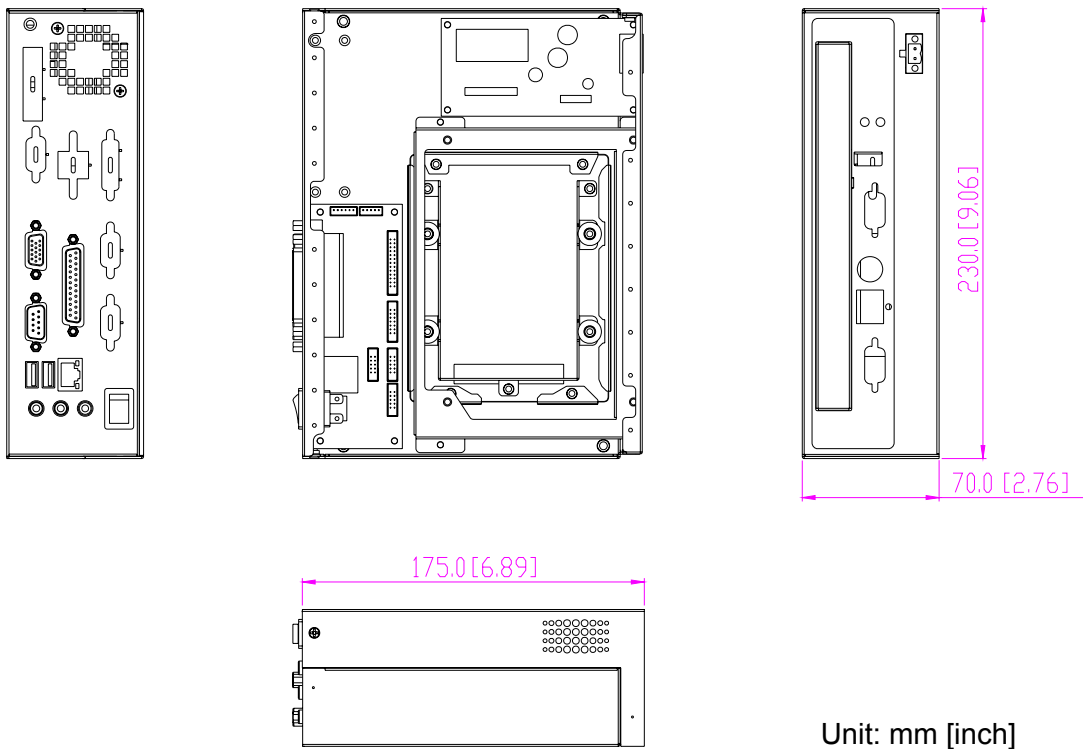

Figure 1.1 Dimension Diagram of EBPC-3500

Chapter 2

System Setup

This chapter introduces the installation process.

Sections include:

- Removing the chassis cover
- Installing the compact flash and mini PCI module
- Installing the 3.5" SBC
- Installing the PCI-104 or MIO module
- Installing the 2.5" disk drive
- Attaching the mounting bracket

The following procedures will instruct you to install a 3.5" SBC, PCI-104 module, MIO module and disk drive into the chassis.

Note! *Use caution when installing or operating the components with the chassis open. Be sure to turn off the power, unplug the power cord and ground yourself by touching the metal chassis before you handle any components inside the machine.*



2.1 Removing the Chassis Cover

To remove the chassis cover, please proceed as below.

1. Loosen two screws on the bottom of the top cover.
2. Loosen two screws on right and left side of the top cover.
3. Pull forwards the top cover and then lift it up. (see Figure 2.1)

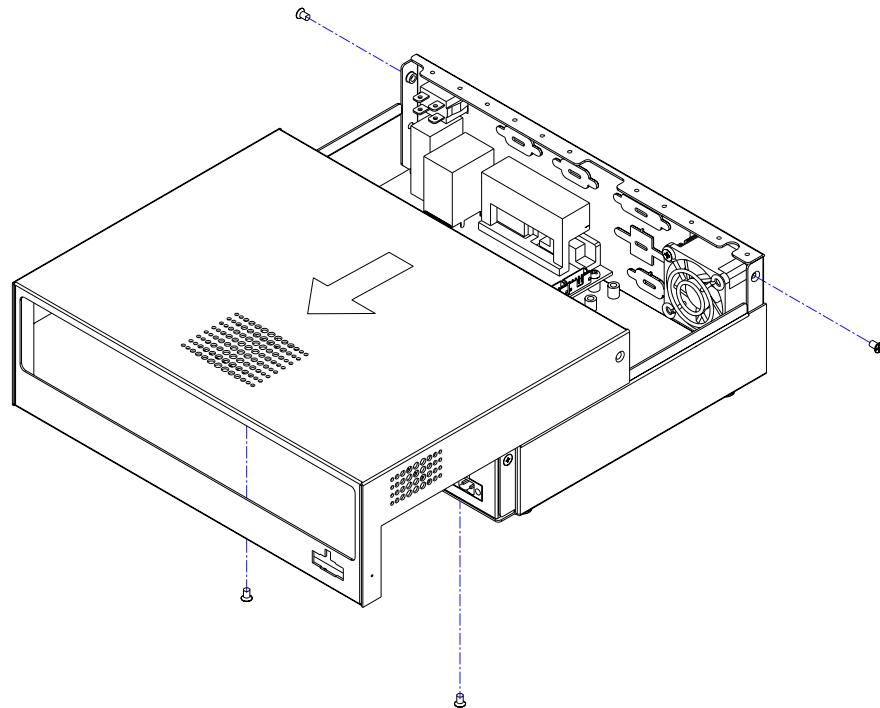

Figure 2.1 Removing the top cover

2.2 Installing the Compact Flash or Mini PCI Module

It's better to insert the compact flash or mini PCI module into the socket on the SBC first if it's necessary. After the SBC has been installed into the chassis, then users need to open the bottom cover of the chassis by loosening the 4 screws to install or replace the compact flash or mini PCI module. (Figure 2.2)

Note! *The compact flash is allocated as Secondary IDE Master.*

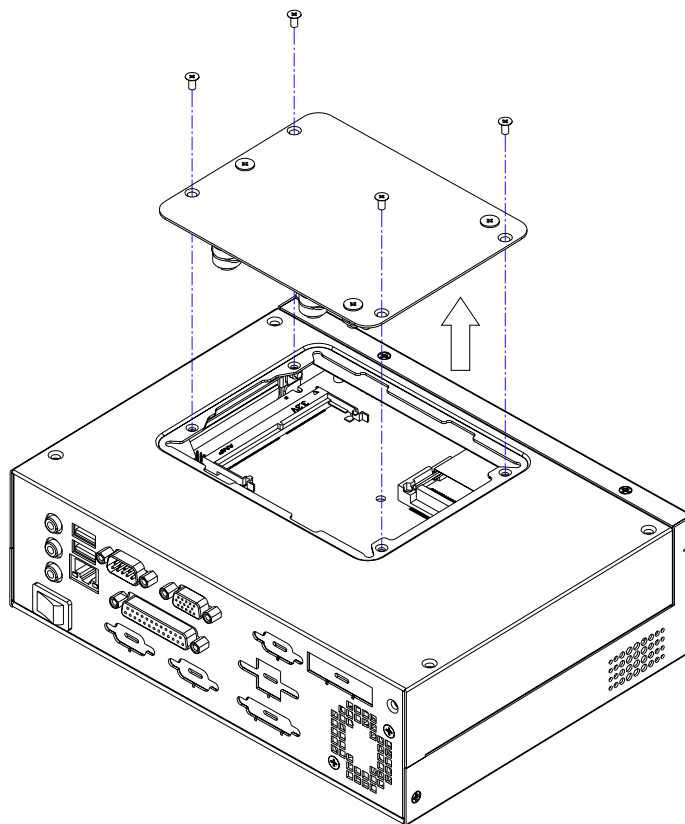

Figure 2.2 Removing the bottom cover to maintain the compact flash or mini PCI module

2.3 Installing the 3.5" Biscuit SBC

The EBPC-3500 supports Advantech PCM-9375E and PCM-938X series (**except PCM-9382**) of 3.5" SBCs. To install the SBC, please proceed as follows: (Figure 2.3)

1. Install the CPU, CPU cooler, RAM, CF card, mini PCI module, etc. on the SBC.
2. Remove the hexangular copper stubs on the VGA port & 9-pin D-SUB port.
3. Fasten the SBC onto the chassis with the screws provided.
4. Find the 4 hexangular copper stubs in the accessory box. Then fasten them onto the VGA port & 9-pin D-SUB port.
5. Connect the cables provided from the front I/O board to the SBC, (see the detail cable connection on Chapter 3)
6. Connect the 12-pin (or 4-pin) power connector from the power board to the SBC.
7. Connect the power LED, HDD LED and power switch wire from the chassis to the SBC.

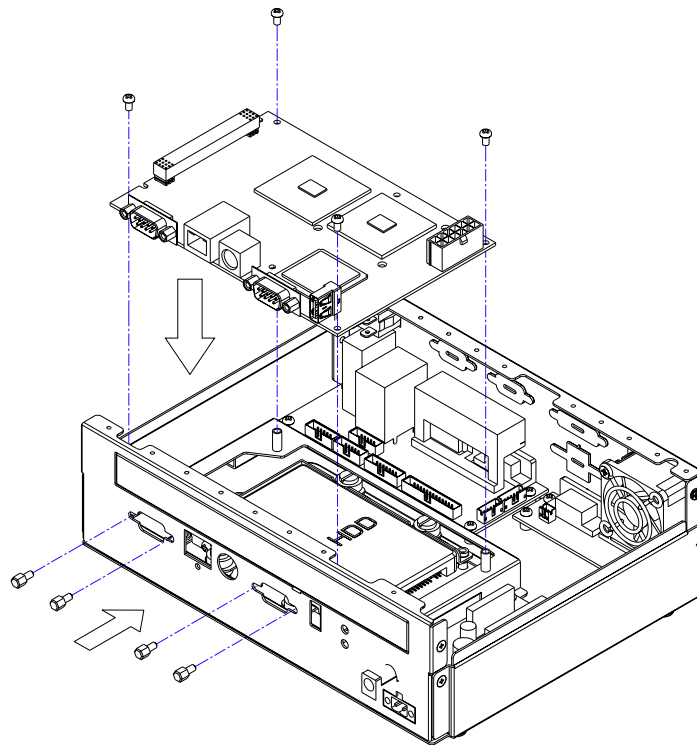

Figure 2.3 Installing a SBC

2.4 Installing a PCI-104 or MIO Module

The EBPC-3500 supports PCI-104 or MIO modules depending on the SBC specification. To install the module, just simply insert the module to the corresponding slot as follows:

Note! Use caution when installing a PCI-104 or MIO module, please note the height limit. It may cause a mechanical obstacle if some components on the PCI-104 or MIO modules are too high.

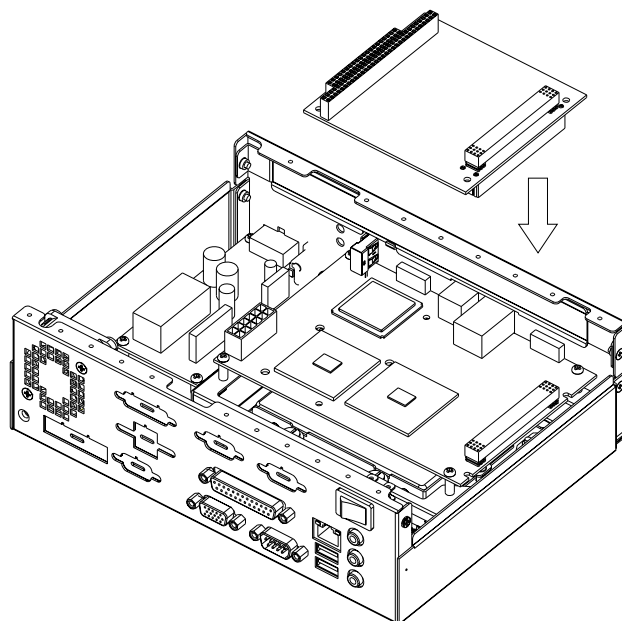

Figure 2.4 Installing the PCI-104 module

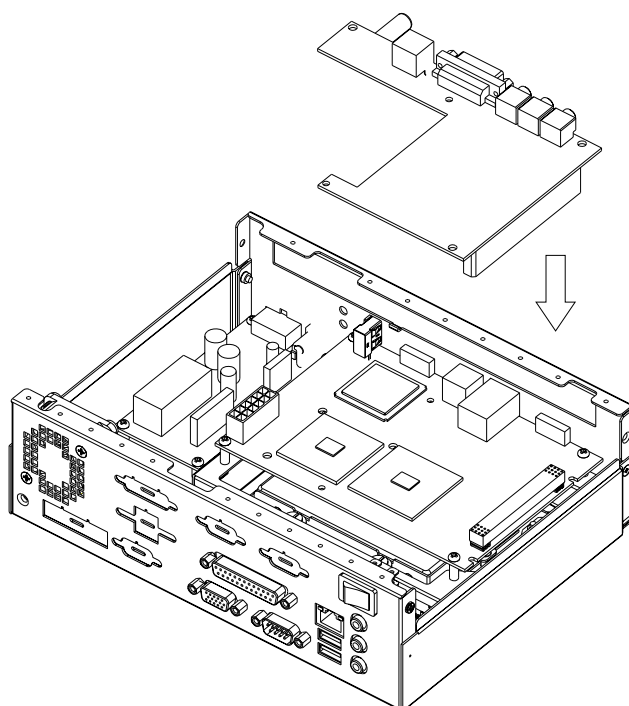

Figure 2.5 Installing a MIO module

2.5 Installing the Disk Drive

The EBPC-3500 comes with a shockproof bracket for an internal 2.5" HDD. Please refer to the following instructions to install the 2.5" hard disk drive.

1. To install the 2.5" internal HDD, remove the bottom cover by releasing the four screws. (see Figure 2.6)
2. The bottom cover is with the HDD bracket mounted. Insert the disk drive into the proper location of the bracket and secure them with the screws provided.
3. Connect the 44-pin IDE cable from the SBC.
4. Return the bottom cover with the 2.5" HDD in the original position and fasten it with the four screws.

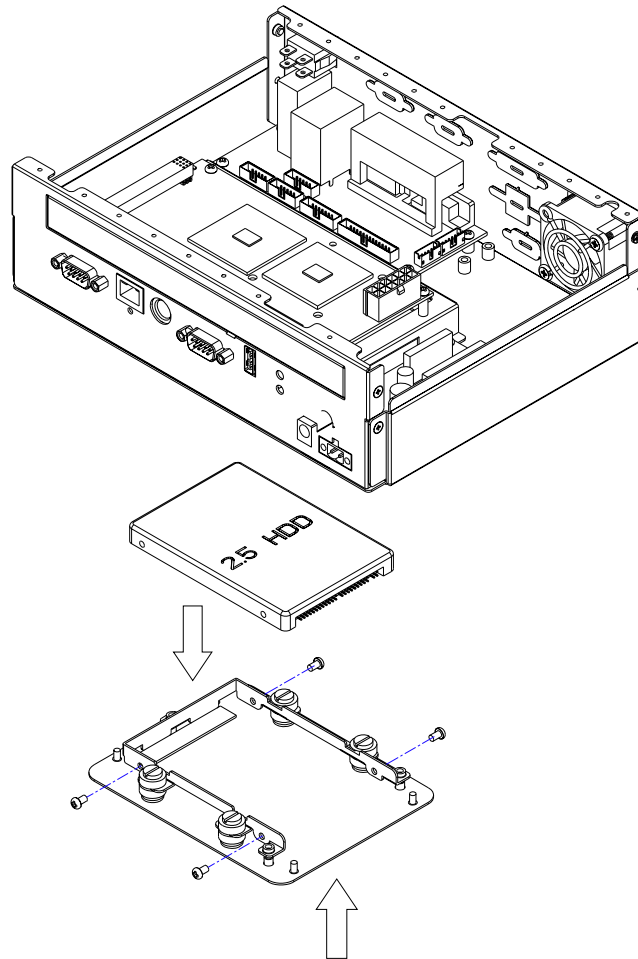

Figure 2.6 Installing the 2.5" HDD

2.6 Attaching the Mounting Brackets

There is a pair of mounting brackets in the accessory box. If you need to install them, please refer to Figure 2.7 to simply fasten them to the bottom-left and bottom-right of the chassis with the four screws provided.

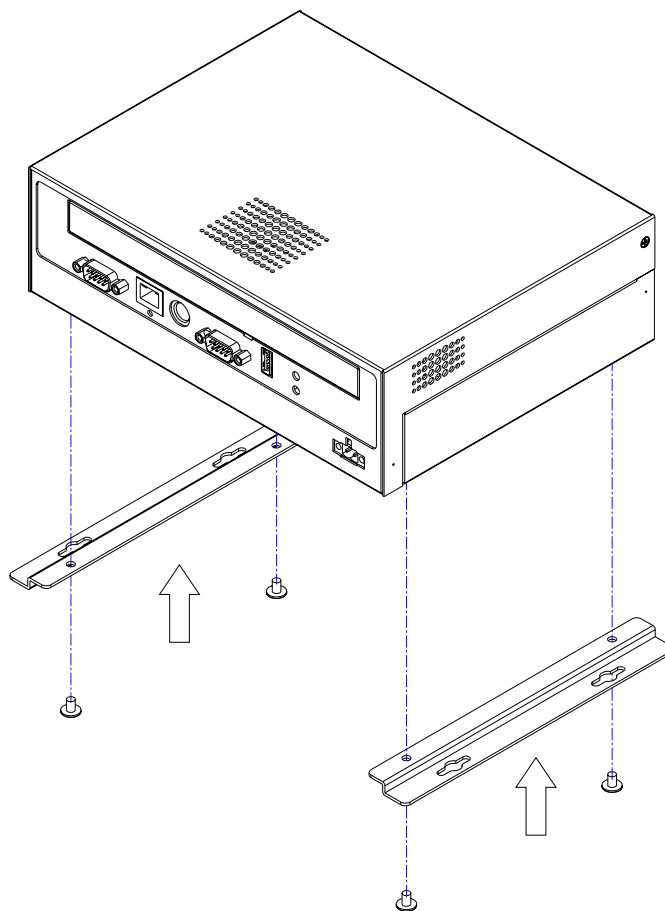

Figure 2.7 Attaching the mounting brackets

Chapter 3

I/O Board, Optional Display Module Kit and Cable Connections

This chapter introduces the I/O board, display module kit and cable connections.

Sections include:

- I/O board layout
- Cable connections between the 3.5" SBC & I/O board
- Optional display module layout
- Cable connections between the SBC & the display module kit

3.1 I/O Board Layout

The layout of the rear I/O board is given below:

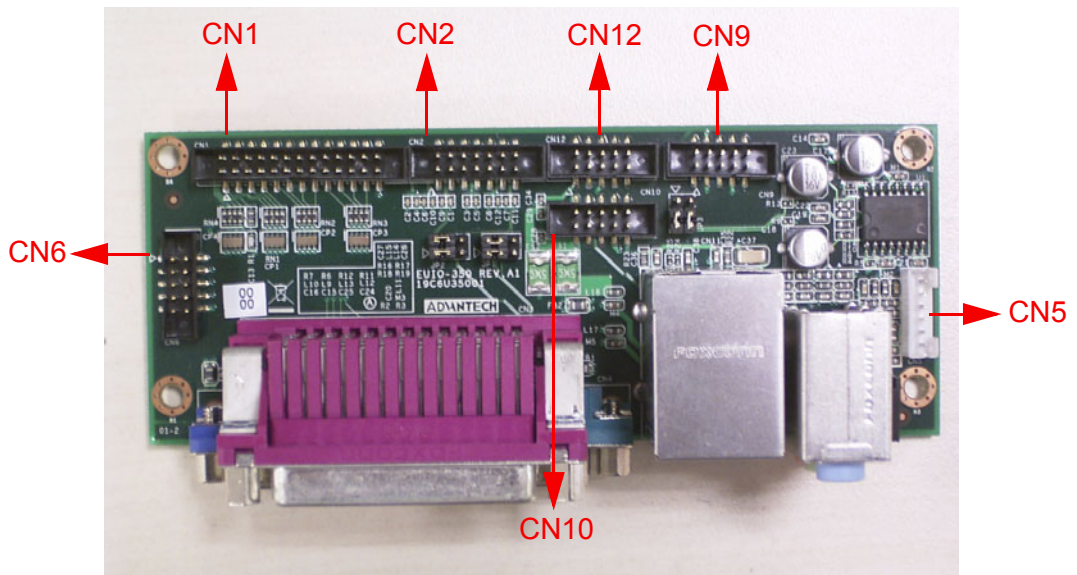

Figure 3.1 I/O board layout

Table 3.1: Cable Connections between PCM-9375E and rear I/O Board (for EBPC-3500-75CE)





Illustration	Part Number	PCM-9375E	Function	Rear I/O Board
	1700001394	-	DC connector converter	-
	1700002172	CN13	USB	Rear plate
	1700002281	CN11	44-pin IDE flat cable	-
	1700002283	CN22	Audio	CN9

Table 3.1: Cable Connections between PCM-9375E and rear I/O Board (for EBPC-3500-75CE)

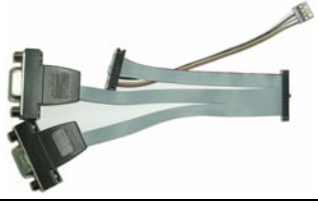





Illustration	Part Number	PCM-9375E	Function	Rear I/O Board
	1700002284	CN24	LAN	CN12
	1700002285	CN16, CN8	COM	CN2, rear plate
	1700008721	CN15	USB	CN10
	1700002286	CN1, CN2	Power cable	CN2 (power board)
	1700002287	CN17	LPT	CN1
	1700002295	CN9	DIO	CN6
	1700007374	CN8	Power switch	Rear plate

Table 3.2: Cable Connections between PCM-938X and rear I/O Board (for EBPC-3500-80CE)











Illustration	Part Number	PCM-938X	Function	Rear I/O Board
	1700001394	-	DC connector converter	-
	1700002275	CN2	Audio	CN9
	1700002277	CN8	COM	CN2
	1700002278	CN13	LPT	CN1
	1700002279	CN7 (PCM-9380 only)	DIO	CN6
	1700002280	CN3	Power cable	CN2 (power board)
	1700002281	CN4	44-pin IDE flat cable	-

Table 3.2: Cable Connections between PCM-938X and rear I/O Board (for EBPC-3500-80CE)

Illustration	Part Number	PCM-938X	Function	Rear I/O Board
	1700008721	CN5	USB	CN10
	1700007132	CN7 (PCM-9387 only)	DIO	CN6
	1700007374	CN16	Power switch	Rear plate
	1700008401	CN10	LED	CN5, rear plate

Note: DIO Pin Definitions:

CN6 (internal)	Pin	CN7 (D-SUB)	CN6 (internal)	Pin	CN7 (D-SUB)
Vcc	1	DIO0	DIO3	9	X
DIO4	2	DIO1	GND	10	X
DIO0	3	DIO2		11	Vcc
DIO5	4	DIO3		12	Vcc
DIO1	5	DIO4		13	GND
DIO6	6	DIO5		14	GND
DIO2	7	DIO6		15	GND
DIO7	8	DIO7			

3.2 Jumper Setting for Rear COM Mode (RS-232/422/485)

The COM port located on the rear plate can be configured to operate in RS-232, RS-422 or RS-485 mode. It is not only set by the SBC but also set by the I/O board. Please refer to the table as below to set the jumper, JP1 and JP2, to meet the mode you need. (Please refer to the setting on the SBC by reading the PCM user manual.)

Table 3.3: Jumper Setting for COM Mode (RS-232/422/485) on the I/O Board

Mode	Setting
RS-232 (default)	JP1 and JP2 (1-2 closed, 4-5 closed)
RS-422	JP1 and JP2 (2-3 closed, 5-6 closed)
RS-485	JP1 and JP2 (2-3 closed, 5-6 closed)

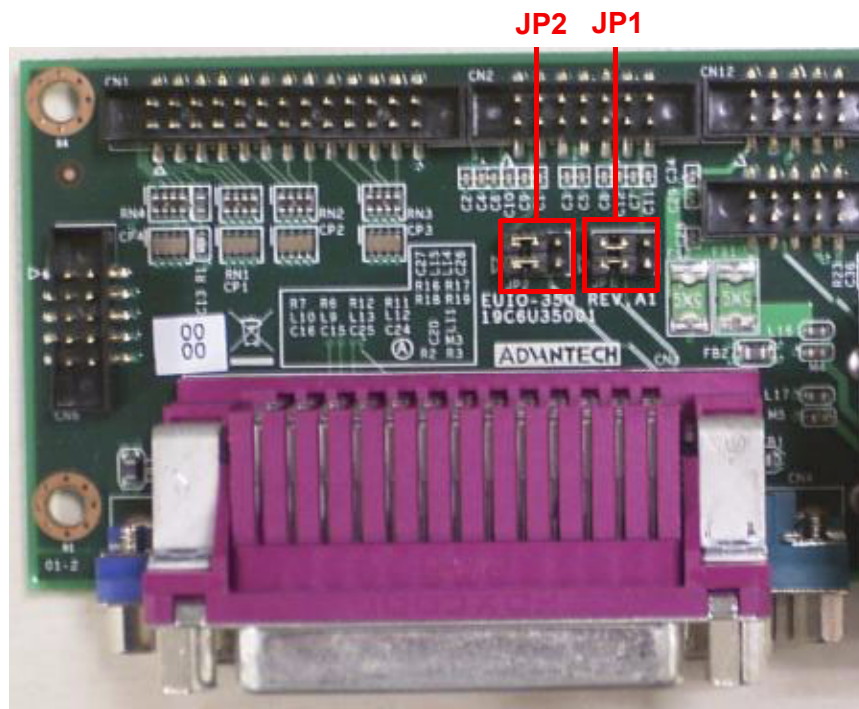

Figure 3.2 JP1 and JP2 jumper setting for RS-232 mode

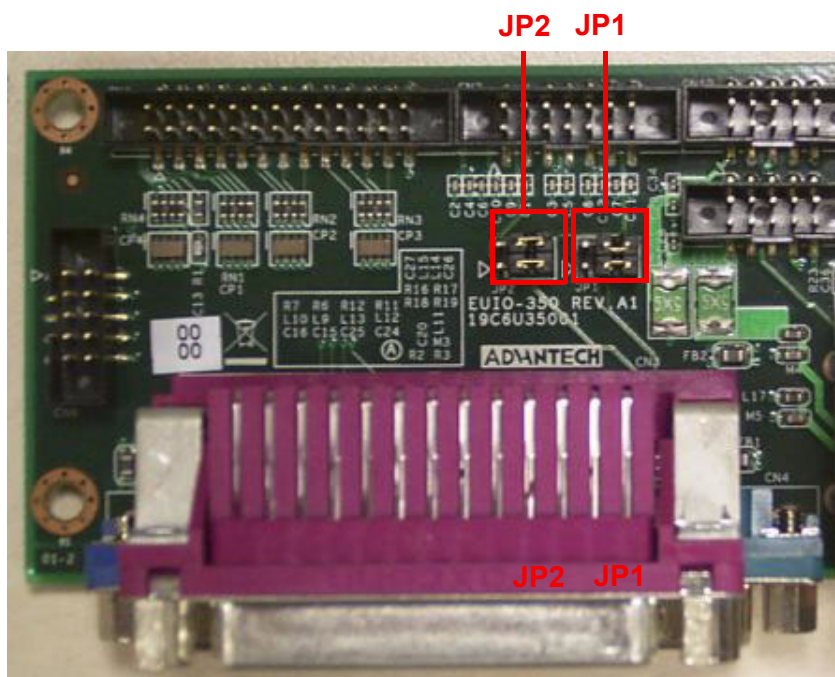

Figure 3.3 JP1 and JP2 jumper setting for RS-422/RS-485 mode

3.3 Optional Display Module Layout

The layout of the optional display module is given below:

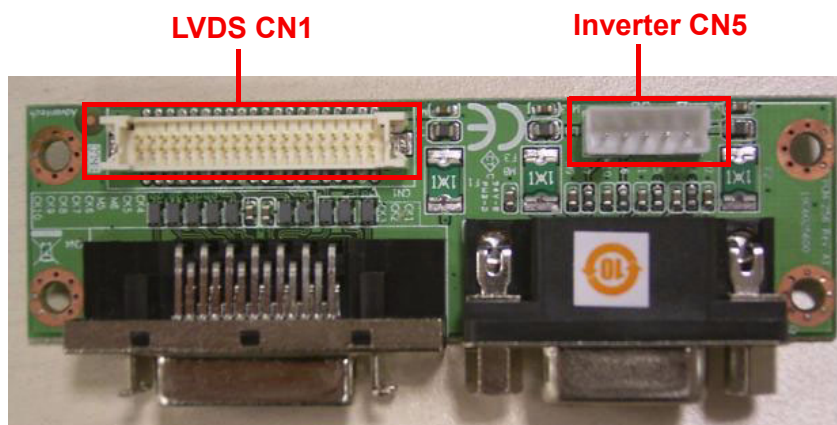







Figure 3.4 Display module layout

3.4 Cables Connection between the SBC and the Display Module

Illustration	Part Number	PCM-9375E PCM-938X	Function	Display Module
	1700000410	CN23 (PCM-9381/ 87 only)	DVI	Rear plate
	1700002289	CN1 (PCM-9380/ 81/86/87)	LVDS	CN1
	1700002297	CN4 (PCM-9375 only)	LVDS	CN1
	1700002288	CN17 (PCM-9380/ 81/86/87)	Inverter	CN5
	1700002282	CN5 (PCM-9375 only)	Inverter	CN5

Chapter 4

Operation

This chapter introduces how to initialize the EBPC-3500.

Sections include:

- The front plate
- The rear plate
- Replacing the cooling fan
- Replacing the power board

4.1 The Front Plate

The front panel features a COM, a LAN, a mini DIN PS/2, a VGA, and a single USB (for EBPC-3500-80CE only) opening. There is also a system reset button and two LEDs. When the system power is on, the POWER LED is always Green. When the HDD LED is blinking Red, it means the HDD is transmitting data. Moreover, it provides a pre-punched area for PCI-104 or MIO module expansion.

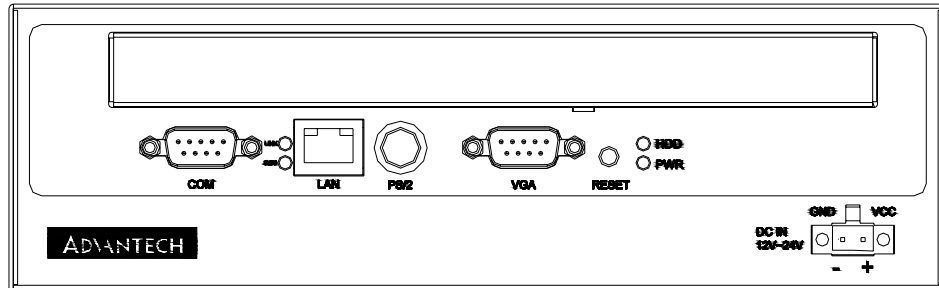

Figure 4.1 Front plate of EBPC-3500-75CE

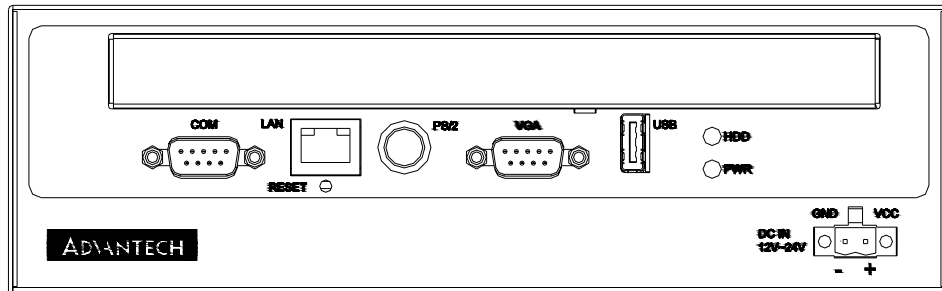

Figure 4.2 Front plate of EBPC-3500-80CE

4.2 The Rear Plate

The rear plate features a Line-in jack, a Line out jack, a Mic-in jack, a LAN port, two USB ports, a 25-pin D-SUB parallel port, a 9-pin D-SUB COM port, and one DIO port. It reserves a LVDS and an Inverter openings for the optional display module kit. It also reserves two 9-pin DSUB, a dual USB and a DVI opening. The momentary ATX power switch is on the rear plate, so it can avoid being touched by accident.

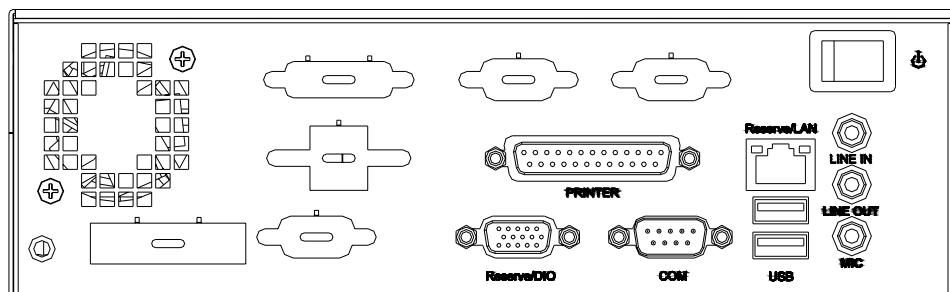

Figure 4.3 Rear plate

4.3 Replacing the Cooling fan

There is a system cooling fan near the rear of the chassis. To replace the cooling fan, please follow the procedures as below.

1. Remove the top cover
2. Unplug the fan power connector.
3. Loosen the two screws on the rear plate and take out the fan module. (see Figure 4.4)
4. Remove the two screws on the fan guard.
5. Fasten the fan guard onto a new fan.
6. Return the fan module with the wire downward to the chassis and fasten it with two screws.
7. Plug in the fan power connector.
8. Replace the top cover and fasten it.

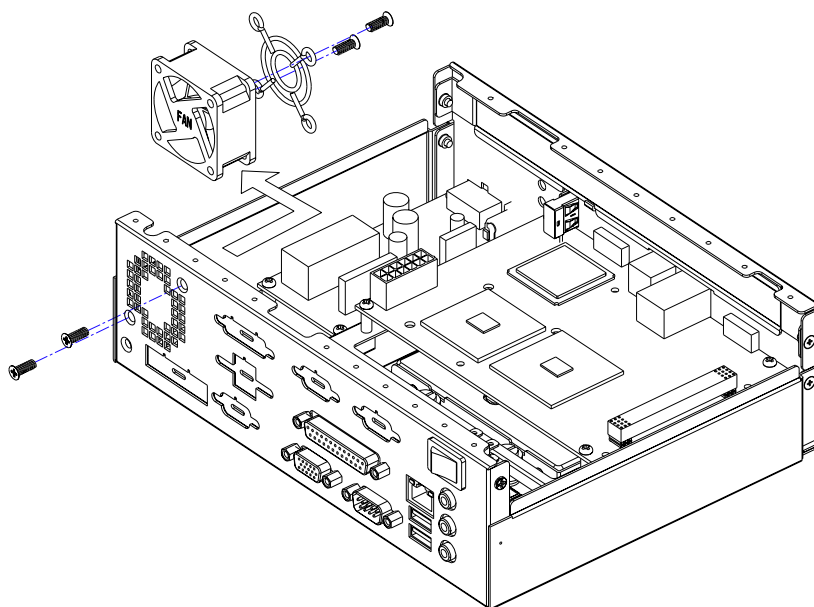

Figure 4.4 Replacing the system fan

4.4 Replacing the Power Board

The EBPC-3500 power is provided by the power board. Connect the EBPC-3500 to a 12~24 V_{DC} power source. The power source can be either from a power adapter or an in-house power source. To replace the power board, proceed as follows:

1. Unplug the DC adapter from the chassis.
2. Remove the top cover.
3. Unplug the 10-pin power connector from the power board.
4. Fasten a new power board onto the chassis.
5. Plug the 10-pin power connector to the power board.
6. Return the top cover and fasten it, finally plug in the DC adapter.

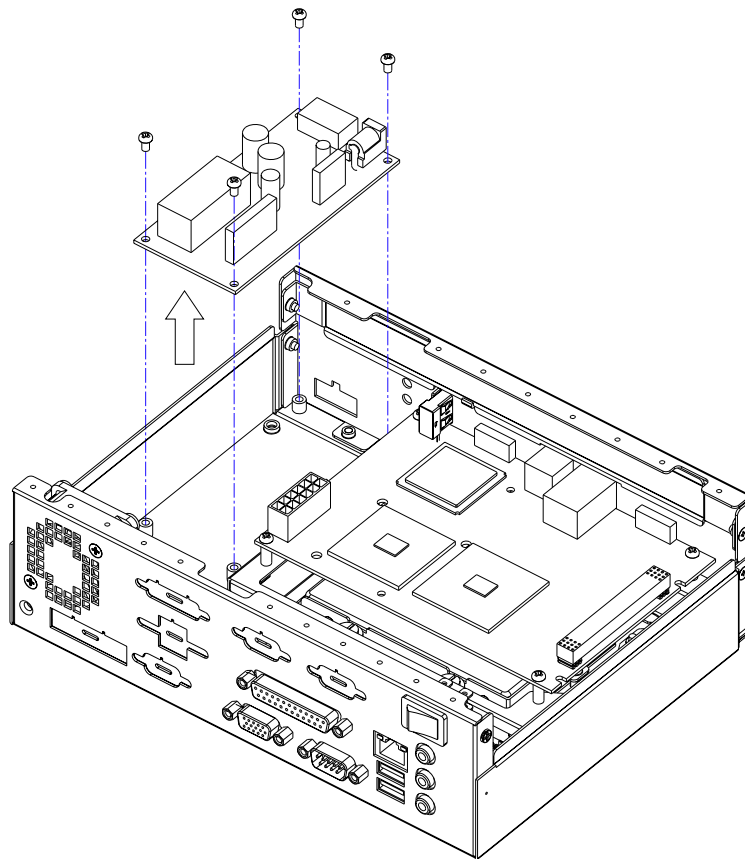

Figure 4.5 Replacing the power board

Appendix **A**

Exploded Diagram

A.1 Exploded Diagram

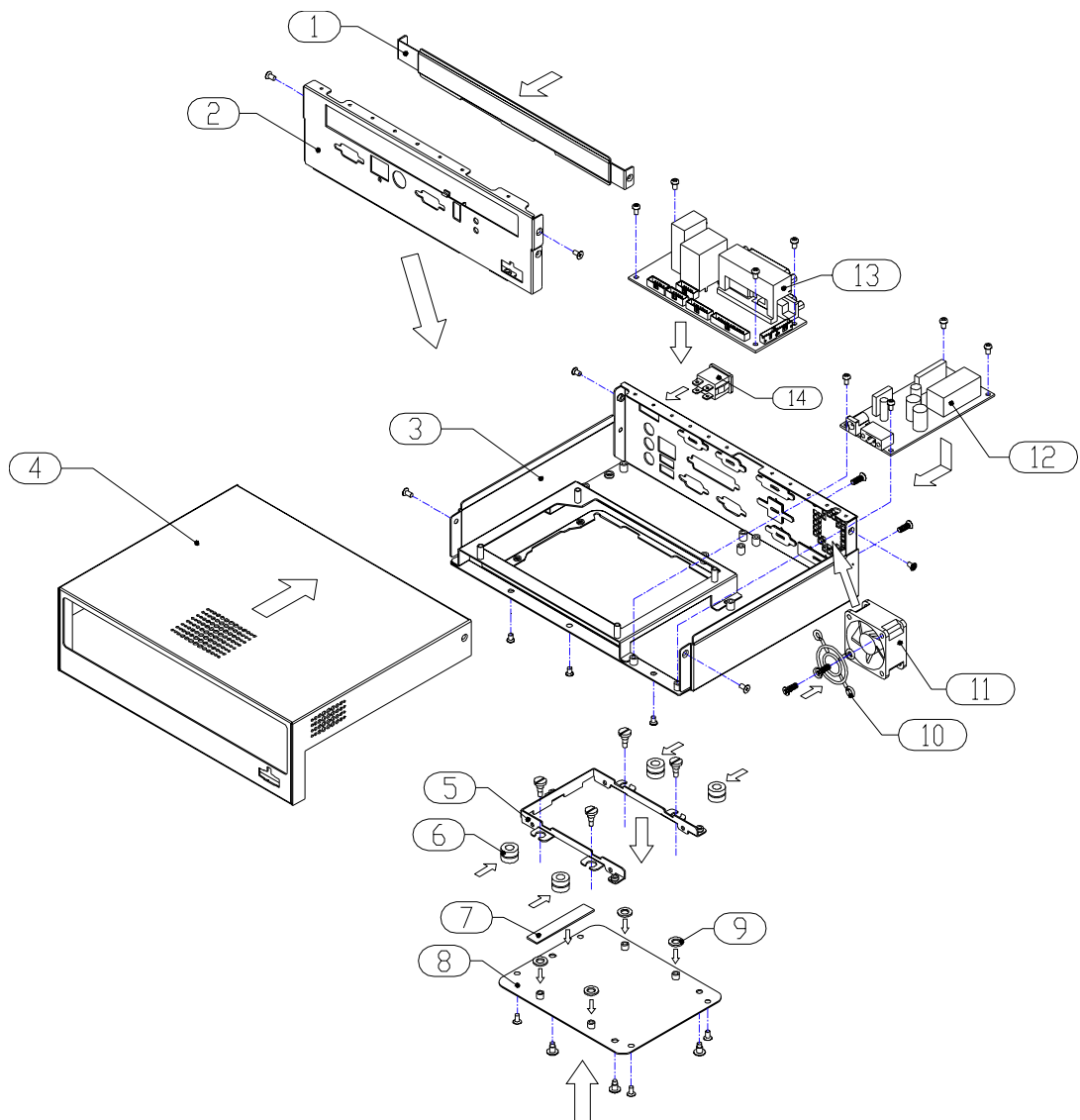

Figure A.1 Exploded Diagram

Table A.1: Parts List

1. MIO module I/O cover	2. FRONT I/O COVER	3. CHASSIS
4. TOP COVER	5. HDD BRACKET	6. RUBBER CUSHION
7. SPRING	8. BOTTOM COVER	9. WASHER
10. FAN GUARD	11. SYSTEM COOLING FAN	12. POWER BOARD
13. I/O BOARD	14. POWER SWITCH	

Appendix **B**

3.5" Biscuit SBC Options

This appendix shows the 3.5" SBC options.

B.1 3.5" Biscuit SBC Options

EBPC-3500 supports a variety of Advantech 3.5" biscuit SBCs as below. Users can contact a local sales representative for detailed information.

Table B.1: 3.5" Biscuit SBC Options

Model Name	Slot			
	CF	PCI-104	PC/104	MIO
PCM-9375E	1	-	V	-
PCM-9380	1	-	-	V
PCM-9381	1	V	-	-
PCM-9386	1	-	-	V
PCM-9387	1	V	-	-

Trusted ePlatform Services

ADVANTECH

www.advantech.com

Please verify specifications before quoting. This guide is intended for reference purposes only.

All product specifications are subject to change without notice.

No part of this publication may be reproduced in any form or by any means, electronic, photocopying, recording or otherwise, without prior written permission of the publisher.

All brand and product names are trademarks or registered trademarks of their respective companies.

© Advantech Co., Ltd. 2008