

Kinetic Relations and the Propagation of Phase Boundaries in Solids

ROHAN ABEYARATNE & JAMES K. KNOWLES

Communicated by C. DAFERMOS

Abstract

This paper treats the dynamics of phase transformations in elastic bars. The specific issue studied is the compatibility of the field equations and jump conditions of the one-dimensional theory of such bars with two additional constitutive requirements: a *kinetic relation* controlling the rate at which the phase transition takes place and a *nucleation criterion* for the initiation of the phase transition. A special elastic material with a piecewise-linear, non-monotonic stress-strain relation is considered, and the Riemann problem for this material is analyzed. For a large class of initial data, it is found that the kinetic relation and the nucleation criterion together single out a unique solution to this problem from among the infinitely many solutions that satisfy the entropy jump condition at all strain discontinuities.

1. Introduction

The continuum modeling of phase transformations in solids has recently attracted much analytical attention. Purely mechanical equilibrium problems involving coexistent phases in elastic materials have been studied, for example, by ABEYARATNE (1981, 1983), ERICKSEN (1975), GURTIN (1983), JAMES (1979, 1981, 1986), and SILLING (1988, 1989). In these analyses, the equilibrium states of principal interest were those that were stable in the sense that they minimized absolutely the appropriate energy functional.

Quasi-static motions of elastic solids that involve both stable and metastable equilibrium states have been studied by ABEYARATNE & KNOWLES (1987a, b), (1988a, b), (1989), who observe that additional constitutive information is needed if the associated macroscopic response of the body is to be determinate. In the latter three papers in particular, the supplementary constitutive postulate was taken to be one that governs the initiation and evolution of the phase transformation. The importance of an *initiation* or *nucleation criterion*, together with a suitable

kinetic relation, in the description of phase transformations is emphasized in the literature in materials science; see, for example, Chapters 10 and 11 of CHRISTIAN (1975) or Chapters 13 and 17 of RALLS, COURTNEY & WULFF (1976).

The detailed implications of a kinetic relation and an initiation criterion were investigated by ABEYARATNE & KNOWLES (1988a), who considered quasi-static motions involving phase transformations in bars under tension on the basis of a one-dimensional model. Because the elastic potential in the model is non-convex, stress is a non-monotonic function of strain, so that a given tensile force applied to the bar may result in any one of infinitely many equilibrium states involving a mixture of phases. It is this lack of uniqueness of the underlying equilibrium problem that makes room for the kinetic relation in the mathematical theory. Moreover, a single relation controlling the kinetics of the phase transformation, accompanied by an initiation criterion, is found to be sufficient to overcome this breakdown in uniqueness and to lead to a determinate relationship between the histories of the force applied to the bar and its overall elongation during any quasi-static process. In fact, under reasonable assumptions on the kinetic relation, the hysteretic macroscopic response predicted by the analysis is qualitatively similar to that observed in experiments on martensitic transformations such as those reported by KRISHNAN & BROWN (1973) or GRUJICIC, OLSON & OWEN (1985b).

If the kinetic relation and the initiation criterion are indeed a part of the constitutive description of the material, they must apply not only during quasi-static motions, but also when inertial effects are included. Motivated in part by this concern, we investigate here whether these additional constitutive postulates can be accommodated by the system of conservation laws appropriate to the simplest one-dimensional theory of the *dynamics* of bars.

Further motivation for the inclusion of inertial effects in a continuum model of phase transformations arises from experiments. According to GRUJICIC, OLSON & OWEN (1985a), reported measurements of phase boundary velocities vary widely, from values small enough to permit direct optical observation to values approaching the speed of shear waves in the parent phase of the material; see also BUNSHAK & MEHL (1952).

The dynamical aspects of phase transformations have been studied by a number of authors in recent years, beginning with the paper of JAMES (1980), who pointed out several important issues concerning phase transitions in elastic bars. A sample of the more recent literature, often concerned with the van der Waals fluid, may be found in HATTORI (1986a, b), PENCE (1986), SHEARER (1986, 1988), ŠILHAVÝ (1988), SLEMROD (1983, 1989), and TRUSKINOVSKY (1985, 1987).

In the classical dynamics of an ideal gas in one dimension, the extent of the lack of uniqueness of weak solutions to the Cauchy problem for the corresponding system of conservation laws is such that the imposition of the entropy inequality at shock fronts is sufficient to rule out all but one solution. The mathematical theory of conservation laws and shock waves, with gas dynamics serving as a prototype, has developed a large literature, the early portion of which is summarized by LAX (1973); a discussion of more recent work is included in the article by DAFERMOS (1983). A uniqueness theorem appropriate to the Cauchy problem for quasi-linear systems of the kind arising in gas dynamics was apparently first

proved by OLEINIK (1957). Her result is also applicable to the simplest model of longitudinal waves in a one-dimensional bar, provided the material is such that stress is a monotonically increasing function of strain that is *either* strictly convex or strictly concave. If the material of the bar is capable of undergoing phase transformations, the stress-strain relation in general has neither the monotonicity nor the convexity property required in OLEINIK's theorem. For these latter materials, one can show that the imposition of the entropy inequality at curves in space-time bearing jumps in strain or particle velocity is no longer sufficient to guarantee uniqueness for the Cauchy problem. A number of authors have proposed a variety of stronger "admissibility conditions" intended to generalize the entropy inequality and designed to select physically appropriate solutions in the case of conservation laws that are either non-strictly hyperbolic or of mixed type. Thus DAFERMOS (1973), for example, has proposed a *maximum entropy rate* admissibility condition. The implications of this condition have been studied in the setting of elastic bars by JAMES (1980) and for the van der Waals fluid by HATTORI (1986a, b); for further discussion, see DAFERMOS (1989). SLEMROD (1983) derives admissibility conditions by embedding the theory of the van der Waals fluid in a higher order theory that includes the effects of both viscosity and capillarity; such an embedding is also utilized by TRUSKINOVSKY (1985). Implications of SLEMROD's notion of admissibility have been studied by SHEARER (1986, 1988), who has also investigated other possible conditions of admissibility for conservation laws of mixed type; see SHEARER (1982).

The approach to be taken in the present paper is entirely different from those cited above. We shall investigate whether the entropy inequality at strain discontinuities and the kinetic relation at phase boundaries, together with the initiation criterion when appropriate, suffice to determine a unique solution of the system of one-dimensional conservation laws governing the dynamics of bars made of a material capable of undergoing phase transformations. The particular type of kinetic relation to be considered here has been motivated both by internal-variable theories of inelastic behavior (ABEYARATNE & KNOWLES (1988a, b), RICE (1970, 1971, 1975)) and by thermodynamical considerations (ABEYARATNE & KNOWLES (1989)). The special elastic material to be studied is one for which stress is a piecewise linear function of strain. The mathematical problem to be treated is the Riemann problem for this "trilinear" material, with the kinetic relation imposed directly at phase boundaries. As in the work of HATTORI (1986a), JAMES (1980) and SLEMROD (1989), we assume here that the dynamical processes occurring in the bar take place isothermally, despite the fact that this is unlikely to be a physically realistic setting. We hope to treat the adiabatic case, as well as the case in which heat conduction is present, in later communications.

In the following section, we present the field equations and jump conditions of the classical one-dimensional theory of elastic bars, and we discuss the energetics of motions in which strain discontinuities occur. In the course of this discussion, we introduce the notion of the "driving traction" — or "Eshelby force" — associated with strain discontinuities, and we state the entropy inequality at such discontinuities in terms of the driving traction. Throughout the present paper, we shall refer to solutions as *admissible* if the entropy inequality is satisfied at each strain discontinuity. The theory as set out in Section 2 applies to elastic bars

with essentially arbitrary stress-strain relations. In Section 3, we consider the special material whose stress-strain relation is trilinear (see Figure 2), and we review the *quasi-static* response of a bar of this material during slow processes in which inertia is unimportant. The notions of a kinetic relation and an initiation criterion for a phase transformation are introduced in this setting. We return to the genuine dynamics of the bar in Section 4, where we describe the local properties of discontinuities; these may correspond either to *shock waves* or to *phase boundaries*. Section 5 is devoted to the formulation of the Riemann problem for the trilinear material. Before attempting to impose the kinetic relation, we show in Section 6 that the admissibility condition alone, although, as expected, not strong enough to deliver uniqueness, is nevertheless responsible for some major qualitative conclusions about the structure of solutions of the Riemann problem. By constructing explicit solutions, we show in Section 7 that, for a large class of initial data, the lack of uniqueness remaining after the imposition of our admissibility requirement is precisely that needed to accommodate the kinetic relation and, where appropriate, the initiation criterion for the relevant phase transition. Section 8 contains further discussion and concluding remarks.

2. Preliminaries

Consider an elastic bar with uniform cross-sectional area A ; the bar is regarded as a one-dimensional continuum that occupies the interval $[0, L]$ in an unstressed reference configuration. In a longitudinal motion of the bar, the particle at x is carried to the point $x + u(x, t)$ at time t , where the displacement u is to be continuous with piecewise continuous first and second derivatives on $[0, L] \times [0, \infty)$. Where u_x and u_t exist, we let

$$\gamma = u_{xx}, \quad v = u_t \tag{2.1}$$

denote strain and particle velocity, respectively. We assume that $\gamma(x, t) > -1$, so that the mapping $x \rightarrow x + u(x, t)$ is invertible at each t . The stress $\sigma(x, t)$ is related to the strain through

$$\sigma = \hat{\sigma}(\gamma), \tag{2.2}$$

where the stress response function $\hat{\sigma}$ is determined by the material. We assume that

$$\hat{\sigma}(0) = 0, \quad \mu \equiv \hat{\sigma}'(0) > 0; \tag{2.3}$$

the first of these conditions reflects the fact that the reference configuration is unstressed, while the second asserts that the tensile modulus at infinitesimal deformations is positive. The mass density ρ of the material in the reference state is taken to be constant.

At points (x, t) in space-time where γ and v are smooth, one has

$$\hat{\sigma}'(\gamma) \gamma_x - \rho v_t = 0, \tag{2.4}$$

$$v_x - \gamma_t = 0, \tag{2.5}$$

provided body forces are absent. If either γ or v is discontinuous across the curve $x = s(t)$ in the x, t -plane, the following jump conditions must be satisfied:

$$[[\sigma]] = -\rho[[v]] \dot{s}, \quad (2.6)$$

$$[[\gamma]] \dot{s} = -[[v]], \quad (2.7)$$

where, for any function $f(x, t)$, $[[f]]$ stands for $f(s(t)^+, t) - f(s(t)^-, t)$. Conditions (2.4) and (2.6) are local consequences of the global balance of linear momentum; (2.5) and (2.7) follow from the smoothness required of $u(x, t)$.

Let

$$W(\gamma) = \int_0^\gamma \hat{\sigma}(\gamma') d\gamma', \quad \gamma > -1, \quad (2.8)$$

be the strain energy per unit reference volume for the material of the bar. Consider the restriction of the motion to the time interval $[t_1, t_2]$ and to the piece of the bar that occupies the interval $[x_1, x_2]$ in the reference state. Suppose that γ and v are smooth on $[x_1, x_2] \times [t_1, t_2]$ *except* at the moving discontinuity $x = s(t)$. Let $E(t)$ be the total mechanical energy at time t for the piece of the bar under consideration:

$$E(t) = \int_{x_1}^{x_2} [W(\gamma(x, t)) + \frac{1}{2} \rho v^2(x, t)] A dx. \quad (2.9)$$

A direct calculation that makes use of (2.4)–(2.9) establishes the following work-energy identity:

$$\sigma(x_2, t) A v(x_2, t) - \sigma(x_1, t) A v(x_1, t) - \dot{E}(t) = f(t) A \dot{s}(t), \quad (2.10)$$

where $f(t)$ is defined by

$$f = \hat{f}(\bar{\gamma}, \bar{\gamma}^+) \equiv \int_{\bar{\gamma}}^{\bar{\gamma}^+} \hat{\sigma}(\gamma) d\gamma - \frac{1}{2} [\hat{\sigma}(\bar{\gamma}^+) + \hat{\sigma}(\bar{\gamma})] (\bar{\gamma}^+ - \bar{\gamma}), \quad (2.11)$$

and $\bar{\gamma}^\pm(t) = \gamma(s(t) \pm, t)$ are the strains on the two sides of the discontinuity. The left side of (2.10) represents the excess of the rate of work of the external forces acting on the piece of the bar over the rate of storage of mechanical energy. If there is *no* jump in strain at $x = s(t)$, then (2.11) would give $f = 0$, and the rate of work of the external forces would be exactly balanced by the rate of increase of energy. When there *is* a strain jump, the right side of (2.10) need not vanish, and each side of (2.10) would then represent the rate of dissipation of mechanical energy associated with the moving discontinuity. We may think of $-f(t) A \dot{s}(t)$ as the rate of work done *on* the bar *by* the moving discontinuity; correspondingly, we speak of f as the *driving traction* acting on the discontinuity.

If the material of the bar is *linear*, so that $\hat{\sigma}(\gamma) = \mu\gamma$, then (2.11) yields $\hat{f}(\bar{\gamma}, \bar{\gamma}^+) = 0$. Thus for a linear material, the driving traction vanishes at any discontinuity, so motions of the bar are automatically dissipation-free. More generally, if $\hat{\sigma}(\gamma)$ is linear only over an *interval* of strain, say $[\gamma_1, \gamma_2]$, it follows from (2.11)

that $f(t)$ vanishes at any discontinuity for which the limiting strains $\overset{+}{\gamma}(t)$ and $\bar{\gamma}(t)$ both lie in $[\gamma_1, \gamma_2]$.

A geometric interpretation of $\hat{f}(\bar{\gamma}, \overset{+}{\gamma})$ is exemplified in Figure 1: $\hat{f}(\bar{\gamma}, \overset{+}{\gamma}) = A - B$, where A and B are the areas of the two regions A and B generated by the stress-strain curve and the trapezoid determined by $\bar{\gamma}$, $\overset{+}{\gamma}$, $\hat{\sigma}(\bar{\gamma})$, and $\hat{\sigma}(\overset{+}{\gamma})$.

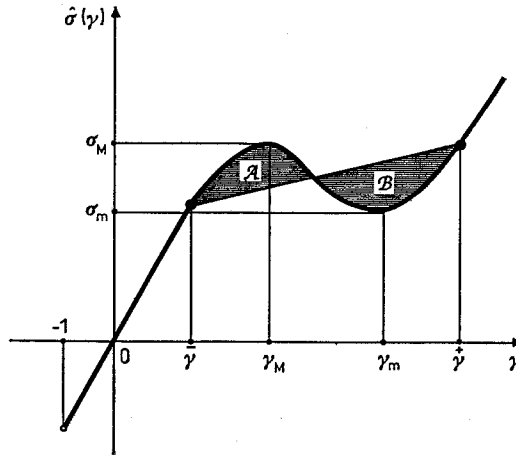

Fig. 1. Stress-strain curve

The driving traction on a strain discontinuity is related to the notion of the “force on a defect” introduced in an equilibrium context by ESHELBY (1956). It is also the counterpart — considered here only in one space dimension — of the force on an interface between two elastic phases derived by ESHELBY (1970) and discussed by RICE (1975); see also KNOWLES (1979). The notion of driving traction can be given meaning in a much more general setting than that envisaged here. Indeed, it has been introduced in connection with surfaces of discontinuity in three-dimensional thermo-mechanical processes taking place in an arbitrary continuum by ABEYARATNE & KNOWLES (1989); see also TRUSKINOVSKY (1987).

The basic field equations and jump conditions (2.4)–(2.7) do not guarantee that the instantaneous dissipation rate in (2.10) is non-negative. The condition that this be so is clearly

$$f(t) \dot{s}(t) \geq 0. \tag{2.12}$$

We shall speak of the motion of the bar as *admissible* if (2.12) holds at each discontinuity and for all time. If the material under consideration here is regarded as thermoelastic, and if the dynamical processes being studied are assumed to take place at constant temperature, the condition (2.12), with f given by (2.11), can be shown to be a consequence of the Clausius-Duhem version of the second law of thermodynamics. The assumption of isothermality, however, is more appropriate for *slow* processes, in which inertia forces and kinetic energy are unimportant, than for the processes considered here. Nonetheless, for simplicity,

we shall retain (2.12), (2.11), deferring to future work a consideration of the adiabatic case or the even more realistic case in which heat conduction is included. For related discussion, see ABEYARATNE & KNOWLES (1989).

3. The trilinear material: Equilibrium states and quasi-static motions

Before pursuing the dynamical issues of principal interest to us here, it is essential to review briefly the corresponding theory of equilibrium states and related quasi-static motions. Accordingly, we seek equilibrium solutions of the field equations (2.4), (2.5) and the jump conditions (2.6), (2.7). When the displacement $u(x, t)$ is independent of time t , the strain γ , the stress σ and the discontinuity location s have this property as well, and the particle velocity v vanishes. Conditions (2.5) and (2.7) are now trivially satisfied, and (2.4), (2.6) imply that $\sigma(x) = \sigma = \text{constant}$ for $0 \leq x \leq L$. If the stress response function $\hat{\sigma}(\gamma)$ were strictly increasing with γ , (2.2) would show that γ also is constant along the bar, so that no strain discontinuities could occur in the equilibrium field, and the bar would find itself in a homogeneously deformed state of extension or contraction.

For a stress-strain curve of the form shown in Figure 1, however, the situation is different. For stress levels between the local minimum σ_m and the local maximum σ_M , equilibrium fields in the bar are possible in which the stress σ is constant along the bar, but the strain γ is only *piecewise* constant, in general taking any one of three possible values corresponding to the given σ . We regard such states as mixtures of phases; we say a particle of the bar located at x in the reference state is in phase 1, 2 or 3 at time t during a motion if $\gamma(x, t)$ lies in the interval $(-1, \gamma_M]$, (γ_M, γ_m) or $[\gamma_m, \infty)$, respectively. Since our interest here is in phase mixtures, we shall be concerned with a stress-strain curve of the form shown in Figure 1. Insofar as our review of equilibrium fields and quasi-static motions is concerned, the discussion could be carried out without specifying the stress-strain relation in detail beyond the qualitative requirement that it be at first rising, then

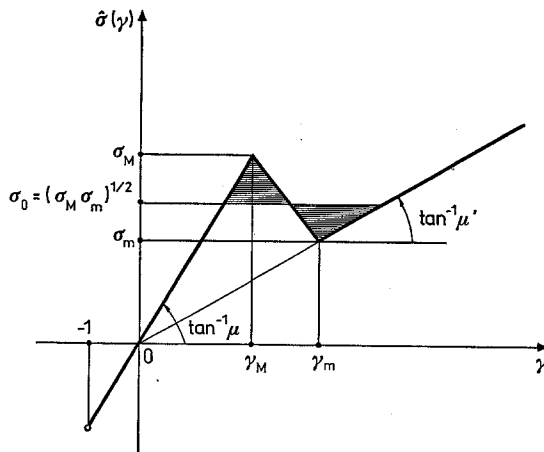

Fig. 2. Stress-strain curve for the trilinear material

declining and finally rising again, as in Figure 1; see ABAYARATNE & KNOWLES (1988a). For the *dynamics* of phase mixtures, however, the simplifications provided by the *trilinear* stress-strain relation illustrated in Figure 2 turn out to be enormously helpful. We thus confine our attention from here on to the case of the trilinear material; we shall comment on the seriousness of this restriction in the final section.

Let the stress σ in the bar be given, with $\sigma_m \leq \sigma \leq \sigma_M$. We consider displacement fields for which the corresponding strain is piecewise constant with a single discontinuity at $x = s$, where s is given arbitrarily in $[0, L]$. Such a field is said to be of p, q -type if the strain is in phase p to the left of $x = s$, and in phase q to the right, $p, q = 1, 2, 3$. If $p = q$, the strain is continuous at $x = s$; if $p \neq q$, we refer to $x = s$ as a phase boundary. For example,

$$u(x) = \begin{cases} \sigma x / \mu, & 0 \leq x \leq s, \\ \sigma x / \mu' + (1/\mu - 1/\mu') \sigma s, & s \leq x \leq L, \end{cases} \quad (3.1)$$

represents a continuous equilibrium displacement field of 1,3-type that gives rise to the given stress σ . Here μ and $\mu' (< \mu)$ are the tensile moduli for phase 1 and phase 3, respectively; see Figure 2. For an equilibrium field of p, q -type and for a given s , the relation $\delta = \Delta_{pq}(F, s)$ between the overall elongation of the bar $\delta = u(L) - u(0)$ and the applied force $F = \sigma A$ is called the *macroscopic response* of the bar. For the field of 1,3-type corresponding to (3.1), one has

$$\delta = \Delta_{13}(F, s) \equiv \left[\left(\frac{1}{\mu} - \frac{1}{\mu'} \right) s + \frac{L}{\mu'} \right] \frac{F}{A}, \quad \sigma_m A \leq F \leq \sigma_M A, \quad 0 \leq s \leq L. \quad (3.2)$$

When $s = L$, the displacement field in (3.1) is smooth, and all particles of the bar are in phase 1; this suggests that we set $\Delta_{11}(F) = \Delta_{13}(F, L)$ for $\sigma_m A \leq F \leq \sigma_M A$. Similarly, if $s = 0$, $u(x)$ is smooth and the entire bar is in phase 3; we set $\Delta_{33}(F) = \Delta_{13}(F, 0)$, $\sigma_m A \leq F \leq \sigma_M A$.

If the given stress σ is less than σ_m or greater than σ_M , the corresponding displacement field is smooth and unique. We speak of these as fields of 1,1-type in the former case, 3,3-type in the latter. The corresponding macroscopic responses are

$$\delta = \Delta_{11}(F) = FL/\mu A, \quad -\mu A < F < \sigma_m A; \quad \delta = \Delta_{33}(F) = FL/\mu' A, \quad F > \sigma_M A. \quad (3.3)$$

The macroscopic response for a field of 1,3-type is illustrated in Figure 3. The dashed lines represent graphs of $\delta = \Delta_{13}(F, s)$ vs. F for various constant values of s . Points on OPQ correspond to smooth phase-1 fields, with macroscopic response $\delta = \Delta_{11}(F)$; points on SRT refer to smooth phase-3 fields, $\delta = \Delta_{33}(F)$. Points in the interior of the quadrilateral $PQRS$ or on the horizontal portions of its boundary correspond to mixtures of phase 1 and phase 3. Observe that, for a given stress σ in $[\sigma_m, \sigma_M]$, there are *infinitely many* equilibrium states of 1,3-type. To render the corresponding 1,3-response unique, one must also specify the value of the "internal variable" s .

For a 1,3-equilibrium mixture of phases in a trilinear material, the driving traction defined in (2.11) specializes to

$$f = \frac{1}{2} \frac{\mu - \mu'}{\mu\mu'} (\sigma_0^2 - \sigma^2), \quad \sigma_m \leq \sigma \leq \sigma_M, \quad (3.4)$$

where $\sigma_0 = (\sigma_M \sigma_m)^{1/2}$. Note that the driving traction vanishes when the stress σ in the bar coincides with σ_0 ; σ_0 is called the *Maxwell stress*, and it is such that the hatched areas in Figure 2 are equal. As the stress σ increases from σ_m to σ_M the static driving traction given by (3.4) decreases from a maximum value of $f_M = f_0(1 - \sigma_m/\sigma_M) > 0$ to a minimum value of $f_m = f_0(1 - \sigma_M/\sigma_m) < 0$, where the constant f_0 is given by $f_0 = (1/2) (\mu - \mu') \gamma_m \gamma_M > 0$. If $E(F, s)$ is the total strain energy in the bar for a given force F and a given location s of the phase boundary, and if $U(F, s) = E(F, s) - F \Delta_{1,3}(F, s)$ is the corresponding potential energy, it can be shown that $\partial U(F, s)/\partial F = -\delta$ and $\partial U(F, s)/\partial s = -Af$. In particular, the driving traction f and the internal variable s are *conjugate*. In the more general setting of ABEYARATNE & KNOWLES (1989), f and s are shown to be conjugates with respect to the entropy production rate.

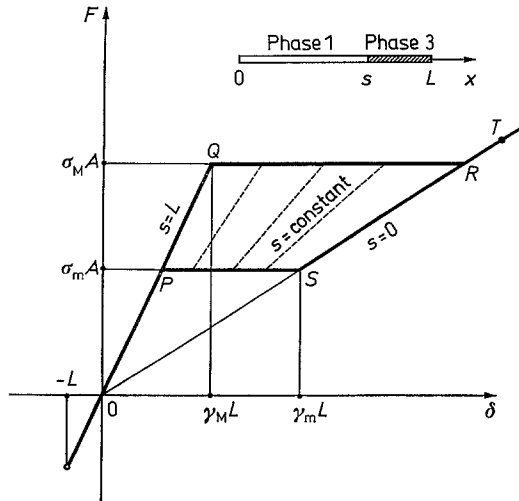

Fig. 3. Macroscopic response for equilibrium fields of 1,3-type

A 1,3-*quasi-static motion* is obtained by replacing the stress σ and the phase boundary location s in (3.1) by functions of time: $\sigma = \sigma(t)$, $s = s(t)$. The driving traction then becomes a function of time as well, and the admissibility condition (2.12), together with (3.4), yields

$$[\sigma(t) - \sigma_0] \dot{s}(t) \leq 0, \quad (3.5)$$

as long as $\sigma_m \leq \sigma \leq \sigma_M$. A 1,3-*quasi-static motion* determines a path in the quadrilateral $PQRS$ of Figure 3; the inequality (3.5) restricts the direction of this path. When $\sigma(t)$ exceeds the Maxwell stress σ_0 , condition (3.5) requires that $\dot{s}(t) \leq 0$, so that the phase boundary $x = s(t)$ cannot move to the right, and the

direction of the path generated in $PQRS$ must be in accord with the arrows in Figure 4. Thus when $\sigma(t)$ is larger than σ_0 , the length of the phase-3 portion of the bar cannot decrease, and particles at the phase boundary are transforming from phase 1 to phase 3. The opposite conclusions apply when $\sigma(t) < \sigma_0$. When the stress coincides with the Maxwell stress, one has $f = 0$ and the admissibility condition (3.5) holds trivially; thus travel in either direction along the "Maxwell line" $F = \sigma_0 A$ is possible, as indicated in Figure 4.

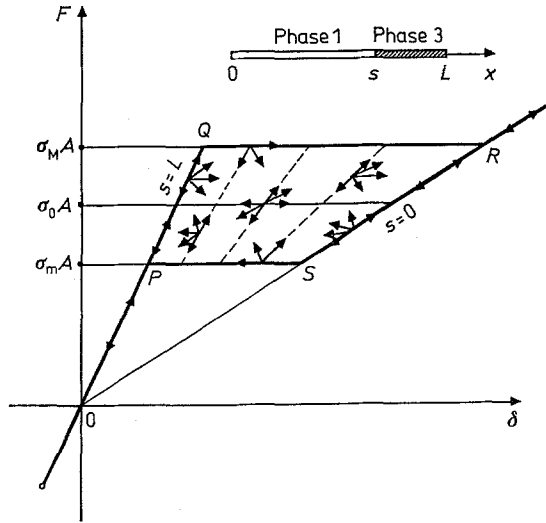

Fig. 4. Admissible directions for paths of 1,3-quasi-static motions

Specifying the stress history $\sigma(\tau)$, $0 \leq \tau \leq t$, in a 1,3-quasi-static motion is *not* sufficient to determine the present value of the elongation, *even with admissibility* (2.12) *enforced*, since $s(t)$ must be known as well. As viewed by ABEYARATNE & KNOWLES (1988a), this reflects a constitutive deficiency which can be remedied by annexing to the field equations, the jump conditions and the admissibility requirement, a *kinetic relation* that controls the rate at which particles of the bar transform from one phase to the other, as well as an *initiation* (or *nucleation criterion*) for a phase transition. Specific types of kinetic relations and nucleation criteria, often based on thermal activation arguments, have long been discussed in the metallurgical literature concerned with phase transformations in solids, especially for those transformations in which diffusion is an important mechanism. The reader may refer, for example, to FINE (1964), PORTER & EASTERLING (1981) and RALLS, COURTNEY & WULFF (1976).

We shall postulate a simple form of kinetic relation in which the driving traction $f(t)$ is a function of the time rate of change $\dot{s}(t)$ of its conjugate internal variable $s(t)$; $\dot{s}(t)$ clearly measures the rate at which one phase is transforming to the other. Thus we assume that there is a constitutive function φ_{13} such that, during a 1,3-quasi-static motion,

$$f(t) = \varphi_{13}[\dot{s}(t)]. \tag{3.6}$$

Because of the admissibility condition (2.12), the kinetic response function φ_{13} is subject to the restriction

$$\varphi_{13}(\dot{s}) \dot{s} \geq 0 \tag{3.7}$$

for all \dot{s} . We shall assume that the graph of the function φ_{13} has the form indicated schematically by the curve K^* in Figure 5. The kinetic response function φ_{13} is to be monotonically increasing and smooth everywhere except possibly at $\dot{s} = 0$. We let $\varphi_{13}(0+) = f_M^* \geq 0$, $\varphi_{13}(0-) = f_m^* \leq 0$, $\varphi_{13}(+\infty) = f_M$, $\varphi_{13}(-\infty) = f_m$, where f_M^* and f_m^* are new material parameters, and f_M and f_m , introduced earlier, are the maximum and minimum values of driving traction. For values of the driving traction between f_m^* and f_M^* , no motion of the phase boundary is possible, reflecting a frictional type of relationship between driving traction and phase boundary velocity. It may happen that $f_m^* = f_M^* = 0$, in which case $\varphi_{13}(\dot{s})$ is continuous at $\dot{s} = 0$, and motion of the phase boundary takes place whenever the driving traction is different from zero. The hatched region in Figure 5 comprises the set of all points (\dot{s}, f) with $f_m \leq f \leq f_M$ for which the admissibility condition $f\dot{s} \geq 0$ holds.

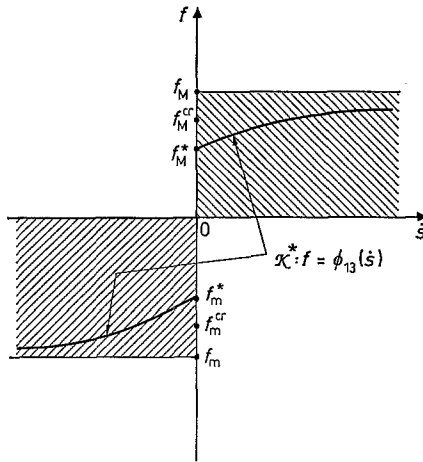

Fig. 5. Kinetic relation $f = \varphi_{13}(\dot{s})$

Once a 1,3-phase boundary has been initiated, the kinetic relation (3.6) controls its evolution. A separate criterion is needed to signal the emergence of such a phase boundary from a *single*-phase configuration. In general, a particle may change its phase in one of two ways: a pre-existing phase boundary may pass through it, or it may undergo a *spontaneous* phase transition. In the latter case, the transition generates *two new phase boundaries* if the particle lies in the interior of a single-phase interval, *one new phase boundary* if the particle is at an end of the bar. Since the bar is uniform in cross-section and materially homogeneous, there is no distinction between different particles of the bar in a single-phase equilibrium state. Presumably, a spontaneous phase transition could therefore begin with equal likelihood at *any* point in the bar. Thus we shall suppose arbitrarily that, whenever the bar is in a uniform phase 1 state, a spontaneous

phase 1 \rightarrow phase 3 transition accompanied by an emergent phase boundary can occur *only* at $x = L$. We further assume that the occurrence of such a spontaneous 1 \rightarrow 3 transition is controlled by a critical value f_m^{cr} of driving traction: when the stress σ at the particle labeled by $x = L$ has increased to a value such that, according to (3.4), the corresponding driving traction f is not greater than f_m^{cr} , this particle spontaneously transforms to phase 3, thus initiating a 1,3-phase boundary at $x = L$. This phase boundary then moves leftward into the bar in accordance with the kinetic relation (3.6). By (3.4), the stress σ^{cr} corresponding to $f = f_m^{cr}$ is

$$\sigma^{cr} = \sigma_0 \left(1 - \frac{f_m^{cr}}{f_0} \right)^{1/2}; \tag{3.8}$$

thus the phase 1 \rightarrow phase 3 transformation is initiated when $\sigma \geq \sigma^{cr}$. Since by admissibility $f_m^{cr} \leq 0$, it follows that σ^{cr} is at least as great as the Maxwell stress. Similarly, if the bar is in a pure phase 3 state, spontaneous transformation from phase 3 to phase 1 of the particle labeled by $x = 0$ is assumed to occur when the stress σ has diminished to a value such that the associated driving traction in (3.4) is at least as great as a critical value f_M^{cr} ; the corresponding critical stress in this case is *less* than σ_0 . Under these circumstances, a 1,3-phase boundary is initiated at $x = 0$, and it moves with positive velocity \dot{s} into the bar in accordance with (3.6). The initiation levels of driving traction f_m^{cr} and f_M^{cr} are material parameters that satisfy the following inequalities: $f_m < f_m^{cr} \leq f_m^* \leq 0 \leq f_M^* \leq f_M^{cr} < f_M$.

As shown in detail in ABEYARATNE & KNOWLES (1988a), a kinetic relation (3.6) in which φ_{13} has the form shown in Figure 5, together with the initiation criterion, gives rise to a fully determinate response. When the bar is first quasi-statically loaded *from* the reference state and then unloaded *to* the reference state, the associated force-elongation curve is as shown in Figure 6; generally, the response is hysteric and rate-dependent.

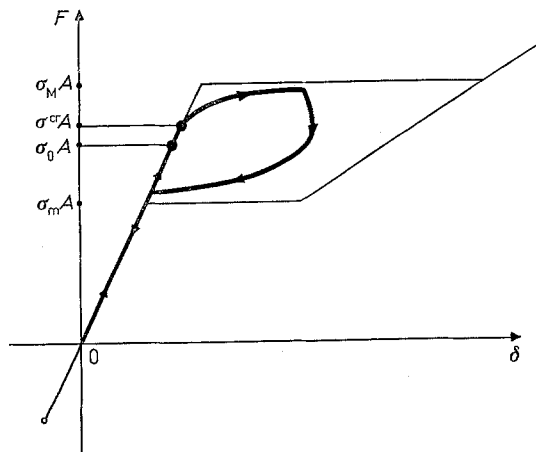

Fig. 6. Force-elongation curve for loading followed by unloading

A treatment analogous to that summarized above for 1,3-quasi-static motions can be provided for motions involving equilibrium fields of p, q type for any p and q , as well as for transitions from one type of motion to another. For a more extensive discussion, see ABEYARATNE & KNOWLES (1988a).

4. Dynamics: local properties of discontinuities

Returning to the dynamical processes described in Section 2, we note from (2.6), (2.7) that the velocity \dot{s} of a moving discontinuity at $x = s(t)$ satisfies

$$\rho \dot{s}^2 = \frac{\hat{\sigma}(\bar{\gamma}^+) - \hat{\sigma}(\bar{\gamma}^-)}{\bar{\gamma}^+ - \bar{\gamma}^-}, \tag{4.1}$$

where $\bar{\gamma}^\pm$ are the limiting strains on either side of the discontinuity. From this it follows that the slope of the chord joining the points $(\bar{\gamma}^-, \hat{\sigma}(\bar{\gamma}^-))$ and $(\bar{\gamma}^+, \hat{\sigma}(\bar{\gamma}^+))$ on the stress-strain curve must necessarily be non-negative. Conversely, one can show readily that if a pair $\bar{\gamma}^-, \bar{\gamma}^+$ satisfies this condition, there exist numbers \bar{v}^-, \bar{v}^+ and \dot{s} that, together with $\bar{\gamma}^-, \bar{\gamma}^+$, satisfy the jump conditions (2.6), (2.7). The pairs of distinct strains $\bar{\gamma}^-, \bar{\gamma}^+$ that can occur at a discontinuity are thus those that make the right side of (4.1) non-negative. For the trilinear material, the set I of all such pairs corresponds to those points in $(-1, \infty) \times (-1, \infty)$ that lie on or outside the irregular hexagon $ABCDEF$ and off the line $\bar{\gamma}^+ = \bar{\gamma}^-$ in the $\bar{\gamma}^-, \bar{\gamma}^+$ -plane shown in Figure 7. The figure explicitly indicates the subregions Γ_{pq} of I that correspond to discontinuities of p, q -type for various p, q .

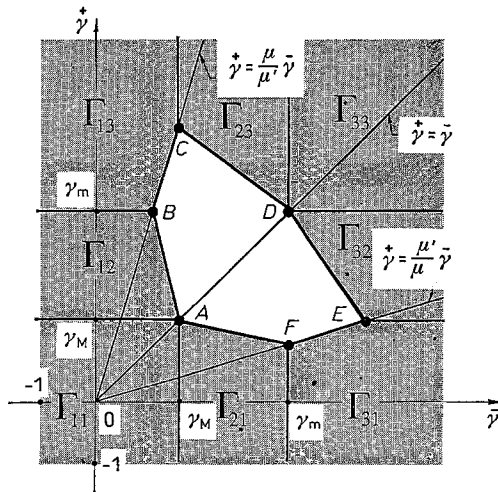

Fig. 7. The set I (shown shaded) of possible pairs of strains $\bar{\gamma}^-, \bar{\gamma}^+$ at a strain discontinuity

If $\bar{\gamma}$ is in phase p and $\overset{+}{\gamma}$ in phase q , we call the associated p, q -discontinuity a *shock wave* if $p = q$, a *phase boundary* if $p \neq q$. (Because shock waves here relate to a *linear* part of the stress-strain curve, “acoustic waves” might be a more appropriate term; this would *not* be the case, however, for more general materials of the kind represented by Figure 1.) Condition (4.1) clearly rules out shock waves of 2,2-type. For the trilinear material, (4.1) yields

$$c = (\mu/\rho)^{1/2}, \quad c' = (\mu'/\rho)^{1/2} < c, \tag{4.2}$$

as the (constant) speeds of shock waves of 1,1- and 3,3-type, respectively. For phase boundaries, one shows easily that the ranges of the velocity \dot{s} permitted by (4.1) are as given in Table 1 for the various combinations of phases.

Table 1

Type of phase boundary	Range of velocity
1,3 or 3,1	$0 \leq \dot{s}^2 < c_*^2$
2,3 or 3,2	$0 \leq \dot{s}^2 < c'^2$
2,1 or 1,2	$0 \leq \dot{s}^2 < c^2$

In Table 1,

$$c_* = \left(\frac{c^2 + \gamma_m c'^2}{1 + \gamma_m} \right)^{1/2}. \tag{4.3}$$

With the help of Figure 2, one shows easily that ρc_*^2 is the maximum slope of the chord connecting two points on the trilinear stress-strain curve, one of which lies in phase 1, the other in phase 3. Note that $c' < c_* < c$. A phase boundary for which $|\dot{s}| < c'$ is said to be subsonic; it is supersonic if $|\dot{s}| > c'$. It should be observed from the table that the cases for which $\dot{s} = 0$, corresponding to stationary phase boundaries, are not excluded. They correspond to points on the hexagon $ABCDEF A$ in Figure 7; at all such points, $\hat{\sigma}(\overset{+}{\gamma}) = \hat{\sigma}(\bar{\gamma})$, as in the case of the equilibrium phase boundaries discussed in the previous section.

At any strain discontinuity, there is a driving traction. For a *shock wave* in a trilinear material, $f = 0$, because, as remarked in Section 2, the driving traction at a discontinuity vanishes whenever the strains on the two sides are such that the stress-strain curve is linear between them. On the other hand, for a *phase boundary* of 1,3-type, the definition (2.11) yields

$$f = \hat{f}_{13}(\bar{\gamma}, \overset{+}{\gamma}) \equiv \frac{1}{2} (\mu - \mu') (\gamma_M \gamma_m - \overset{+}{\gamma} \bar{\gamma}), \tag{4.4}$$

while for a 3,1-discontinuity,

$$f = \hat{f}_{31}(\bar{\gamma}, \overset{+}{\gamma}) \equiv \frac{1}{2} (\mu - \mu') (\overset{+}{\gamma} \bar{\gamma} - \gamma_M \gamma_m) = -\hat{f}_{13}(\bar{\gamma}, \overset{+}{\gamma}). \tag{4.5}$$

When $\overset{+}{\sigma} = \bar{\sigma}$, (4.4) can be immediately reduced to the representation (3.4) for the static driving traction.

For discontinuities involving phase 2, it is easily seen that

$$\hat{f}_{12}(\bar{\gamma}, \bar{\gamma}^+) > 0, \quad \hat{f}_{21}(\bar{\gamma}, \bar{\gamma}^+) < 0, \quad \hat{f}_{32}(\bar{\gamma}, \bar{\gamma}^+) > 0, \quad \hat{f}_{23}(\bar{\gamma}, \bar{\gamma}^+) < 0, \quad (4.6)$$

for all appropriate values of $\bar{\gamma}$ and $\bar{\gamma}^+$. Since discontinuities involving phase 2 turn out to be unimportant, we do not need explicit formulas for the driving tractions occurring in (4.6).

The admissibility inequality (2.12) is trivially satisfied for shock waves, which are dissipation-free for the trilinear material. For phase boundaries, however, the admissibility requirement has strong implications. To begin with, it further restricts the ranges of the phase boundary velocities, nominally given by the inequalities in Table 1. For a 1,3-phase boundary, for example, (4.4) shows that the driving traction $f = \hat{f}_{13}(\bar{\gamma}, \bar{\gamma}^+)$ vanishes on the portion of the hyperbola $\bar{\gamma}^+ \bar{\gamma} = \gamma_M \gamma_m$ that lies in the 1,3-region Γ_{13} of Figure 7; the driving traction at a 1,3-phase boundary is thus positive for strain pairs $\bar{\gamma}, \bar{\gamma}^+$ that correspond to points on one side of this hyperbola, negative at points on the other side. By (2.12), the sign of the phase boundary velocity \dot{s} is restricted accordingly, as illustrated in Figure 8. It is easily shown that, in the part of Γ_{13} where $\dot{s} > 0$, the supremum of the values of \dot{s}^2 is c_*^2 , but where $\dot{s} < 0$, the supremum is c'^2 . Combining this restriction with the appropriate entry in Table 1 yields the more restricted range $-c' < \dot{s} < c^*$ for the phase boundary velocity. Similar considerations apply to the other cases; the results are summarized in Table 2. If the material *into*

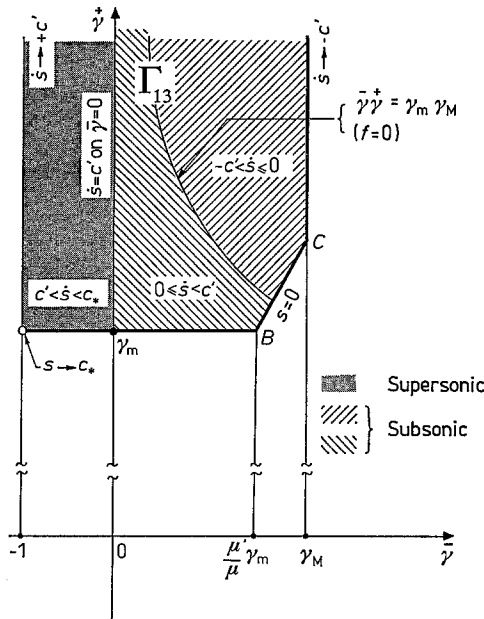

Fig. 8. Variation of phase boundary velocity \dot{s} in Γ_{13}

which a phase boundary is advancing is said to be in the *parent* phase, the first two lines of Table 2 assert that if a phase boundary between phases 1 and 3 is supersonic, then the parent phase is necessarily in phase 3.

Table 2

Type of phase boundary	Range of admissible velocity
1,3	$-c' < \dot{s} < c_*$
3,1	$-c_* < \dot{s} < c'$
2,3	$-c' < \dot{s} \leq 0$
3,2	$0 \leq \dot{s} < c'$
2,1	$-c < \dot{s} \leq 0$
1,2	$0 \leq \dot{s} < c$

Figure 8 also shows the subregions of Γ_{13} that correspond to subsonic and supersonic phase boundary velocities. Further implications of admissibility arise in Section 6.

Next, it is convenient to record here some formulas that will be useful later. Suppose that $x = s(t)$ is a 1,3-phase boundary at time t ; from (4.1), (4.2) and the explicit form of the trilinear stress response function $\hat{\sigma}(\gamma)$, one can relate $\bar{\gamma}(t)$ to $\dot{\gamma}^+(t)$ and $\dot{s}(t)$ by

$$\dot{\gamma}^+ = \beta(\dot{s}) \bar{\gamma} \quad (1,3\text{-case}), \quad (4.7)$$

where $\beta(\dot{s})$ is defined in terms of the wave speeds c and c' by

$$\beta(\dot{s}) = \frac{c^2 - \dot{s}^2}{c'^2 - \dot{s}^2}, \quad \dot{s} \neq \pm c'. \quad (4.8)$$

Similarly, at a 3,1-phase boundary, one has

$$\dot{\gamma}^+ = \frac{1}{\beta(\dot{s})} \bar{\gamma} \quad (3,1\text{-case}). \quad (4.9)$$

Finally, we use (4.1) and (2.11) to map the set I' of possible strains at a discontinuity from the $\bar{\gamma}, \dot{\gamma}^+$ -plane of Figure 7 to the \dot{s}, f -plane of Figure 5. For our purposes, it is sufficient to describe the restriction of this mapping to the subregion Γ_{13} of I' that corresponds to phase boundaries of 1,3-type; see Figure 8. To do this, we make use of the explicit formulas (4.4), (4.7). Each point $(\bar{\gamma}, \dot{\gamma}^+)$ in Γ_{13} that does *not* lie on the segment BC in Figure 8 is carried to *two* points $(+\dot{s}, f)$ and $(-\dot{s}, f)$ in the \dot{s}, f -plane, only one of which satisfies the admissibility condition (2.12). In contrast, each point *on* BC maps to a single point $(0, f)$, trivially admissible, on the f -axis, with $f_m \leq f \leq f_M$, where f_m and f_M are the minimum and maximum values of the *static* driving traction. *All* points on the $\dot{\gamma}^+$ -axis in Γ_{13} correspond to phase boundaries travelling at the sonic speed c' ; they map to the *same* pair of points $(\pm c', f_0)$ in the (\dot{s}, f) -plane. Each point $(\bar{\gamma}, \dot{\gamma}^+)$ on the hyperbola

$\bar{\gamma}^+ \gamma^- = \gamma_m \gamma_M$ in Γ_{13} maps to a pair of points $(\pm \dot{s}, 0)$ on the \dot{s} -axis, with $0 \leq \dot{s} < c'$. Figure 9 shows the *admissible* image in the (\dot{s}, f) -plane of the region Γ_{13} in the $(\bar{\gamma}, \gamma^+)$ -plane, which is shown in the inset; hatched regions in the two planes correspond, as do dotted regions.

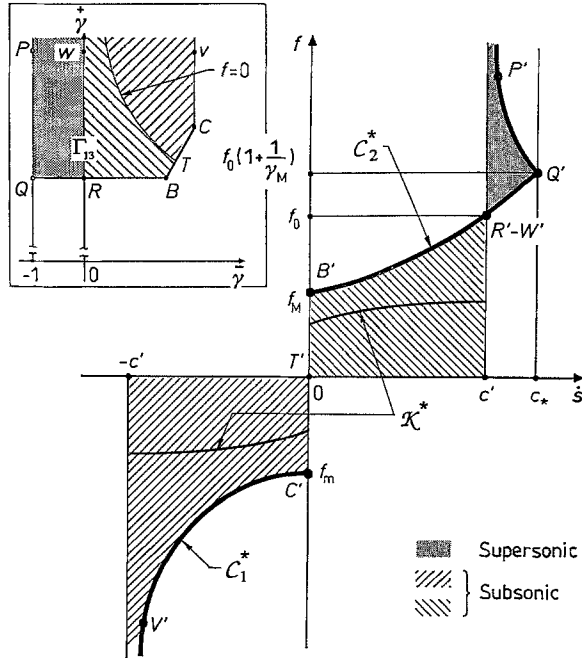

Fig. 9. Admissible image of Γ_{13} (inset) in \dot{s}, f -plane

A significant conclusion can be drawn from Figures 5 and 9: *the quasi-statically admissible region of Figure 5 (shown hatched), when truncated so as to allow only subsonic phase boundary speeds $|\dot{s}| < c'$, is a subset of the dynamically admissible region of Figure 9.* The curve K^* in Figure 9 is now the graph of the restriction to subsonic speeds of the kinetic response function $f = \varphi_{13}(\dot{s})$.

5. The Riemann problem

We now formulate the Riemann problem for the field equations and jump conditions (2.4)–(2.7). We seek weak solutions of the differential equations (2.4), (2.5) on the upper half of the x, t -plane that satisfy the following initial conditions:

$$\gamma(x, 0+) = \begin{cases} \gamma_L, & -\infty < x < 0, \\ \gamma_R, & 0 < x < +\infty, \end{cases} \quad v(x, 0+) = \begin{cases} v_L, & -\infty < x < 0, \\ v_R, & 0 < x < +\infty, \end{cases} \quad (5.1)$$

where $\gamma_L, \gamma_R, v_L,$ and v_R are given constants, with $\gamma_L > -1, \gamma_R > -1$.

In order to motivate the class of functions in which the solution is to be sought, we first note that the initial value problem is formally invariant under the scale change $x \rightarrow kx$, $t \rightarrow kt$, suggesting that we seek solutions with this invariance property as well. Where such solutions are smooth, they must have the form $\gamma = \gamma(x/t)$, $v = v(x/t)$; it then follows from (2.4) and (2.5) that, in a domain where γ and v are smooth, either γ and v are both constant, or the equality $\hat{\sigma}'(\gamma(x/t)) = \varrho(x/t)^2$ must hold. But for the trilinear material, $\hat{\sigma}'(\gamma)$ is piecewise constant, so that fans cannot occur, and the last relation can hold only on shock waves. If either γ or v jumps at $x = s(t)$, then the fact that γ and v are constant on either side of $x = s(t)$ necessarily requires that $s(t) = \dot{s}t$, where \dot{s} is a constant. We conclude that solutions with the invariance property described above must have the following form:

$$\gamma(x, t) = \gamma_j, \quad v(x, t) = v_j, \quad \dot{s}_j t \leq x \leq \dot{s}_{j+1} t, \quad j = 0, 1, \dots, N, \quad (5.2)$$

where γ_j , v_j , \dot{s}_j and N are constants, with N a non-negative integer, and $\gamma_0 = \gamma_L$, $\gamma_N = \gamma_R$, $v_0 = v_L$, $v_N = v_R$, $\dot{s}_0 = -\infty$, $\dot{s}_{N+1} = +\infty$; see Figure 10. The case $N = 0$ can occur only if $\gamma_L = \gamma_R$ and $v_L = v_R$. The γ_j 's are required to satisfy $\gamma_j > -1$ for $j = 0, \dots, N$; if $N > 0$, it is also required that $\gamma_j \neq \gamma_{j+1}$, $j = 0, \dots, N - 1$. In the field given by (5.2), there are N strain discontinuities on lines $x = \dot{s}_j t$; they may be shock waves or phase boundaries. If $x = \dot{s}_j t$ is a shock wave, then \dot{s}_j must take one of the four values $\pm c$, $\pm c'$. Since by Table 2, no discontinuity can travel faster than c , we have

$$-c \leq \dot{s}_1 < \dot{s}_2 < \dots < \dot{s}_N \leq c. \quad (5.3)$$

We seek solutions of the Riemann problem in the class of all functions of the form described above.

At each discontinuity, the jump conditions (2.6), (2.7) must be satisfied, so that

$$\left. \begin{aligned} s_j(\gamma_j - \gamma_{j-1}) &= -(v_j - v_{j-1}), \\ \hat{\sigma}(\gamma_j) - \hat{\sigma}(\gamma_{j-1}) &= -\varrho \dot{s}_j (v_j - v_{j-1}), \end{aligned} \right\} \quad j = 1, \dots, N, \quad (5.4)$$

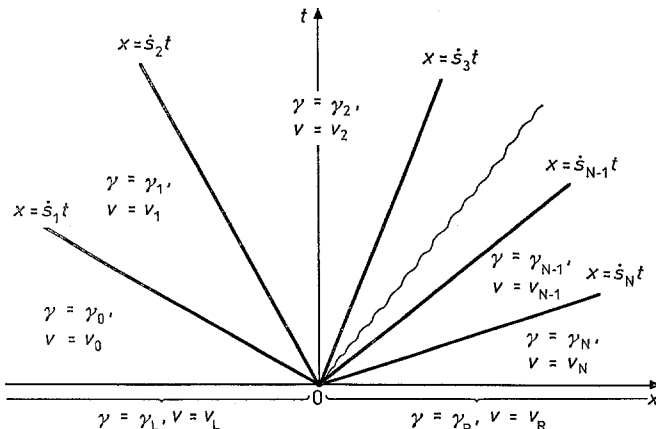

Fig. 10. Assumed form of solutions to the Riemann problem

where it is understood that $\hat{\sigma}$ is the stress response function for the trilinear material (Figure 2). Let f_j stand for the driving traction on the discontinuity at $x = \dot{s}_j t$; the admissibility condition (2.12) then requires that

$$f_j \dot{s}_j \geq 0, \quad j = 1, \dots, N. \quad (5.5)$$

An admissible solution of the Riemann problem is a pair $\gamma(x, t), v(x, t)$ of the form (5.2) such that (5.3)–(5.5) hold. We shall find that, in general, this Riemann problem has many admissible solutions.

6. General features of the Riemann problem

We shall call the initial data in (5.1) *metastable* if neither of the initial strains γ_L, γ_R belongs to phase 2. From here on, we shall consider only this case. Before constructing explicit global solutions, it is convenient to establish some general results pertaining to the structure of admissible solutions when the initial data are metastable.

Let (γ, v) be an admissible solution to a Riemann problem with metastable initial data. Then

- (i) for $j = 0, \dots, N$, no strain γ_j in (5.2) belongs to phase 2;
- (ii) (γ, v) involves at most two subsonic phase boundaries; if there are two, one moves with non-negative speed the other with non-positive speed;
- (iii) (γ, v) involves at most two supersonic phase boundaries; if there are two, one moves with positive speed the other with negative speed;
- (iv) either all phase boundaries are subsonic, or all are supersonic.

To prove (i), we first note that the result is trivially true if $N = 0$ or 1, so we may assume that $N \geq 2$. Suppose that, for some $k \neq 0, N$, we have γ_k in phase 2. Since 2,2-shock waves do not exist, neither γ_{k-1} nor γ_{k+1} can be in phase 2. It follows that $x = \dot{s}_k t$ is either a 1,2- or a 3,2-phase boundary. According to (4.6), the driving traction at this phase boundary must be positive in either case, whence by the admissibility requirement (5.5), necessarily $\dot{s}_k \geq 0$. Similarly, the phase boundary $x = \dot{s}_{k+1} t$ must be either of 2,1- or 2,3-type, so that by (4.6), (5.5), one has $\dot{s}_{k+1} \leq 0$. Thus $\dot{s}_k \geq \dot{s}_{k+1}$, contradicting (5.3). It follows that no phase-2 strain γ_k can emerge from metastable initial data; this is a consequence of the fact that admissibility prevents an increase in length of any portion of the bar that bears a phase-2 strain and is terminated at both ends by phase boundaries.

Turning to (ii), we note first that the assertion is trivially true if $N \leq 2$, so we may assume that $N \geq 3$. We first show that if $x = \dot{s}_k t$ and $x = \dot{s}_{k+1} t$, $k = 1, \dots, N - 1$, are adjacent subsonic phase boundaries in the representation (5.2), then necessarily

$$\dot{s}_k \leq 0 \leq \dot{s}_{k+1}. \quad (6.1)$$

To prove (6.1), we begin by inferring from the result in (i) that either (a) $x = \dot{s}_k t$ is a 3,1-phase boundary while $x = \dot{s}_{k+1} t$ is of 1,3-type, or (b) the reverse is true. Suppose (a) is the case. Then by (4.7) and (4.9), we have

$$\gamma_k = \frac{1}{\beta(\dot{s}_k)} \gamma_{k-1}, \quad \gamma_{k+1} = \beta(\dot{s}_{k+1}) \gamma_k = \frac{\beta(\dot{s}_{k+1})}{\beta(\dot{s}_k)} \gamma_{k-1}, \quad (6.2)$$

where β is defined in (4.8). The driving tractions f_k and f_{k+1} acting on the two phase boundaries can be calculated from (4.5) and (4.4), respectively; using these in the admissibility conditions (5.5) for $j = k$ and $j = k + 1$ leads immediately to the inequalities

$$g_k \dot{s}_k \leq 0, \quad g_{k+1} \dot{s}_{k+1} \geq 0, \quad (6.3)$$

where

$$g_k = \gamma_M \gamma_m - \gamma_{k-1} \gamma_k, \quad g_{k+1} = \gamma_M \gamma_m - \gamma_k \gamma_{k+1}. \quad (6.4)$$

Suppose that $\dot{s}_k > 0$. Then by (5.3), $\dot{s}_{k+1} > 0$ as well, so that (6.3) gives $g_k \leq 0$, $g_{k+1} \geq 0$, hence

$$g_{k+1} - g_k \geq 0. \quad (6.5)$$

By (6.4) and (6.2),

$$g_{k+1} - g_k = \frac{\gamma_{k-1}^2}{\beta^2(\dot{s}_k)} [\beta(\dot{s}_k) - \beta(\dot{s}_{k+1})]; \quad (6.6)$$

from (6.5) and (6.6), it follows that $\beta(\dot{s}_k) \geq \beta(\dot{s}_{k+1})$. On the other hand, since \dot{s}_k and \dot{s}_{k+1} are both positive and subsonic, the definition (4.8) yields $\beta(\dot{s}_k) < \beta(\dot{s}_{k+1})$. This contradiction shows that $\dot{s}_k \leq 0$. Next, if one assumes that $\dot{s}_{k+1} < 0$, an argument similar to that given above leads again to a contradiction, establishing the result (6.1) in case (a). Case (b), in which phases 3 and 1 are interchanged, is treated by a similar argument. This establishes (6.1).

It then follows that for *no* value of j among the integers $0, \dots, N - 1$ can it be that either $\dot{s}_j < \dot{s}_{j+1} < 0$ or $0 < \dot{s}_j < \dot{s}_{j+1}$ when $x = \dot{s}_j t$ and $x = \dot{s}_{j+1} t$ are subsonic phase boundaries. Thus there are two possibilities: Either there are exactly two subsonic phase boundaries $x = \dot{s}_k t$ and $x = \dot{s}_{k+1} t$, with $\dot{s}_k \leq 0$, $\dot{s}_{k+1} \geq 0$, $\dot{s}_k < \dot{s}_{k+1}$, or there are three, with velocities \dot{s}_k , \dot{s}_{k+1} and \dot{s}_{k+2} such that

$$\dot{s}_k < \dot{s}_{k+1} = 0 < \dot{s}_{k+2}. \quad (6.7)$$

In order to complete the proof of proposition (ii), we need only show that the second possibility cannot occur. Suppose the contrary, so that there are three subsonic phase boundaries whose velocities satisfy (6.7). Note from (6.7), (4.8) that $\beta(\dot{s}_k) > \beta(\dot{s}_{k+1}) > 0$ and $\beta(\dot{s}_{k+2}) > \beta(\dot{s}_{k+1}) > 0$, whence

$$\beta(\dot{s}_k) \beta(\dot{s}_{k+2}) > \beta^2(\dot{s}_{k+1}). \quad (6.8)$$

Again, there are two cases: either (a) $x = \dot{s}_k t$, $x = \dot{s}_{k+1} t = 0$ and $x = \dot{s}_{k+2} t$ are phase boundaries of type 1,3, type 3,1 and type 1,3, respectively, or (b), they are of type 3,1, type 1,3 and type 3,1, respectively. In either of these two cases, the

admissibility conditions (5.5) applied to the two moving phase boundaries $x = \dot{s}_k t$ and $x = \dot{s}_{k+2} t$ can be shown to require that $\beta(\dot{s}_k) \beta(\dot{s}_{k+2}) \leq \beta^2(\dot{s}_{k+1})$, contradicting (6.8) and ruling out the occurrence of three subsonic phase boundaries. Proposition (ii) is therefore established.

To prove proposition (iii), we first note that, according to proposition (i), each phase boundary is either of 3,1-type or of 1,3-type, so that, according to Table 2, the velocity of a supersonically moving phase boundary must lie in one of the two intervals $[c', c_*)$, $(-c_*, -c']$. Suppose there were two or more supersonic phase boundaries with velocities in $[c', c_*)$, and let $x = \dot{s}_k t$ and $x = \dot{s}_{k+1} t$ be two adjacent ones. By Table 2, each of these must be of 1,3-type, which is impossible. Similarly, there cannot be two or more phase boundary velocities in the interval $(-c_*, -c']$. Thus at most two supersonic phase boundaries can occur; if there are two, one moves with velocity in $[c', c_*)$, the other with velocity in $(-c_*, -c']$, establishing proposition (iii).

Finally, we take up proposition (iv). Suppose that (γ, v) involves both subsonic and supersonic phase boundaries. Then there are phase boundary velocities \dot{s}_i and \dot{s}_k such that $\dot{s}_i \in (-c', c')$ and either $\dot{s}_k \in [c', c_*)$ or $\dot{s}_k \in (-c_*, -c']$. Suppose first that $\dot{s}_k \in [c', c_*)$; assume that i corresponds to the subsonic phase boundary with greatest velocity, k to the supersonic phase boundary, so that there can be no other phase boundaries between $x = \dot{s}_i t$ and $x = \dot{s}_k t$. By Table 2, the supersonic phase boundary must be of 1,3-type. The subsonic boundary $x = \dot{s}_i t$ must therefore be of 3,1-type. (No shock wave could intervene between these two phase boundaries, because it would have to be a 1,1-shock, whose velocity $\pm c$ could not lie between \dot{s}_i and \dot{s}_k .) According to Figure 8, the phase-1 strain between the two phase boundaries must be negative if $x = \dot{s}_k t$ is to be supersonic. But it can be readily shown that this is inconsistent with the assumption that the 3,1-phase boundary at $x = \dot{s}_i t$ is subsonic. This contradiction rules out $\dot{s}_i \in (-c', c')$, $\dot{s}_k \in [c', c_*)$; the possibility that $\dot{s}_k \in (-c_*, -c']$ is ruled out by a similar argument. Proposition (iv) is thus proved.

The arguments used to establish the four results above depend critically on the admissibility inequalities (5.5), which in turn are consequences of the second law of thermodynamics, if the processes under consideration here are viewed as taking place isothermally.

7. Explicit solutions

The qualitative results established in the preceding section make it possible to construct explicitly all admissible solutions to the Riemann problem for the trilinear material in the case of metastable initial data. We say the initial data is of p, q -type if γ_L is in phase p , γ_R in phase q , and we speak of a p, q -Riemann problem. For metastable initial data, there are four cases of the Riemann problem: Initial data are either of 1,3-type, 3,1-type, 1,1-type or 3,3-type. In the first two cases, the initial data involve two distinct phases, while in the last two, the initial data are associated with a single phase. By symmetry, the second case need not be considered once the first case has been treated. We begin with the case of 1,3-initial data.

(i) *The Riemann problem for 1,3-initial data*

For such data, one has $\gamma_L \in (-1, \gamma_M]$, $\gamma_R \in [\gamma_m, \infty)$. In view of proposition (i) of the preceding section, the solution γ, v must involve an odd number of phase boundaries. However, by results (ii)–(iv) of that section, no more than two phase boundaries can occur. Thus precisely one phase boundary is involved, and it may be either subsonic or supersonic. We begin with the subsonic case.

(i(a)) *1-3 initial data: solutions with one subsonic phase boundary.* In (5.2), we take $N = 3$, with $\dot{s}_1 = -c$, $\dot{s}_2 = \dot{s}$, $\dot{s}_3 = +c'$, where $-c' < \dot{s} < c'$; this allows for one subsonic phase boundary $x = \dot{s}t$ and two shock waves, the left one at $x = -ct$ of 1,1-type, the right one at $x = c't$ of 3,3-type. Thus we have see (Figure 11(a)):

$$\gamma, v = \begin{cases} \gamma_L, v_L, & -\infty < x < -ct, \\ \bar{\gamma}, \bar{v}, & -ct < x < \dot{s}t, \\ \overset{+}{\gamma}, \overset{+}{v}, & \dot{s}t < x < c't \\ \gamma_R, v_R, & c' < x < +\infty \end{cases} \tag{7.1}$$

where $\bar{\gamma}, \bar{v}, \overset{+}{\gamma}, \overset{+}{v}$ and \dot{s} are unknowns, with

$$0 < \bar{\gamma} \leq \gamma_M, \quad \overset{+}{\gamma} \geq \gamma_m, \quad -c' < \dot{s} < c'. \tag{7.2}$$

(The fact that $\bar{\gamma} > 0$ follows from Figure 8 and the assumption that $|\dot{s}| < c'$.) The five unknowns are to be found from the jump conditions (5.4), which under

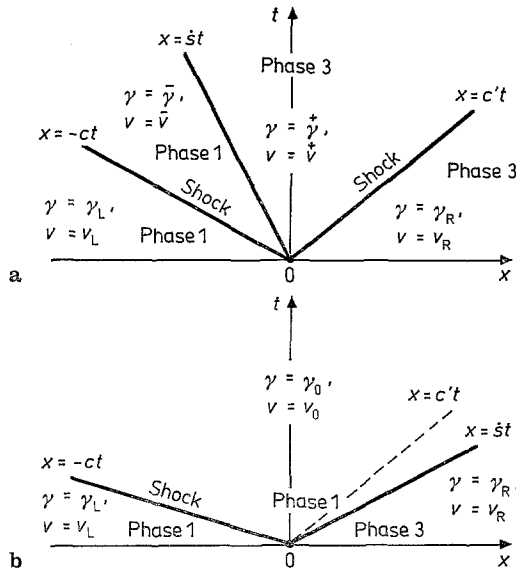

Fig. 11. Form of solutions to Riemann problem with 1,3-initial data. (a) Subsonic phase boundary, (b) Supersonic phase boundary

the present circumstances reduce to

$$-c(\bar{\gamma} - \gamma_L) = -(\bar{v} - v_L), \quad (7.3)$$

$$\dot{s}(\bar{\gamma}^+ - \bar{\gamma}) = -(\bar{v}^+ - \bar{v}), \quad (7.4)$$

$$c'^2 \bar{\gamma}^+ - c^2 \bar{\gamma} = -\dot{s}(\bar{v}^+ - \bar{v}), \quad (7.5)$$

$$c'(\gamma_R - \bar{\gamma}^+) = -(v_R - \bar{v}^+). \quad (7.6)$$

These comprise four equations for the five unknowns, suggesting a one-parameter family of solutions. Indeed, solving (7.3)–(7.6) for $\bar{\gamma}^+$, \bar{v}^+ , $\bar{\gamma}$ and \bar{v} in terms of \dot{s} gives

$$\begin{aligned} \bar{\gamma} &= \frac{c' + \dot{s}}{c + \dot{s}} h, & \bar{\gamma}^+ &= \frac{c - \dot{s}}{c' - \dot{s}} h, \\ \bar{v} &= v_L - c\gamma_L + \frac{c' + \dot{s}}{c + \dot{s}} ch, & \bar{v}^+ &= v_R + c'\gamma_R - \frac{c - \dot{s}}{c' - \dot{s}} c'h, \end{aligned} \quad (7.7)$$

where

$$h = (c\gamma_L + c'\gamma_R + v_R - v_L)/(c + c'). \quad (7.8)$$

Note that h depends only on the material and the given data, and that the strains $\bar{\gamma}^+$ and $\bar{\gamma}$ depend on the initial data *only* through h . By (7.2), (7.7), the inequalities

$$0 < \frac{c' + \dot{s}}{c + \dot{s}} h \leq \gamma_M, \quad \frac{c - \dot{s}}{c' - \dot{s}} h \geq \gamma_m, \quad -c' < \dot{s} < c', \quad (7.9)$$

must hold. One shows easily that the leftmost inequality in (7.9) holds automatically if the remaining inequalities are satisfied. It also follows that the initial data must necessarily be such that

$$h > 0. \quad (7.10)$$

Thus altogether, h and \dot{s} must satisfy

$$\gamma_m \frac{c' - \dot{s}}{c - \dot{s}} \leq h \leq \gamma_M \frac{c + \dot{s}}{c' + \dot{s}}, \quad -c' < \dot{s} < c'. \quad (7.11)$$

In the s, h -plane of Figure 12, the inequalities (7.11) describe the region on and between the top and bottom curves C_1 and C_2 . The respective equations for C_1 and C_2 are $h = \gamma_M(c + \dot{s})/(c' + \dot{s})$ and $h = \gamma_m(c' - \dot{s})/(c - \dot{s})$, $-c' < \dot{s} < c'$.

Let 1,3-initial data be given such that h in (7.8) is positive. For any such h , Figure 12 shows that there is a range of \dot{s} (a subinterval of $(-c', c')$) in which (7.11) hold. For each \dot{s} in this range and for the given h , define $\bar{\gamma}^+$, $\bar{\gamma}$, \bar{v}^+ and \bar{v} by (7.7), γ and v by (7.1). Then (7.2) are satisfied, and the set of all pairs γ, v so constructed comprises a 1-parameter family (parameter \dot{s}) of solutions to the Riemann problem for the given h ; in each solution there is a subsonically moving phase boundary. The condition (7.10) on the initial data is therefore necessary and

sufficient for the existence of solutions of the form (7.1) with a subsonic 1,3-phase boundary in the case of 1,3-initial data. We now determine which of these solutions, if any, are admissible.

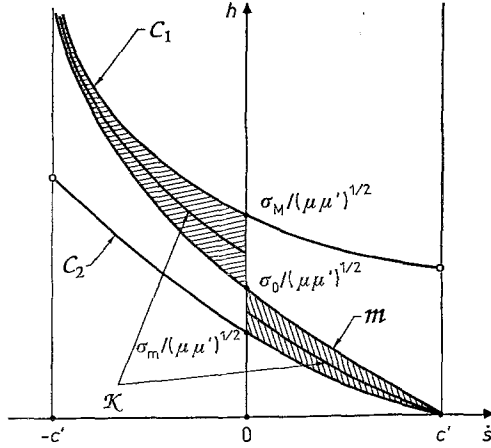

Fig. 12. The \dot{s} , h -plane for 1,3-initial data

Since the phase boundary in the solutions constructed above is of 1,3-type, the associated driving traction f is given by (4.4), with $\bar{\gamma}, \gamma^+$ given by (7.7)_{1,2}; thus

$$f = \frac{1}{2}(\mu - \mu') \left\{ \gamma_m \gamma_M - \frac{(c' + \dot{s})(c - \dot{s})}{(c' - \dot{s})(c + \dot{s})} h^2 \right\}. \tag{7.12}$$

With this f , the admissibility condition (5.5) leads to the requirement

$$\left\{ \gamma_m \gamma_M - \frac{(c' + \dot{s})(c - \dot{s})}{(c' - \dot{s})(c + \dot{s})} h^2 \right\} \dot{s} \geq 0. \tag{7.13}$$

Inequality (7.13) reduces the set of solutions to that corresponding to the hatched regions in Figure 12; the “Maxwell curve” M shown in the figure is the curve along which the contents of the braces in (7.12) vanish, and thus on which $f = 0$. All points in the hatched region correspond to *admissible* solutions of the present Riemann problem. As expected, the entropy condition for admissibility (5.5) does *not* deliver uniqueness. Indeed, Figure 12 shows that, for every positive value of h except $h = \sigma_0/(\mu\mu')^{1/2}$, there is a 1-parameter family (parameter \dot{s}) of admissible solutions of the Riemann problem. For the exceptional value of h , there is a *unique* admissible solution; it has a *stationary* 1,3-phase boundary ($\dot{s} = 0$) with zero driving traction. This solution tends for large time to an equilibrium mixture of phases 1 and 3 at the Maxwell stress. All other values of the initial datum h in the interval $[\sigma_m/(\mu\mu')^{1/2}, \sigma_M/(\mu\mu')^{1/2}]$ correspond to solutions that give rise either to long-time mixed-phase equilibria corresponding to $\dot{s} = 0$ or to single-phase equilibria ($\dot{s} \neq 0$); the mixed-phase equilibria are not Maxwell states, and hence are metastable. For values of h outside this interval, the corre-

sponding long-time equilibrium states involve only a single phase: phase 1 if $0 < h < \sigma_m/(\mu\mu')^{1/2}$, so that $\dot{s} > 0$, phase 3 if $h > \sigma_m/(\mu\mu')^{1/2}$, in which case $\dot{s} < 0$.

For some special values of the initial data, one, or even both, of the shock waves may be absent.

Finally, we shall show that the extent of the lack of uniqueness remaining after the imposition of admissibility is exactly that required for the further imposition of the kinetic relation (3.6) at the phase boundary, and that when the kinetic relation is invoked, it singles out precisely one solution to the Riemann problem presently under consideration. We first use (7.12) to map the \dot{s}, h -plane of Figure 12 into the \dot{s}, f -plane of Figure 9. The hatched regions in Figure 9 are the images in the \dot{s}, f -plane of the hatched regions in the \dot{s}, h -plane corresponding to the totality of admissible solutions. The curves C_1^* and C_2^* are the images of the left half of C_1 and the right half of C_2 , respectively; the \dot{s} -axis in the \dot{s}, f -plane is the image of the Maxwell curve M in the \dot{s}, h -plane. In Figure 9, we have sketched schematically the graph K^* of the kinetic relation $f = \varphi_{13}(\dot{s})$, with \dot{s} restricted to the interval $(-c', c')$. The pre-image K in the \dot{s}, h -plane of K^* is found from (3.6), (7.12) to be described by

$$h = \Phi(\dot{s}) \equiv (\gamma_m \gamma_M)^{1/2} \left\{ \left[1 - \frac{\varphi_{13}(\dot{s})}{f_0} \right] \frac{(c' - \dot{s})(c + \dot{s})}{(c' + \dot{s})(c - \dot{s})} \right\}^{1/2}; \quad (7.14)$$

the curve K is shown in Figure 12. The fact that the kinetic response function $\varphi_{13}(\dot{s})$ is monotonically increasing can be used to show that $\Phi(\dot{s})$ in (7.14) is monotonically decreasing. Also, $\Phi(\dot{s}) \rightarrow +\infty$ as $\dot{s} \rightarrow -c'$, and $\Phi(\dot{s}) \rightarrow 0$ as $\dot{s} \rightarrow c'$. It follows that for any given $h > 0$, (7.14) determines a unique \dot{s} in the interval $(-c', c')$, with the understanding that $\dot{s} = 0$ if the given h lies in the interval $[\Phi(0-), \Phi(0+)]$; see Figure 12. This unique \dot{s} , when used in (7.7), furnishes the unique admissible “subsonic” solution to the 1,3-Riemann problem that is consistent with the kinetic relation $f = \varphi_{13}(\dot{s})$.

Since two distinct phases are present in the initial data, the occurrence of a phase boundary in the solution is inevitable, and no appeal to the initiation criterion is necessary.

(i(b)) *1,3-initial data: solutions with one supersonic phase boundary.* The case of “supersonic” solutions to the 1,3-Riemann problem is quite different. By Table 2, if there is a supersonic 1,3-phase boundary, its velocity must lie in the interval (c', c_*) . Thus in conformity with the results of Section 6, we take $N = 2$ and $\dot{s}_1 = -c$ in (5.2), and we set $\dot{s}_2 = \dot{s}$, with $-c' < \dot{s} < c_*$. This allows for a single supersonic phase boundary at $x = \dot{s}t$ and a shock wave of 1,1-type at $x = -ct$; see Figure 11b. We thus write

$$\gamma, v = \begin{cases} \gamma_L, v_L, & -\infty < x < -ct, \\ \gamma_0, v_0, & -ct < x < \dot{s}t, \\ \gamma_R, v_R, & \dot{s}t < x < +\infty, \end{cases} \quad (7.15)$$

where γ_0, v_0 and \dot{s} are unknowns, subject to $-1 < \gamma_0 < 0$, $c' < \dot{s} < c_*$. (From Figure 8, it can be seen that γ_0 must be negative since the phase boundary is to be supersonic; part of the bar is thus contracted.) It is readily shown that the jump

conditions (5.4) reduce in this case to three equations for the three unknowns. Analysis of these equations shows that they have a solution with γ_0, \dot{s} satisfying the restrictions given above if and only if the 1,3-initial data are such that

$$\frac{1}{c + c'} \{c' \gamma_R - c - [c'^2 \gamma_R^2 + (c^2 + c'^2) \gamma_R + c^2]^{1/2}\} < h < 0, \quad (7.16)$$

where h is defined by (7.8). The leftmost inequality in (7.16) arises from the requirement that γ_0 be greater than -1 , which in turn stems from the requirement that the mapping $x \rightarrow x + u(x, t)$ be invertible at each t . If the initial data satisfy (7.16), then there is a “supersonic” solution of the above form to the 1,3-Riemann problem, and it is unique. Moreover, it can be verified that this solution is automatically admissible. We observe that *there is no possibility of imposing the kinetic relation in the supersonic case of the 1,3-Riemann problem.*

(ii) *The Riemann problem for 1,1-initial data*

If the initial data involve only phase-1 strains, it is clear that a solution of the form (5.2) must involve either no phase boundaries or an even number of them. The results of Section 6 then show that the number of phase boundaries is either zero or two. Moreover, Table 2 can be used to show that if phase boundaries are present, they are necessarily subsonic.

The 1,1-case exhibits a feature not present in the case of the 1,3-Riemann problem just discussed. We shall find that, for certain initial data, there is a solution with *no* phase boundary *as well as* a solution with two phase boundaries satisfying the kinetic relation, making it necessary to invoke an additional constitutive principle to select between these two solutions. Making such a selection is equivalent to specifying when the bar changes phase and when it does not; this is precisely the role of the initiation criterion for the phase 1 \rightarrow phase 3 transformation.

(ii(a)) *1,1-initial data: solutions with no phase boundaries.* Take $N = 2$ in (5.2), and set $\dot{s}_1 = -c, \dot{s}_2 = c$, corresponding to two shock waves of 1,1-type; see Figure 13(a). We thus seek a solution in the form

$$\gamma, v = \begin{cases} \gamma_L, v_L, & -\infty < x < -ct, \\ \gamma_0, v_0, & -ct < x < ct, \\ \gamma_R, v_R, & ct < x < +\infty, \end{cases} \quad (7.17)$$

in which γ_L and γ_R both belong to $(-1, \gamma_M]$, and γ_0, v_0 are the only unknowns. Let

$$h = (c\gamma_L + c\gamma_R + v_R - v_L)/(2c) \quad (7.18)$$

be the 1,1-counterpart of h as defined for the 1,3-case in (7.8). Analysis of the jump conditions (5.4) in this simple case shows immediately that $\gamma_0 = h$, and that *there is a solution of the form (7.17) (i.e., without phase boundaries) to the 1,1-Riemann problem if and only if the 1,1-initial data are such that*

$$-1 < h \leq \sigma_M/\mu; \quad (7.19)$$

moreover, when the datum h lies in this range, there is precisely one such solution. Since this solution involves only shock waves, it is trivially admissible because the material is trilinear; the kinetic relation is of course irrelevant, since no phase boundaries are present.

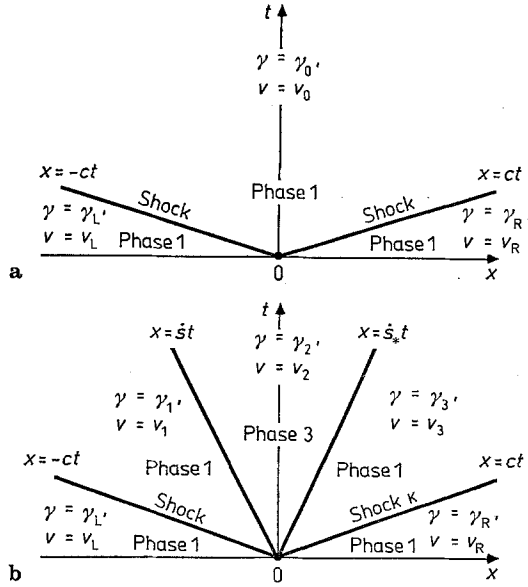

Fig. 13. Form of solutions to Riemann problem with 1,1-initial data. (a) No phase boundaries, (b) Two phase boundaries

(ii(b)) *1,1-initial data: solutions with two phase boundaries.* In view of the results of Section 6, in this case we must take $N = 4$ in (5.2) and set $\dot{s}_1 = -c$, $\dot{s}_2 = \dot{s}$, $\dot{s}_3 = \dot{s}_*$, $\dot{s}_4 = c$, where $-c' < \dot{s} \leq 0 \leq \dot{s}_* < c'$. This corresponds to two shock waves of 1,1-type and two subsonic phase boundaries, one of 1,3-type at $x = \dot{s}t$, another of 3,1-type at $x = \dot{s}_*t$; see Figure 13b. We thus seek a solution in the form

$$\gamma, v = \begin{cases} \gamma_L, v_L, & -\infty < x < -ct, \\ \gamma_1, v_1, & -ct < x < \dot{s}t, \\ \gamma_2, v_2, & \dot{s}t < x < \dot{s}_*t, \\ \gamma_3, v_3, & \dot{s}_*t < x < ct, \\ \gamma_R, v_R, & ct < x < +\infty, \end{cases} \quad (7.20)$$

in which γ_L, γ_R both belong to $(-1, \nu_M]$, and $\gamma_1, v_1, \gamma_2, v_2, \gamma_3, v_3, \dot{s}$ and \dot{s}_* are unknowns.

The jump conditions (5.4) reduce in the present case to six equations for the eight unknowns, and these equations can be readily solved for the strains and particle velocities in terms of the phase boundary speeds \dot{s} and \dot{s}_* ; in particular,

one finds

$$\begin{aligned}\gamma_1 &= 2c \frac{c'^2 - \dot{s}^2}{c^2 - \dot{s}^2} \frac{1}{\Delta(\dot{s}, \dot{s}_*)} h, & \gamma_2 &= 2c \frac{1}{\Delta(\dot{s}, \dot{s}_*)} h, \\ \gamma_3 &= 2c \frac{c'^2 - \dot{s}_*^2}{c^2 - \dot{s}_*^2} \frac{1}{\Delta(\dot{s}, \dot{s}_*)} h,\end{aligned}\quad (7.21)$$

where h is given by (7.18), and

$$\Delta(\dot{s}, \dot{s}_*) \equiv \left[\frac{c'^2 - \dot{s}^2}{c - \dot{s}} + \dot{s}_* - \dot{s} + \frac{c'^2 - \dot{s}_*^2}{c + \dot{s}_*} \right] > 0. \quad (7.22)$$

In order that the strains $\gamma_1, \gamma_2, \gamma_3$ belong to the appropriate phases, one must ensure that

$$-1 < \gamma_1 \leq \gamma_M, \quad \gamma_2 \geq \gamma_m, \quad -1 < \gamma_3 \leq \gamma_M. \quad (7.23)$$

Using an approach parallel to that in sub-section (i(a)), we are able to proceed directly from (7.21) to show that there is a non-empty region in \dot{s}, \dot{s}_*, h -space in which the requirements (7.23) and the admissibility conditions (5.5) are satisfied, so that (for a given h in a suitable range) conditions (7.21), (7.22) provide a 2-parameter family (parameters \dot{s}, \dot{s}_*) of admissible solutions with two phase boundaries to the 1,1-Riemann problem. Imposing the kinetic relations at the two phase boundaries would then lead to a pair of equations to determine \dot{s}, \dot{s}_* and hence a unique solution.

It is more efficient, however, to impose immediately the appropriate kinetic relations at the two phase boundaries. To this end, we first use (4.4), (4.5) and (7.21) to find the driving tractions f and f_* acting on the phase boundaries $x = \dot{s}t$ and $x = \dot{s}_*t$, respectively:

$$\begin{aligned}f &= \frac{1}{2}(\mu - \mu') \left(\gamma_m \gamma_M - \frac{c'^2 - \dot{s}^2}{c^2 - \dot{s}^2} \gamma_2^2 \right), \\ f_* &= -\frac{1}{2}(\mu - \mu') \left(\gamma_m \gamma_M - \frac{c'^2 - \dot{s}_*^2}{c^2 - \dot{s}_*^2} \gamma_2^2 \right),\end{aligned}\quad (7.24)$$

where γ_2 is given by (7.21)₂. The kinetic relations are

$$f = \varphi_{13}(\dot{s}), \quad f_* = \varphi_{31}(\dot{s}_*), \quad (7.25)$$

where φ_{13} and φ_{31} are the kinetic response functions associated with phase boundaries of 1,3-type and 3,1-type, respectively. The analysis is greatly simplified by assuming, as we shall, that the bar is symmetric in the sense that the driving traction acting on a 1,3-phase boundary moving with velocity \dot{s} is the negative of the driving traction acting on a 3,1-phase boundary moving with velocity $-\dot{s}$. Thus the kinetic response functions φ_{13} and φ_{31} are required to satisfy

$$\varphi_{13}(\dot{s}) = -\varphi_{31}(-\dot{s}), \quad -c' < \dot{s} < c'. \quad (7.26)$$

Note that, by (7.26) and Figure 5, $\varphi_{13}(0+) = -\varphi_{31}(0-) = f_M^*$, $\varphi_{13}(0-) = -\varphi_{31}(0+) = f_m^*$.

Eliminating γ_2^2 between the two statements in (7.24) yields

$$(f - f_0) \left(\frac{c^2 - \dot{s}^2}{c'^2 - \dot{s}^2} \right) = -(f_* + f_0) \left(\frac{c^2 - \dot{s}_*^2}{c'^2 - \dot{s}_*^2} \right), \quad (7.27)$$

where $f_0 = (\mu - \mu') \gamma_m \gamma_M / 2 > 0$. Using (7.25) to express f and f_* in (7.27) in terms of φ_{13} and φ_{31} and invoking (7.26) allows us to rewrite (7.27) in the form

$$\theta(\dot{s}) = \theta(-\dot{s}_*), \quad (7.28)$$

where the function θ is defined by

$$\theta(\dot{s}) = [\varphi_{13}(\dot{s}) - f_0] \frac{c^2 - \dot{s}^2}{c'^2 - \dot{s}_*^2}, \quad -c' < \dot{s} \leq 0. \quad (7.29)$$

The fact that φ_{13} is non-positive and strictly increasing on $(-\infty, 0]$ makes it possible to show that θ is strictly increasing on $(-c', 0]$. Since both \dot{s} and $-\dot{s}_*$ lie in $(-c', 0]$, it then follows from (7.28) that

$$\dot{s}_* = -\dot{s}. \quad (7.30)$$

This result allows us to simplify (7.22) and (7.21) to get

$$\gamma_1 = \gamma_3 = \frac{c'^2 - \dot{s}^2}{(c + \dot{s})(c'^2 - c\dot{s})} ch, \quad \gamma_2 = \frac{c - \dot{s}}{(c'^2 - c\dot{s})} ch, \quad -c' < \dot{s} < 0, \quad (7.31)$$

where h is given in terms of initial data by (7.18). Recall from (5.3) that $\dot{s} < \dot{s}_*$, so that, by (7.30), $\dot{s} \neq 0$. Since $\dot{s} < 0 < \dot{s}_*$, all particles of the bar are in phase 3 in the long-time equilibrium state; mixed phase equilibria cannot emerge as long-time limits from pure phase-1 initial states.

In order to complete the solution, we must determine the phase boundary speed \dot{s} from the kinetic relation (7.25)₁, making use of (7.24)₁ and (7.31)₂; it is then only necessary to verify that the strains given by (7.31), evaluated at the appropriate \dot{s} , conform to the requirements (7.23). We begin by noting that, in view of (7.31), the inequalities (7.23) reduce to

$$-1 < \frac{c'^2 - \dot{s}^2}{(c + \dot{s})(c'^2 - c\dot{s})} ch \leq \gamma_M, \quad \frac{c - \dot{s}}{(c'^2 - c\dot{s})} ch \geq \gamma_m. \quad (7.32)$$

The rightmost inequality in (7.32) shows that the initial data must be such that $h > 0$, and if this is the case, the leftmost inequality holds automatically. Indeed, the remaining inequalities to be enforced are

$$\gamma_m \frac{c'^2 - c\dot{s}}{c^2 - c\dot{s}} \leq h \leq \gamma_M \frac{(c + \dot{s})(c'^2 - c\dot{s})}{c(c'^2 - \dot{s}^2)}, \quad -c' < \dot{s} < 0. \quad (7.33)$$

The region in the \dot{s} , h -plane described by (7.33) and shown in Figure 14 lies between the curves G_1 and G_2 and the lines $\dot{s} = -c'$, $\dot{s} = 0$; note that for every $h > \sigma_m/\mu$, there is a non-empty range of \dot{s} such that (7.33) holds. If $\dot{s} \rightarrow 0$ — with h fixed in $[\sigma_m/\mu, \sigma_M/\mu]$, the solution given by (7.20), (7.31) tends to the solu-

tion *without* phase boundaries constructed in subsection (ii(a)). Thus the vertical segment $\dot{s} = 0$, $\sigma_m/\mu \leq h \leq \sigma_M/\mu$ in Figure 14 may be thought of as corresponding to solutions without phase boundaries.

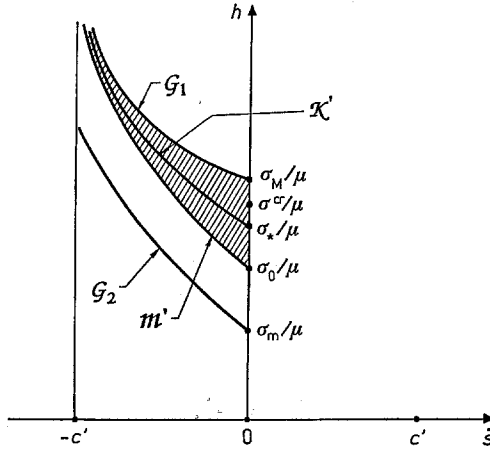

Fig. 14. The \dot{s} , h -plane for 1,1-initial data

If (7.30) and (7.31) are used to compute the driving tractions in (7.24), it is found that

$$f = \frac{1}{2} (\mu - \mu') \left\{ \gamma_m \gamma_M - \frac{(c'^2 - \dot{s}^2)(c - \dot{s})}{(c'^2 - c\dot{s})^2(c + \dot{s})} c^2 h^2 \right\}, \quad f_* = -f. \quad (7.34)$$

Since $\dot{s} < 0$, $\dot{s}_* > 0$, it then follows that the admissibility of both phase boundaries is equivalent to the single inequality $f \leq 0$. Making use of (7.34)₁, we find that the *admissible* subset of the region described by (7.33) is that determined by the following inequalities:

$$\frac{(\gamma_m \gamma_M)^{1/2}}{c} \frac{(c'^2 - c\dot{s})(c + \dot{s})^{1/2}}{[(c'^2 - \dot{s}^2)(c - \dot{s})]^{1/2}} \leq h \leq \gamma_M \frac{(c + \dot{s})(c'^2 - c\dot{s})}{c(c'^2 - \dot{s}^2)}, \quad -c' < \dot{s} < 0; \quad (7.35)$$

this admissible region is shown hatched in Figure 14.

Because of (7.34)₂, (7.30) and (7.26), each of the kinetic relations in (7.25) implies the other, so we need only consider, say, (7.25)₁. We shall now show that (7.25)₁ picks out a unique admissible, two-phase-boundary solution of the 1,1-Riemann problem. As in the discussion of the 1,3-Riemann problem above, we begin by using (7.34)₁ to map the region in the \dot{s} , h -plane characterized by (7.35) and shown in Figure 14 into the \dot{s} , f -plane. It is found that the image of this set under the mapping is exactly the region between the curve C_1^* and the \dot{s} -axis shown in Figure 9. From this, as in the case of the 1,3-Riemann problem, it follows that a kinetic response function $\varphi_{13}(\dot{s})$ appropriate for quasi-static motions remains appropriate in the dynamical case, provided \dot{s} is restricted to the subsonic

range. Finally, we note that when the driving traction is eliminated between (7.25)₁ and (7.34)₁, the result is an equation to determine the value of the parameter \dot{s} in terms of the given h ; this equation may be written in the form

$$h = \Psi(\dot{s}) \equiv (\gamma_m \gamma_M)^{1/2} \frac{1}{c} \left\{ \frac{(c'^2 - c\dot{s})^2 (c + \dot{s})}{(c'^2 - \dot{s}^2) (c - \dot{s})} \left[1 - \frac{\varphi_{13}(\dot{s})}{f_0} \right] \right\}^{1/2}, \quad -c' < \dot{s} < 0. \quad (7.36)$$

The graph of the function Ψ in (7.36) is shown as the curve K' in Figure 14; Ψ is a strictly decreasing function of \dot{s} on $(-c', 0)$, and $\Psi(-c' +) = +\infty$, $\Psi(0-) = \sigma_*/\mu$, where $\sigma_* = \sigma_0(1 - f_m^*/f_0)^{1/2}$. Since $f_m^* \leq 0$, one has $\sigma_0 \leq \sigma_* \leq \sigma_M$. It follows that for all initial data such that

$$h > \sigma_*/\mu, \quad (7.37)$$

the kinetic relation, expressed in the form (7.36), determines a unique velocity $\dot{s} = V(h) < 0$ for the left phase boundary $x = \dot{s}t$.

Thus there is a unique admissible solution to the 1,1-Riemann problem of the form (7.20), with two phase boundaries conforming to the kinetic relations (7.25), if and only if the given 1,1-data are such that

$$\sigma_*/\mu < h < +\infty. \quad (7.38)$$

On the other hand, from the results of subsection (ii(a)), it follows that, when the initial datum h satisfies

$$\sigma_*/\mu < h \leq \sigma_M/\mu, \quad (7.39)$$

the given Riemann problem also has an admissible solution of the form (7.17) with no phase boundaries. Thus for $-1 < h \leq \sigma_*/\mu$, the 1,1-Riemann problem never leads to a phase transformation; for $h > \sigma_M/\mu$, it always does. For the intermediate values of h where both types of solutions exist, a criterion for the initiation of a phase transition is necessary to select the appropriate solution; such a criterion will be discussed below.

(ii(c)) *1,1-initial data: initiation criterion for the phase transformation.* As observed above, when the 1,1-initial data are such that h lies in the interval $(\sigma_*/\mu, \sigma_M/\mu]$, the bar may respond by generating only shock waves at $x = t = 0$, thus remaining entirely in phase 1 for all time, or it may generate a pair of phase boundaries as well as shock waves at $x = t = 0$, in which case the bar ultimately finds itself entirely in phase 3. To determine which of these events occurs, we adapt to the present dynamical setting the initiation criterion discussed for quasi-static phase transformations in Section 3. The particle located at $x = 0$ in the reference state "computes", as it were, the value of h from the given 1,1-initial data in the Riemann problem according to (7.18). If this h is at least as great as the value σ^{ct}/μ defined in (3.8), then the magnitude of the driving traction on either a leftward-moving 1,3- or a rightward-moving 3,1-phase boundary issuing from $x = 0$ would exceed the critical value $|f_m^{ct}|$ for the phase 1 \rightarrow phase 3 transition, as is easily shown. According to our initiation criterion, the particle would then

spontaneously jump from phase 1 to phase 3, generating — in the present problem — the two phase boundaries constructed above. The criterion thus asserts that the bar will respond to 1,1-initial data in the Riemann problem by generating two shock waves but remaining entirely in phase 1 as long as the initial data is such that $-1 < h < \sigma^{cr}/\mu$; this is the solution constructed in subsection (ii(a)). On the other hand, when $h \geq \sigma^{cr}/\mu$, a spontaneous phase transition occurs at $x = 0$, and the two-phase-boundary solution consistent with the kinetic relation is initiated, leading to a long-time equilibrium state in which the bar is entirely in phase 3; this is the solution of subsection (ii(b)).

In his study of the viscosity-capillarity admissibility condition of SLEMROD (1983), SHEARER (1986) considers general materials of the type represented by Figure 1. It is of interest to note that, for a certain class of single-phase initial data he finds that a given Riemann problem has two solutions, each admissible by his criterion, one of which involves a phase transition, while the other does not. Our discussion above would suggest that such a finding manifests the need for a criterion by which the phase transition is to be initiated.

A notable special case of the 1,1-Riemann problem arises when the bar is initially at rest in a *smooth* phase-1 state: Thus $v_L = v_R = 0$, and $\gamma_L = \gamma_R$, with the initial strain in phase 1. By (7.18), $h = \gamma_L = \gamma_R$ in this case. According to the discussion above, if the initial strain is at least as great as σ^{cr}/μ , a phase transition will occur, leading eventually to a pure phase-3 equilibrium state. Thus even an initially smooth, single-phase equilibrium state may break up dynamically into a mixture of phases 1 and 3, ultimately coming to equilibrium in a new phase.

(iii) *The Riemann problem with 3,3-initial data*

In this case, there are three possible scenarios. The first two are analogous to the two alternatives just discussed in the case of 1,1-initial data: Either two shock waves and no phase boundaries occur, leaving the bar entirely in phase 3, or a phase transition occurs at $x = 0$, generating a 3,1-phase boundary moving leftward and a 1,3-phase boundary moving to the right, both subsonic, in addition to shock waves. The details are similar to those in the 1,1-case, so we omit them. In the third possibility here, the solution involves two *supersonic* phase boundaries, unaccompanied by shock waves. As in the supersonic subcase for 1,3-initial data, this solution is uniquely determined by the data when it exists, and no kinetic relation can be imposed. The respective sets of initial data that lead to either of the first two possibilities, on the one hand, or to the third possibility on the other hand, are disjoint.

8. Concluding remarks

In the case of metastable initial data, it has been shown above that, as expected, the Riemann problem for the trilinear material requires more than the “entropy jump condition” of admissibility (2.12) to render solutions unique. We have further shown that, among the many admissible solutions corresponding to the same initial data and involving phase transitions accompanied by subsonically propa-

gating phase boundaries, a kinetic relation controlling the rate at which the transition occurs will pick a unique solution. Under certain conditions, two types of solutions can arise from a given set of initial data, one of which involves a phase transition while the other does not. An initiation criterion for the relevant phase transition is needed to choose between these two types of response; when such a criterion mandates the occurrence of a phase transition, the kinetic relation controls the evolution of the resulting phase boundaries. The fact that the mathematics needs and can accommodate these two supplementary mechanisms, an initiation criterion and a kinetic relation, seems to be qualitatively consistent with the view taken by materials scientists, for whom models of nucleation and of growth of the product phase in the parent phase are an important part of the explanation of the phase transition process.

Kinetic relations of forms other than that used here could of course be studied. In particular, rate equations based on thermal activation models for the kinetics of phase transformations could be investigated; see, for example, Chapter 17 of RALLS, COURTNEY & WULFF (1976).

As we have shown, under certain conditions there are solutions to the Riemann problem with metastable initial data that involve supersonically propagating phase boundaries. For these, a kinetic relation cannot be imposed, since a solution, when it exists, is uniquely determined by the initial data alone.

It would be of interest to make clear the relationship between the present direct approach to the phase transformation problem through kinetic relations and nucleation criteria, and the approaches based on various "admissibility criteria" of the kind proposed, for example, by DAFERMOS (1973) or by SLEMROD (1983).

An attempt to generalize the present analysis from the case of the trilinear material of Figure 2 to any material with a stress-strain curve qualitatively like that of Figure 1 would encounter a number of complications not present in the trilinear material. First, such materials generally give rise to solutions involving "fans" as well as shock waves. Second, shock waves in such materials are in general dissipative, in contrast to the dissipation-free "linear" shock waves arising in the present model. Third, the velocity of shock waves would be *a priori* unknown in the more general case. How many of the qualitative properties of the solutions constructed in the present paper survive for all materials in the class typified by the curve in Figure 1 is as yet unclear.

One can consider the case of a trilinear stress-strain curve in which the slope of the phase-2 branch, while less than the slopes for phases 1 and 3, is nevertheless positive, so that — in contrast to the case treated here — stress is an *increasing* (although still neither convex nor concave) function of strain. For such a material, *equilibrium* mixtures of phases cannot occur, and there is no counterpart of the quasi-static theory sketched in Section 3. In the dynamical setting, however, the situation is different. Analysis of a 1,3-Riemann problem for this kind of material shows that a kinetic relation can again be imposed, and — when invoked — it will pick a unique solution from among infinitely many admissible ones. This suggests that such a material will support *dynamical* mixtures of phases controlled by a given kinetic relation, but such mixtures will tend to single-phase equilibria in the long-time limit.

Acknowledgment. We have had the benefit of comments and questions from Philip Holmes, Richard James, Quing Jiang, James Rice, Phoebus Rosakis, Stewart Silling and Lev Truskinovsky, to whom we express our thanks. The support of the Mechanics Branch of the Office of Naval Research through Contract N00014-87-K-0117 is gratefully acknowledged.

References

- ABEYARATNE, R. (1981) Discontinuous deformation gradients in the finite twisting of an elastic tube, *Journal of Elasticity* **11**, 43–80.
- ABEYARATNE, R. (1983) An admissibility condition for equilibrium shocks in finite elasticity, *Journal of Elasticity* **13**, 175–184.
- ABEYARATNE, R. & KNOWLES, J. K. (1987a) Non-elliptic elastic materials and the modeling of dissipative mechanical behavior: an example, *Journal of Elasticity* **18**, 227–278.
- ABEYARATNE, R. & KNOWLES, J. K. (1987b) Non-elliptic elastic materials and the modeling of elastic-plastic behavior for finite deformation, *Journal of the Mechanics and Physics of Solids* **35**, 343–365.
- ABEYARATNE, R. & KNOWLES, J. K. (1988a) On the dissipative response due to discontinuous strains in bars of unstable elastic material, *International Journal of Solids and Structures* **24**, 1021–1044.
- ABEYARATNE, R. & KNOWLES, J. K. (1988b) Unstable elastic materials and the viscoelastic response of bars in tension, *Journal of Applied Mechanics* **55**, 491–492.
- ABEYARATNE, R. & KNOWLES, J. K. (1990) On the driving traction acting on a surface of discontinuity in a continuum, *Journal of the Mechanics and Physics of Solids* **38**, 345–360.
- BUNSHAK, R. F. & MEHL, R. F. (1952) Time duration of the formation of a martensite plate and the influence of metallurgical variables, *Journal of Metals* **4**, 1042–1042.
- CHRISTIAN, J. W. (1975) *The Theory of Transformations in Metals and Alloys*, Part I, Pergamon, Oxford.
- DAFERMOS, C. M. (1973) The entropy rate admissibility criterion for solutions of hyperbolic conservation laws, *Journal of Differential Equations* **14**, 202–212.
- DAFERMOS, C. M. (1983) Hyperbolic systems of conservation laws, in *Systems of nonlinear partial differential equations* (J. M. BALL, editor), 25–70, D. Riedel, Dordrecht.
- DAFERMOS, C. M. (1989) Admissible wave fans in nonlinear hyperbolic systems, *Archive for Rational Mechanics and Analysis* **106**, 243–260.
- ERICKSEN, J. L. (1975) Equilibrium of bars, *Journal of Elasticity* **5**, 191–201.
- ESHELBY, J. D. (1956) Continuum theory of lattice defects, in *Solid State Physics*, (F. SEITZ & D. TURNBULL, editors), Vol. 3, 79–144, Academic Press, New York.
- ESHELBY, J. D. (1970) Energy relations and the energy-momentum tensor in continuum mechanics, in *Inelastic Behavior of Solids*, M. F. KANNINEN et al., editors, 77–115, McGraw-Hill, New York.
- FINE, M. E. (1964) *Introduction to Phase Transformations in Condensed Systems*, Macmillan, New York.
- GRUJICIC, M., OLSON, G. B. & OWEN, W. S. (1985a) Mobility of martensite interfaces, *Metallurgical Transactions A*, **16 A**, 1713–1722.
- GRUJICIC, M., OLSON, G. B. & OWEN, W. S. (1985b) Mobility of the $\beta_1 - \gamma'_1$ martensitic interface in Cu–Al–Ni: Part I. Experimental measurements, *Metallurgical Transactions A*, **16 A**, 1723–1734.†

- GURTIN, M. E. (1983) Two-phase deformations of elastic solids, *Archive for Rational Mechanics and Analysis* **84**, 1–29.
- HATTORI, H. (1986a) The Riemann problem for a van der Waals fluid with entropy rate admissibility criterion. Isothermal case, *Archive for Rational Mechanics and Analysis* **92**, 247–263.
- HATTORI, H. (1986b) The Riemann problem for a van der Waals fluid with entropy rate admissibility criterion. Nonisothermal case, *Journal of Differential Equations* **65**, 158–174.
- JAMES, R. D. (1979) Co-existent phases in the one-dimensional theory of elastic bars, *Archive for Rational Mechanics and Analysis* **72**, 99–140.
- JAMES, R. D. (1980) The propagation of phase boundaries in elastic bars, *Archive for Rational Mechanical and Analysis* **73**, 125–158.
- JAMES, R. D. (1981) Finite deformation by mechanical twinning, *Archive for Rational Mechanics and Analysis* **77**, 143–176.
- JAMES, R. D. (1986) Displacive phase transformations in solids, *Journal of the Mechanics and Physics of Solids* **34**, 359–394.
- KNOWLES, J. K. (1979) On the dissipation associated with equilibrium shocks in finite elasticity, *Journal of Elasticity* **9**, 131–158.
- KRISHNAN, R. V. & BROWN, L. C. (1973) Pseudo-elasticity and the strain-memory effect in an Ag-45 at. pct. Cd alloy, *Metallurgical Transactions* **4**, 423–429.
- LAX, P. D. (1973) *Hyperbolic systems of conservation laws and the mathematical theory of shock waves*, Regional Conference Series in Applied Mathematics, No. 11, SIAM, Philadelphia.
- OLEINIK, O. A. (1957) On the uniqueness of the generalized solutions of the Cauchy problem for a nonlinear system of equations occurring in mechanics, *Uspekhi Matematicheskii Nauk (N.S.)* **12**, no. 6(78), 169–176 (in Russian).
- PENCE, T. J. (1986) On the emergence and propagation of a phase boundary in an elastic bar with a suddenly applied end-load, *Journal of Elasticity* **16**, 3–42.
- PORTER, D. A. & EASTERLING, K. E. (1981) *Phase Transformations in Metals and Alloys*, van Nostrand Reinhold, New York.
- RALLS, K. M., COURTNEY, T. H. & WULFF, J. (1976) *Introduction to Materials Science and Engineering*, John Wiley & Sons, New York.
- RICE, J. R. (1970) On the structure of stress-strain relations for time-dependent plastic deformation in metals, *Journal of Applied Mechanics* **37**, 728–737.
- RICE, J. R. (1971) Inelastic constitutive relations for solids: An internal variable theory and its application to metal plasticity, *Journal of the Mechanics and Physics of Solids* **19**, 433–455.
- RICE, J. M. (1975) Continuum mechanics and thermodynamics of plasticity in relation to microscale deformation mechanisms, in *Constitutive Equations in Plasticity* (A. S. ARGON, editor), 23–79, MIT Press, Cambridge, Massachusetts.
- SHEARER, M. (1982) The Riemann problem for a class of conservation laws of mixed type, *Journal of Differential Equations* **46**, 426–443.
- SHEARER, M. (1986) Nonuniqueness of admissible solutions of Riemann initial value problems for a system of conservation laws of mixed type, *Archive for Rational Mechanics and Analysis* **93**, 45–59.
- SHEARER, M. (1988) Dynamic phase transitions in a van der Waals gas, *Quarterly of Applied Mathematics* **46**, 631–636.
- ŠILHAVÝ, M. (1988) On the admissibility of shocks and propagating phase boundaries in a van der Waals fluid, in *Material Instabilities in Continuum Mechanics and Related Mathematical Problems* (J. M. BALL, editor), 481–493, Clarendon Press, Oxford.

- SILLING, S. A. (1988) Consequences of the Maxwell relation for anti-plane shear deformations of an elastic solid, *Journal of Elasticity* **19**, 241–284.
- SILLING, S. A. (1989) Phase changes induced by deformation in isothermal elastic crystals, *Journal of the Mechanics and Physics of Solids* **37**, 293–316.
- SLEMROD, M. (1983) Admissibility criteria for propagating phase boundaries in a van der Waals fluid, *Archive for Rational Mechanics and Analysis* **81**, 301–315.
- SLEMROD, M. (1989) A limiting “viscosity” approach to the Riemann problem for materials exhibiting change of phase, *Archive for Rational Mechanics and Analysis* **105**, 327–365.
- TRUSKINOVSKY, L. M. (1985) Structure of an isothermal phase discontinuity, *Soviet Physics Doklady* **30**, 945–948.
- TRUSKINOVSKY, L. M. (1987) Dynamics of non-equilibrium phase boundaries in a heat-conducting non-linearly elastic medium, *Journal of Applied Mathematics and Mechanics (PMM)* **51**, 777–784.

Department of Mechanical Engineering
Massachusetts Institute of Technology
Cambridge, Massachusetts 02139

and

Division of Engineering and Applied Science
California Institute of Technology
Pasadena, California 91125

(Received June 21, 1990)