

Fault Tolerant Control and Trajectory Planning for Quadrotor UAV

Ankit C. Mehta

Dylan Lu

Guided By:

Dr. Youmin Zhang

December 20, 2010

Quadrotor QBall



Communication Hierarchy

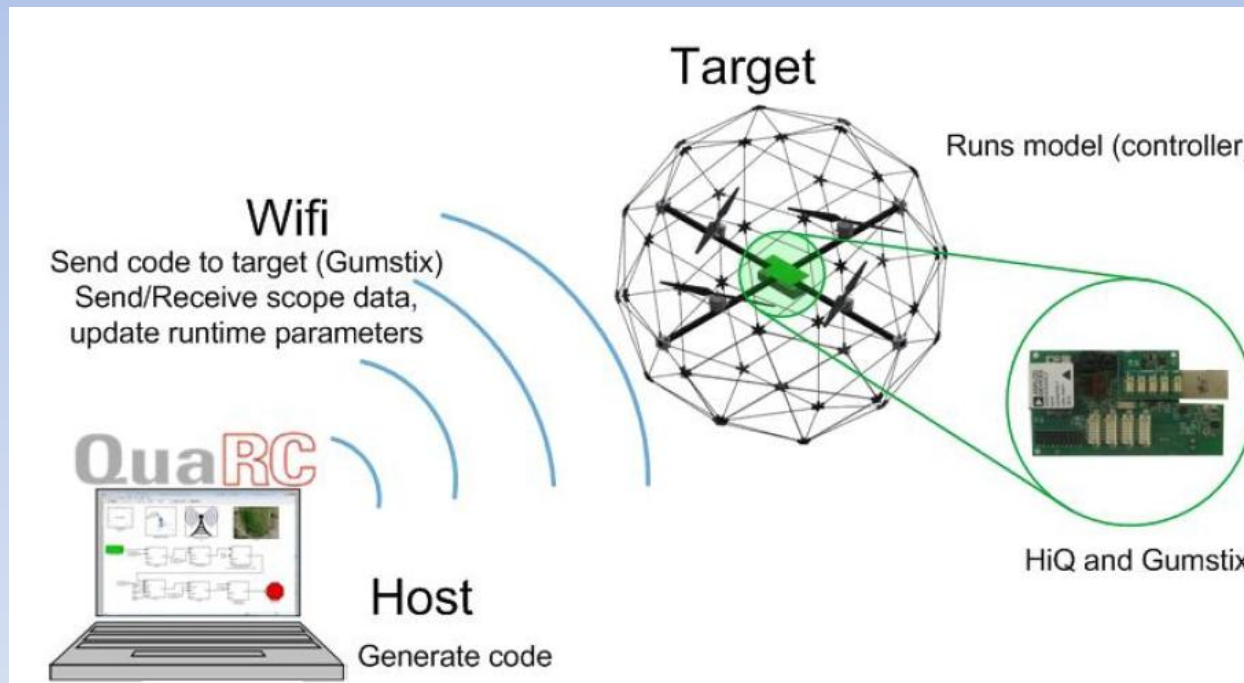

PROPELLERS

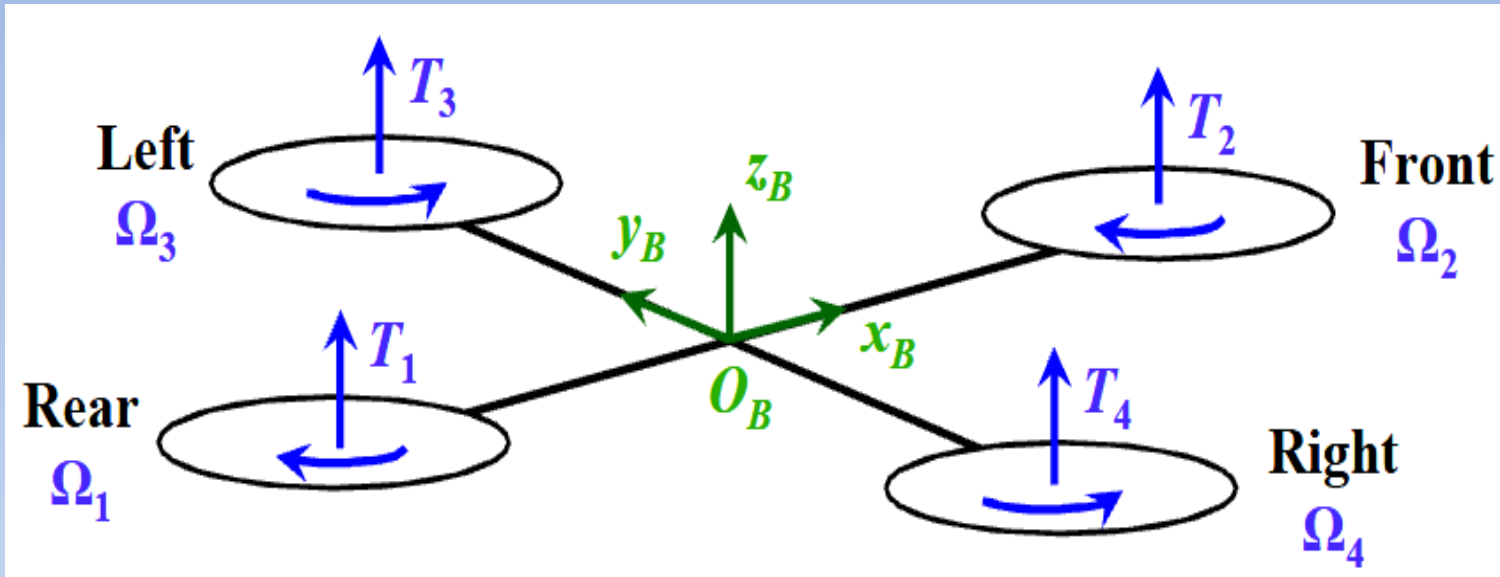

Throttle – All four propellers

Roll – Left & Right

Pitch – Front & Rear

Yaw – Increasing (or decreasing) the front-rear propeller speed and decreasing (or increasing) left-right propeller speed

Height Controller

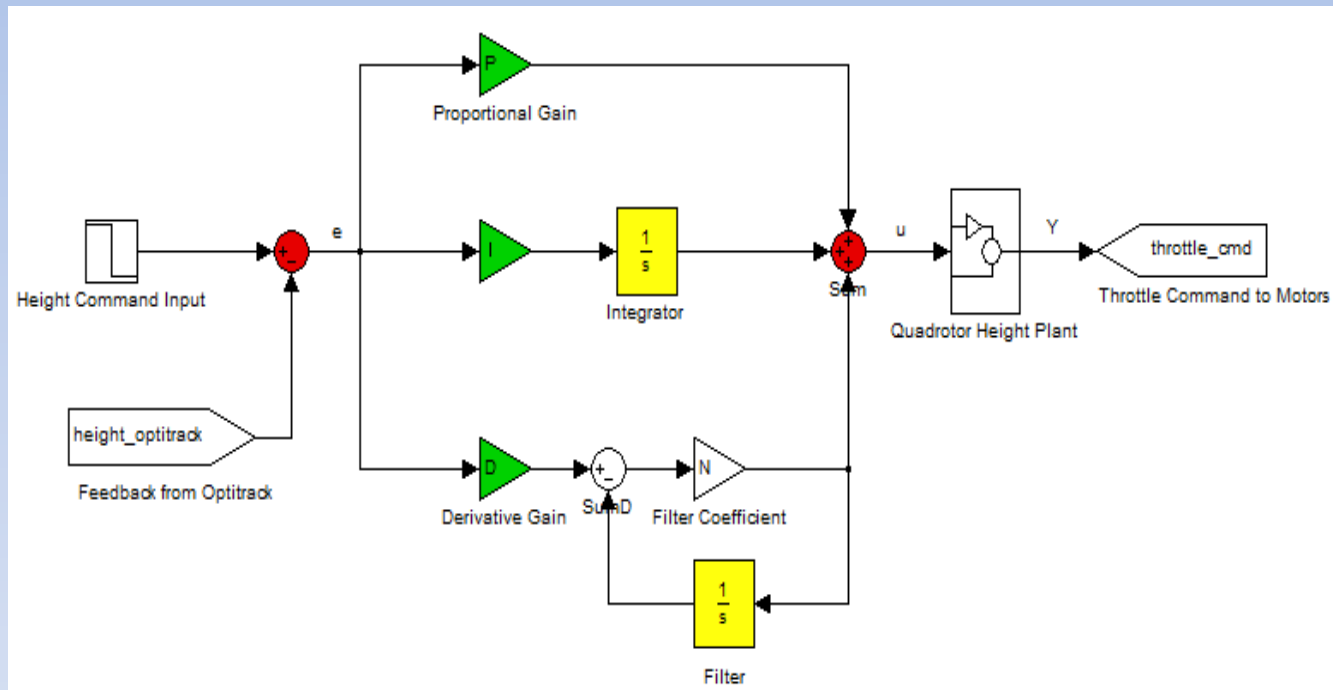

Trajectory

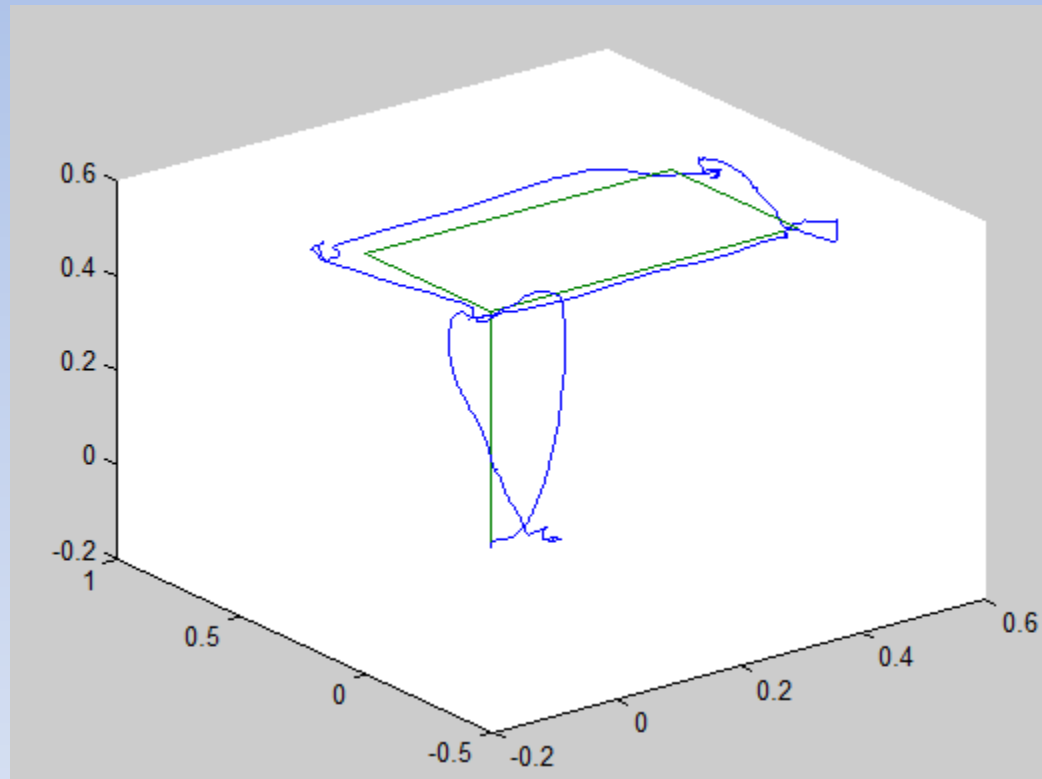

Height Control with fault

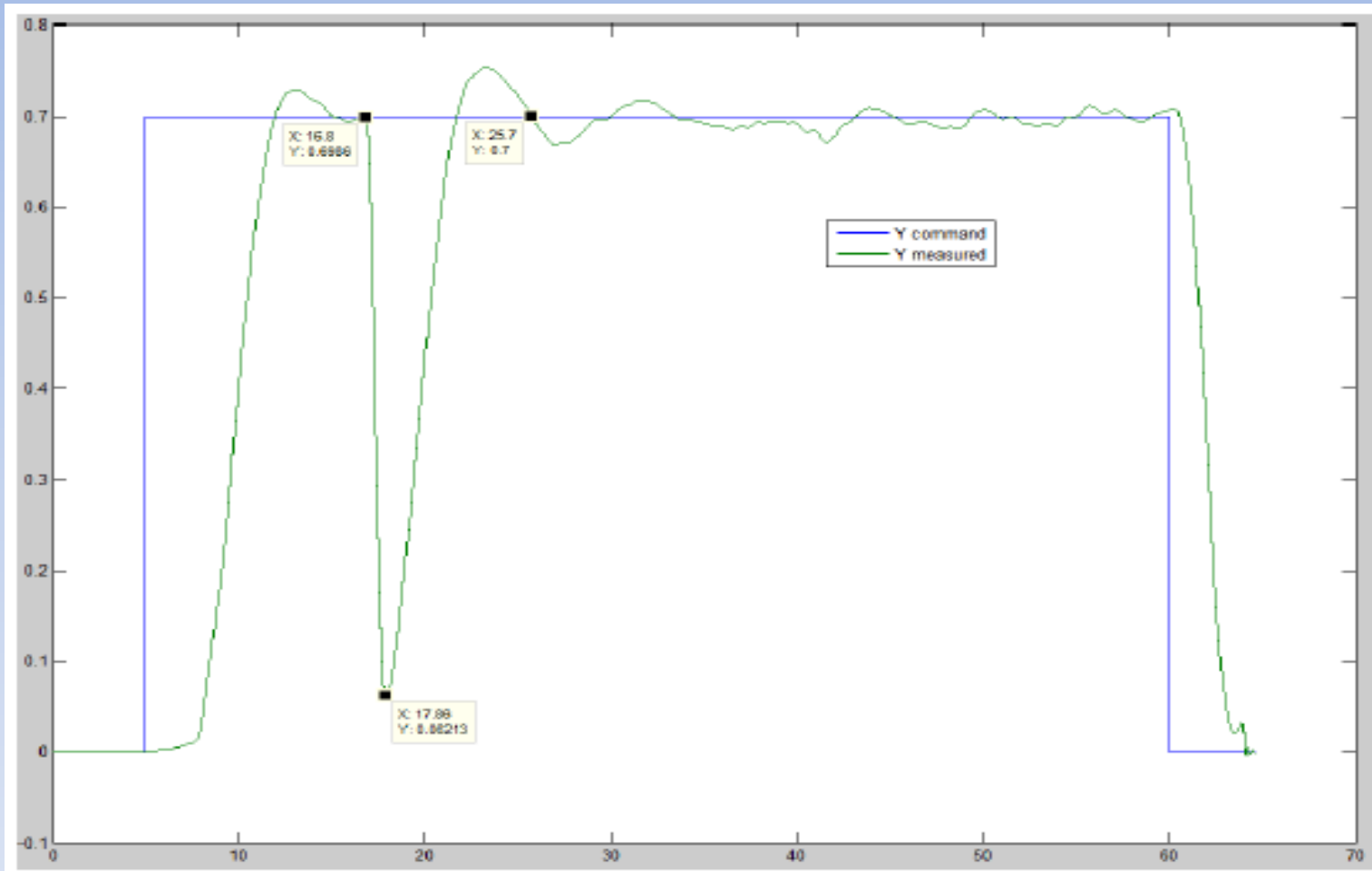

Height Control with fault

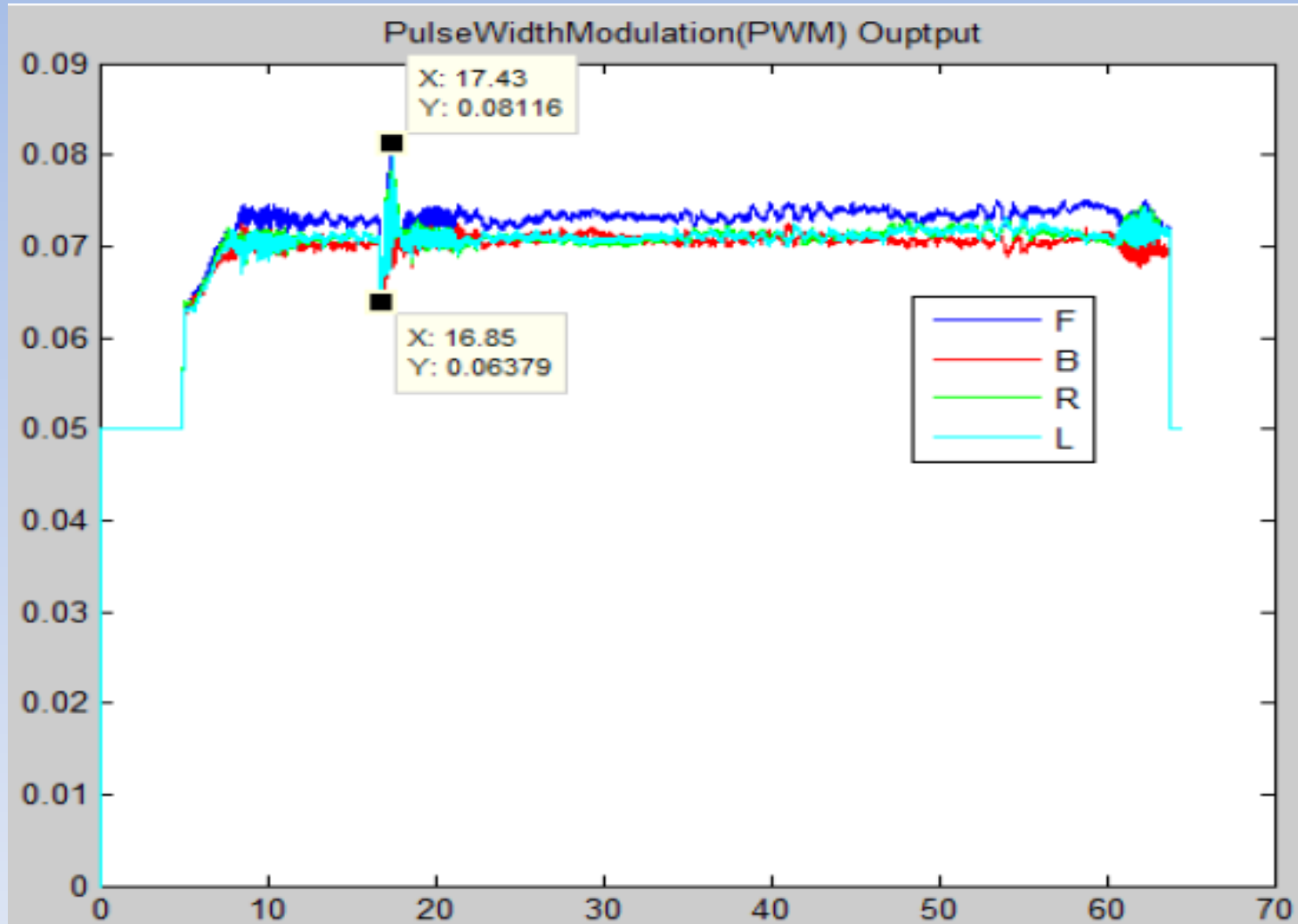

Trajectory Tracking with fault

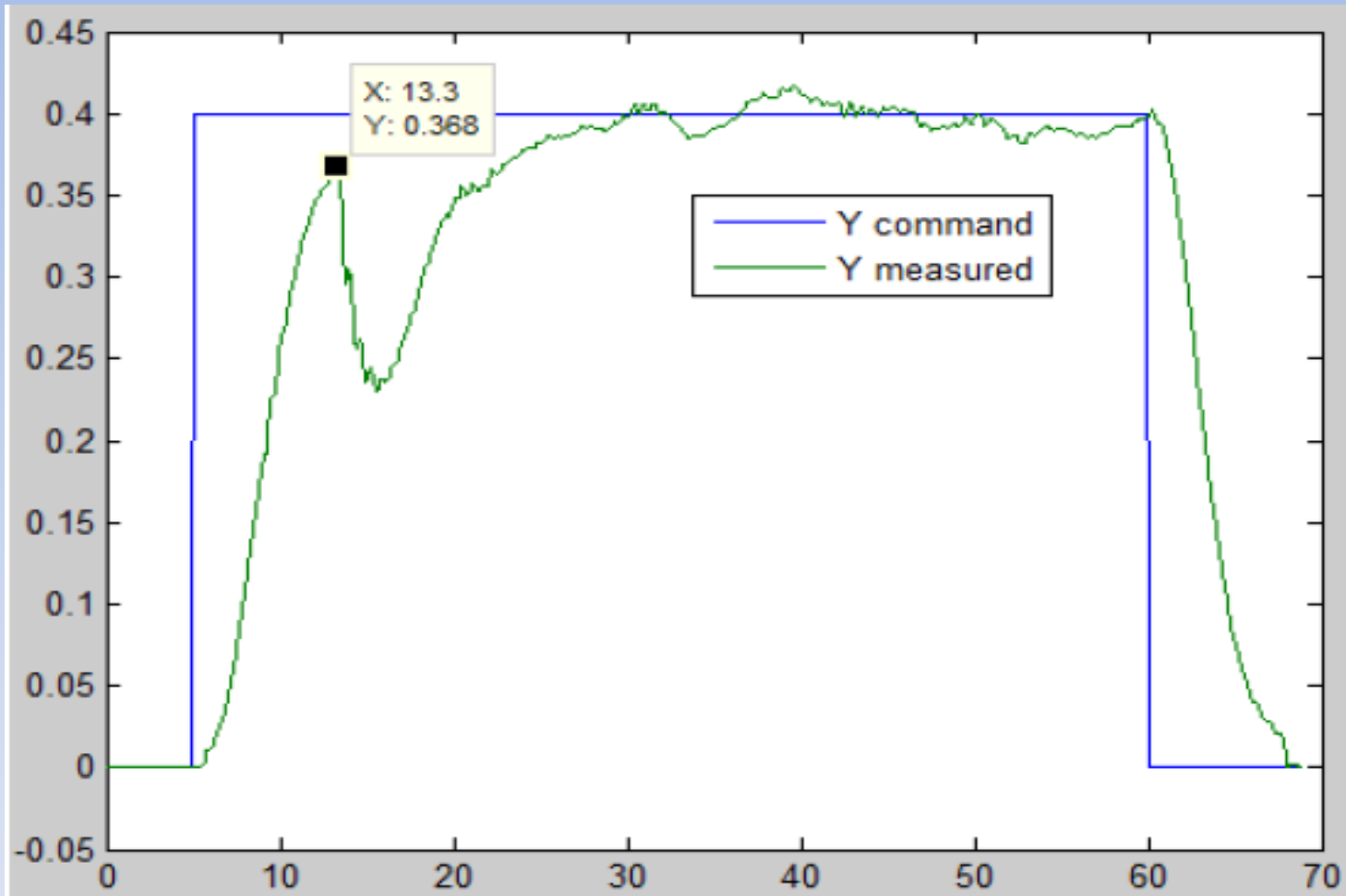

Trajectory Tracking with fault

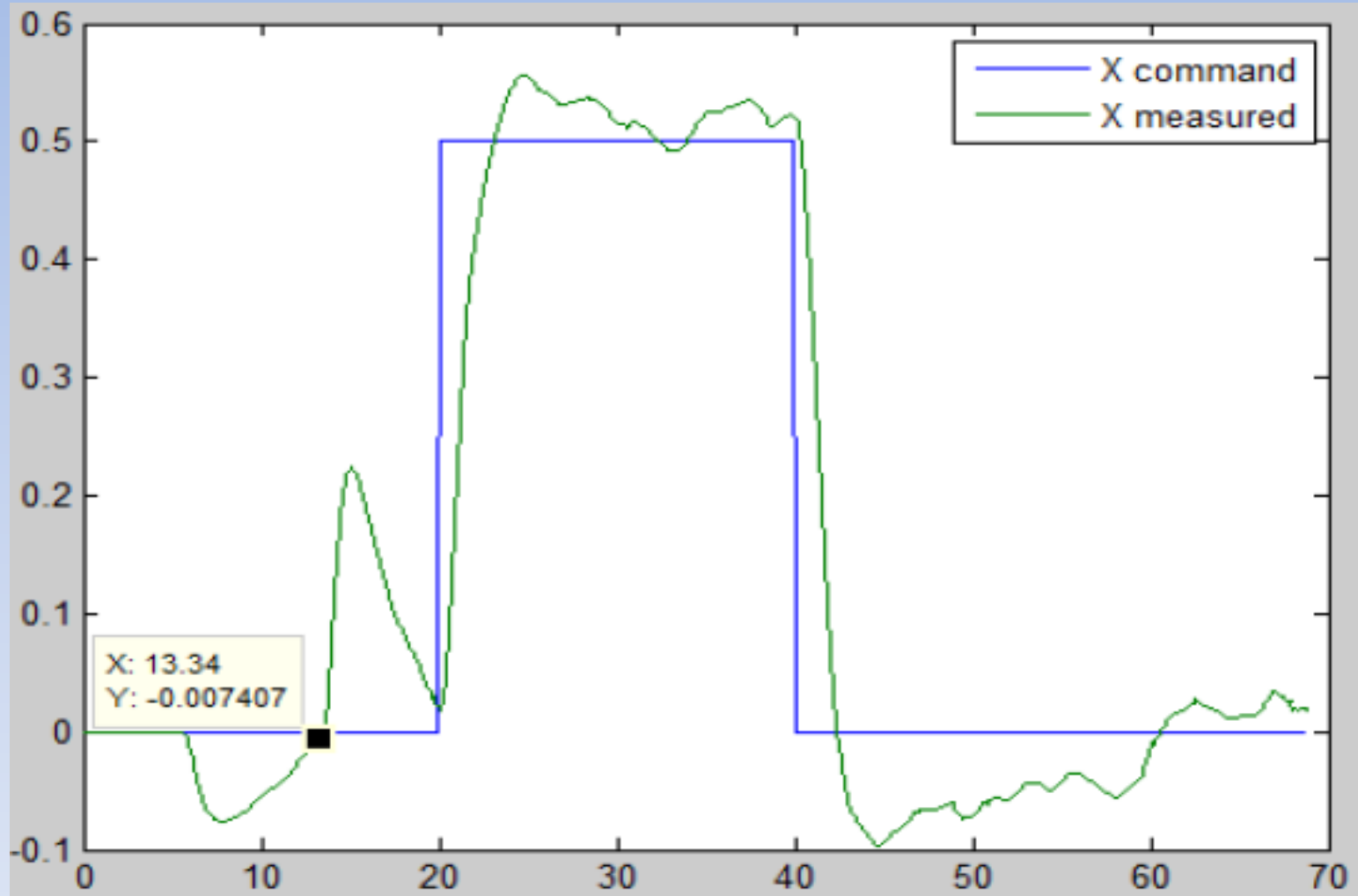

Trajectory Tracking with fault

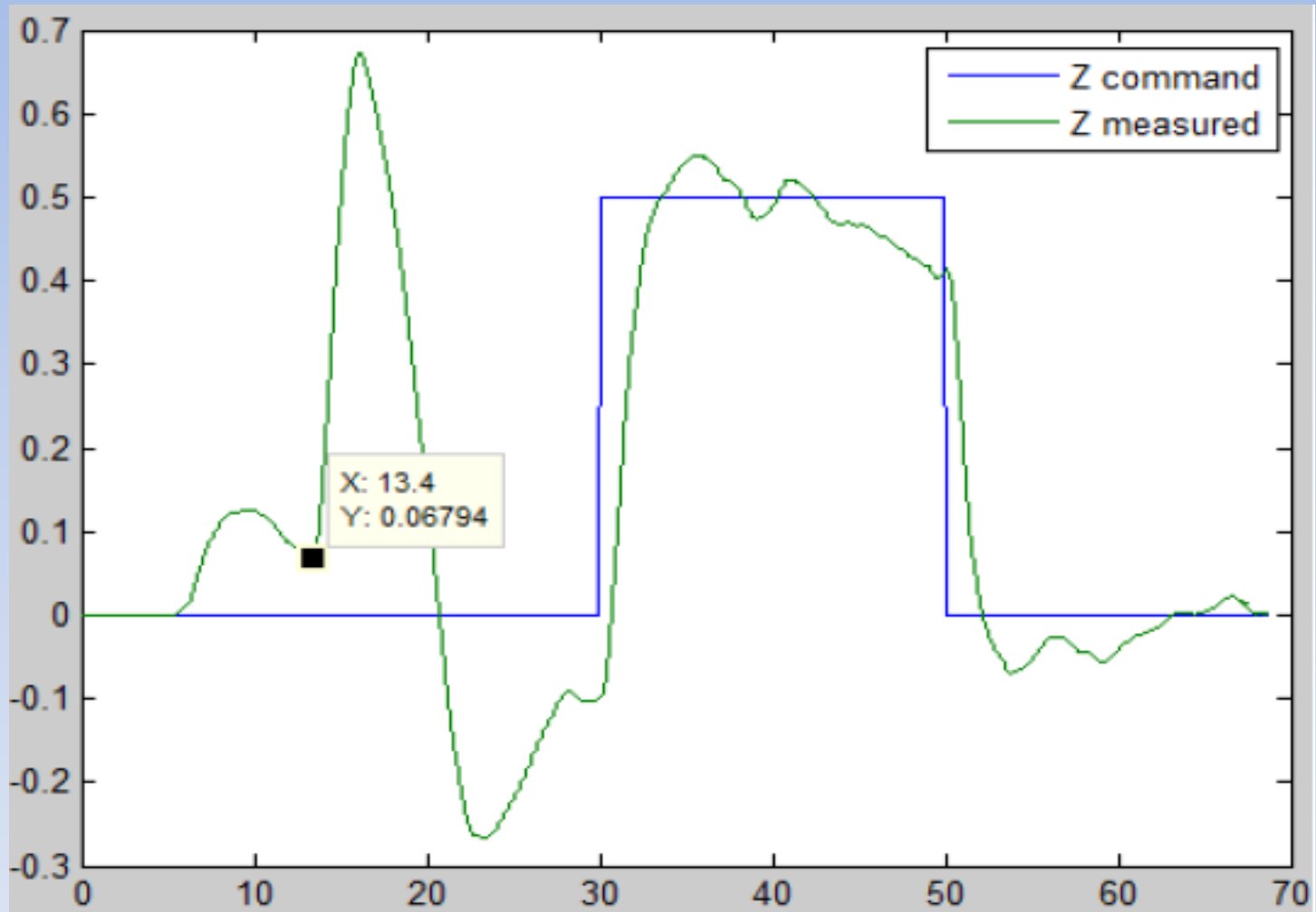

Trajectory Tracking with fault

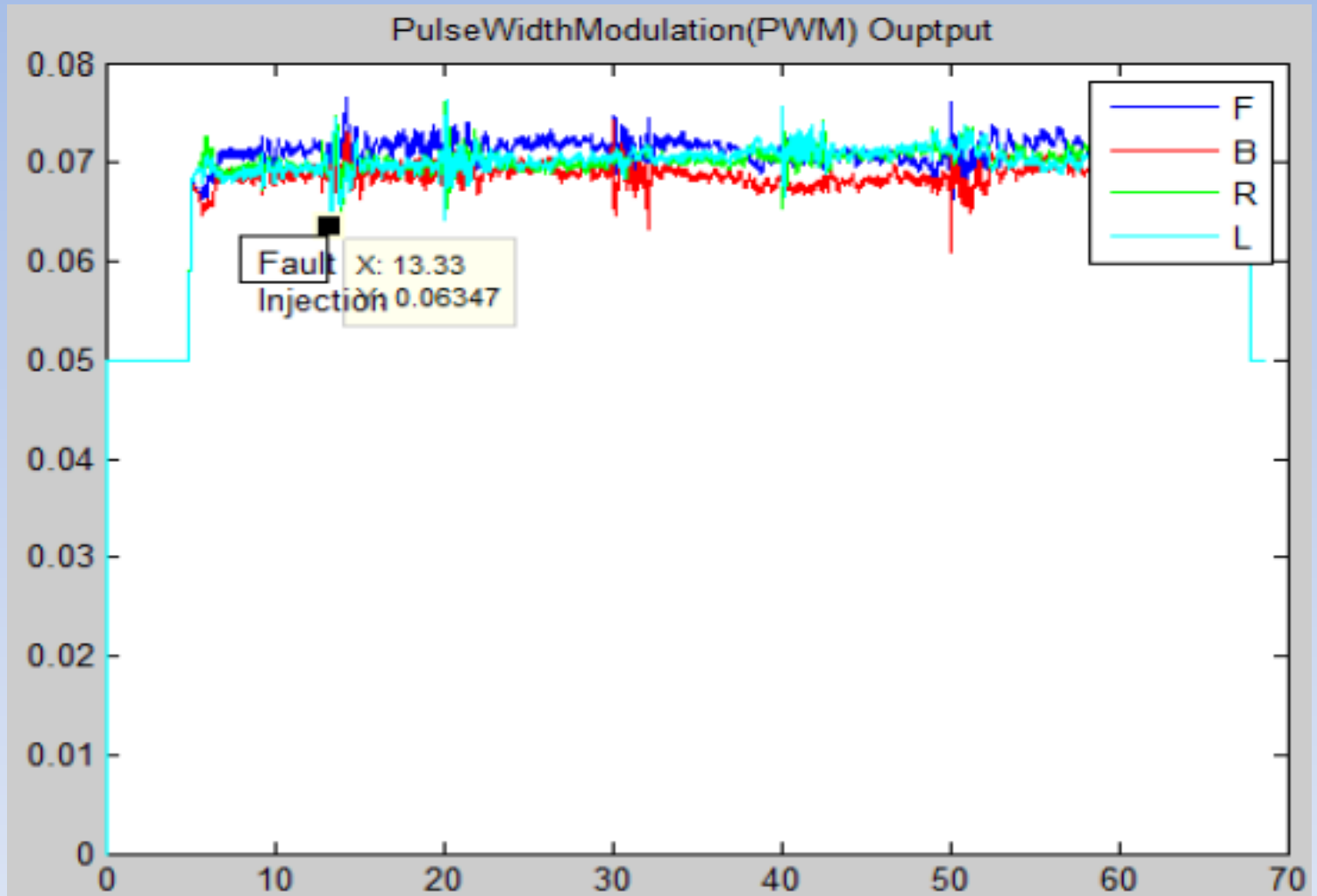

Trajectory Tracking with fault

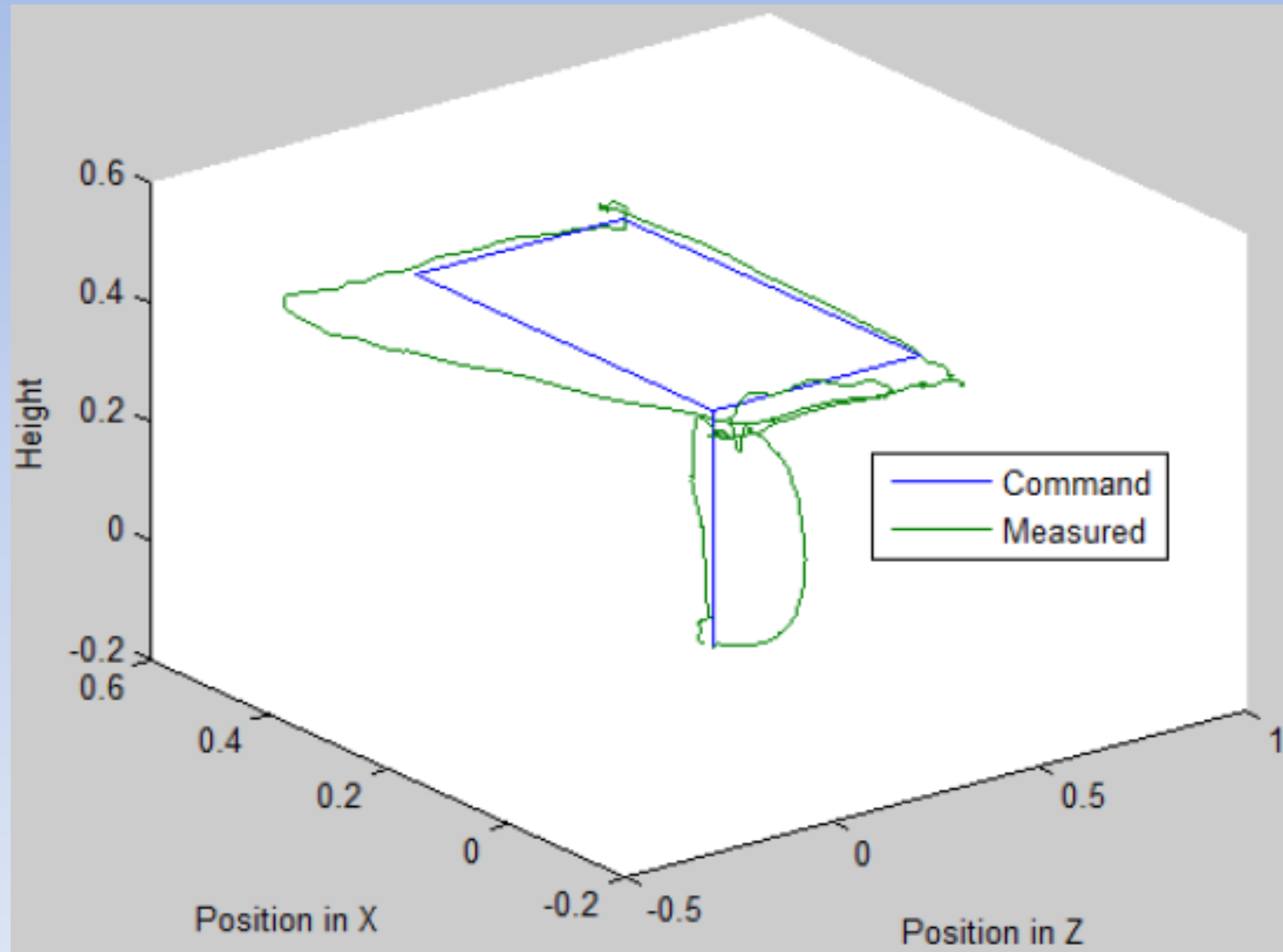



Thank
you



Stockphoto